

## **Trimble® GCS900 Grade Control System for Earthmoving Applications**

Version 12.70  
Revision A  
Part Number 59001-12-ENG  
April 2015



## Contact Information

Trimble Engineering and Construction Division  
5475 Kellenburger Road  
Dayton, Ohio 45424-1099  
USA  
800-538-7800 (toll free in USA)  
+1-937-245-5600 Phone  
+1-937-233-9004 Fax  
www.trimble.com

## Copyright and Trademarks

© 2000–2015 Trimble Navigation Limited and/or its licensors. All rights reserved.  
Trimble, the Globe & Triangle logo, GCSFlex, CCSFlex, and SiteVision are trademarks of Trimble Navigation Limited, registered in the United States and other countries.  
SiteNet, CMR and CMR+ are trademarks of Trimble Navigation Limited. For STL support, the software uses the STLPort adaptation of the Moscow Center for SPARC Technology Standard Template Library. Copyright © 1994 Hewlett-Packard Company, Copyright © 1996, 97 Silicon Graphics Computer Systems, Inc., Copyright © 1997 Moscow Center for SPARC Technology, Copyright © 1999, 2000 Boris Fomitchev. Microsoft, Windows, and Windows NT are trademarks or registered trademarks of Microsoft Corporation in the United States and/or other countries. Wi-Fi, WPA and WPA2 are trademarks of the Wi-Fi Alliance, registered in the United States and other countries. Developed under a License of the European Union and the European Space Agency. Portions of the software are copyright © 2003 Open Design Alliance. SnakeGrid is a registered trademark of UCL Business PLC. The SnakeGrid DLL utilised in the GCS900 Grade Control System software is provided by Trimble under license from UCL Business PLC. Copyright and all other intellectual property rights in the SnakeGrid DLL and any supporting information remains at all times the property of UCL Business PLC and the Licensee shall acquire no rights in any such material except as expressly provided in this Agreement. All rights reserved. All other trademarks are the property of their respective owners.

## Release Notice

This is the April 2015 release (Revision A) of the GCS900 Grade Control System for Earthmoving Applications Reference Manual, part number 59001-12-ENG. It applies to version 12.70 of the GCS900 Grade Control System software.  
The following limited warranties give you specific legal rights. You may have others, which vary from state/jurisdiction to state/jurisdiction.

## Product Warranty Information

For applicable product warranty information, please refer to the warranty documentation included with this product or consult your dealer.

## Notices

Class B Statement – Notice to Users. This equipment has been tested and found to comply with the limits for a Class B digital device, pursuant to Part 15 of the FCC rules. These limits are designed to provide reasonable protection against harmful interference in a residential installation. This equipment generates, uses, and can radiate radio frequency energy and, if not installed and used in accordance with the instructions, may cause harmful interference to radio

communication. However, there is no guarantee that interference will not occur in a particular installation. If this equipment does cause harmful interference to radio or television reception, which can be determined by turning the equipment off and on, the user is encouraged to try to correct the interference by one or more of the following measures:

- Reorient or relocate the receiving antenna.
  - Increase the separation between the equipment and the receiver.
  - Connect the equipment into an outlet on a circuit different from that to which the receiver is connected.
  - Consult the dealer or an experienced radio/TV technician for help.
- Changes and modifications not expressly approved by the manufacturer or registrant of this equipment can void your authority to operate this equipment under Federal Communications Commission rules.

## Canada

This digital apparatus does not exceed the Class B limits for radio noise emissions from digital apparatus as set out in the radio interference regulations of the Canadian Department of Communications.

Le présent appareil numérique n'émet pas de bruits radioélectriques dépassant les limites applicables aux appareils numériques de Classe B prescrites dans le règlement sur le brouillage radioélectrique édicté par le Ministère des Communications du Canada.

## Europe

This product has been tested and found to comply with the requirements for a Class B device pursuant to European Council Directive 89/336/EEC on EMC, thereby satisfying the requirements for CE Marking and sale within the European Economic Area (EEA). Contains Infineon radio module ROK 104001. These requirements are designed to provide reasonable protection against harmful interference when the equipment is operated in a residential or commercial environment.



## Australia and New Zealand

This product conforms with the regulatory requirements of the Australian Communications Authority (ACA) EMC framework, thus satisfying the requirements for C-Tick Marking and sale within Australia and New Zealand.



## Taiwan – Battery Recycling Requirements

The product contains a removable Lithium-ion battery. Taiwanese regulations require that waste batteries are recycled.



## Notice to Our European Union Customers

For product recycling instructions and more information, please go to [www.trimble.com/environment/summary.html](http://www.trimble.com/environment/summary.html).

Recycling in Europe: To recycle Trimble WEEE (Waste Electrical and Electronic Equipment, products that run on electrical power.), Call +31 497 53 24 30, and ask for the "WEEE Associate". Or, mail a request for recycling instructions to:



Trimble Europe BV  
c/o Menlo Worldwide Logistics  
Meerheide 45  
5521 DZ Eersel, NL

## END-USER LICENSE AGREEMENT

IMPORTANT, READ CAREFULLY. THIS END USER LICENSE AGREEMENT ("AGREEMENT") IS A LEGAL AGREEMENT BETWEEN YOU AND CATERPILLAR TRIMBLE CONTROL TECHNOLOGIES LLC ("CTCT") and applies to the computer software provided by CTCT with the GCS, CCS, or PCS series machine control system (the "Product") purchased by you (whether built into hardware circuitry as firmware, embedded in flash memory or a PCMCIA card, or stored on magnetic or other media), or provided as a stand-alone computer software product, and includes any accompanying printed materials and any "online" or electronic documentation ("Software"). The Software also includes any CTCT software (including, without limitation, upgrades and updates) relating to the Product that is furnished by Trimble Navigation Limited ("Trimble") or its dealers (including, without limitation, CTCT software downloaded from Trimble's or its dealers' website(s)) unless accompanied by different license terms and conditions that will govern its use.

BY CLICKING "YES" OR "I ACCEPT" IN THE ACCEPTANCE BOX, OR BY INSTALLING, COPYING OR OTHERWISE USING THE SOFTWARE, YOU AGREE TO BE BOUND BY THE TERMS OF THIS AGREEMENT. IF YOU DO NOT AGREE TO THE TERMS OF THIS AGREEMENT, DO NOT USE THE PRODUCT OR COPY THE SOFTWARE. INSTEAD PROMPTLY RETURN THE UNUSED SOFTWARE AND ACCOMPANYING PRODUCT TO THE PLACE FROM WHICH YOU OBTAINED THEM FOR A FULL REFUND.

### 1 SOFTWARE PRODUCT LICENSE

1.1 License Grant. Subject to this Agreement, CTCT grants you a limited, non-exclusive, non-sublicensable right to use one (1) copy of the Software in a machine-readable form on the Product. Such use is limited to use with the Product for which it was intended and into which it was embedded. You may use the installation Software from a computer solely to download the Software to one Product. In no event shall the installation Software be used to download the Software onto more than one Product without securing a separate license. A license for the Software may not be shared or used concurrently on different computers or Products.

### 1.2 Other Rights and Limitations.

- (1) You may not copy, modify, make derivative works of, rent, lease, sell, distribute or transfer the Software, in whole or in part, except as otherwise expressly authorized under this Agreement, and you agree to use all commercially reasonable efforts to prevent its unauthorized use and disclosure.
- (2) The Software contains valuable trade secrets proprietary to CTCT and its licensors. You shall not, nor allow any third party to copy, decompile, disassemble or otherwise reverse engineer the Software, or attempt to do so, provided, however, that to the extent any applicable mandatory laws (such as, for example, national laws implementing EC Directive 91/250 on the Legal Protection of Computer Programs) give you the right to perform any of the aforementioned activities without CTCT's consent in order to gain certain information about the Software for purposes specified in the respective statutes (i.e., interoperability), you hereby agree that, before exercising any such rights, you shall first request such information from CTCT in writing detailing the purpose for which you need the information. Only if and after CTCT, at its sole discretion, partly or completely denies your request, may you exercise such statutory rights.
- (3) This Software is licensed as a single product. You may not separate its component parts for use on more than one Product.
- (4) You may not rent, lease, or lend, the Software separate from the Product for which it was intended.
- (5) No service bureau work, multiple-user license or time-sharing arrangement is permitted. For purposes of this Agreement "service

bureau work" shall be deemed to include, without limitation, use of the Software to process or to generate output data for the benefit of, or for purposes of rendering services to any third party over the Internet or other communications network.

- (6) You may permanently transfer all of your rights under this Agreement only as part of a permanent sale or transfer of the Product for which it was intended, provided you retain no copies, you transfer all of the Software (including all component parts, the media and printed materials, any upgrades, and this Agreement) and the recipient agrees to the terms of this Agreement. If the Software portion is an upgrade, any transfer must include all prior versions of the Software.
  - (7) You acknowledge that the Software and underlying technology may be subject to the export administration regulations of the United States Government relating to the export of technical data and products. This Agreement is subject to, and you agree to comply with, any laws, regulations, orders or other restrictions on the export of the Software from the United States which may be imposed by the United States Government or agencies thereof.
  - (8) At the request of CTCT, you agree to cooperate with CTCT to track the number of Products using Software at your site(s) to ensure compliance with the license grant and installation restrictions in this Agreement.
  - (9) Notwithstanding anything to the contrary in this Agreement, any Open Source Software that may be included as a part of the software package shall not constitute a portion of the Software as defined in this Agreement and is not licensed under the terms of this Agreement, but instead is subject to the terms of the applicable Open Source Software license. Unless otherwise required pursuant to the terms of an Open Source Software license, CTCT grants you no right to receive source code to the Open Source Software; however, in some cases rights and access to source code may be available to you directly from the licensors. If you are entitled to receive the source code from CTCT for any Open Source Software included with the software package, you may obtain the source code at no charge by written request to CTCT at Caterpillar Trimble Control Technologies LLC, 5475 Kellenburger Rd., Dayton, Ohio 45424 USA, Attn: GCS, CCS and PCS Series Products Manager. You must agree to the terms of the applicable Open Source Software license, or you may not use the subject Open Source Software.
- For purposes of this Agreement, "Open Source Software" means those software programs or libraries that are identified in the software documentation, read me and/or about files as being subject to any open source software license, and all modifications, derivative works and executables based on or derived from such software programs or libraries, if such modifications, derivative works and/or executables are also subject to the applicable open source software license by its terms.
- 1.3 Termination. You may terminate this Agreement by ceasing all use of the Software. Without prejudice as to any other rights, CTCT may terminate this Agreement without notice if you fail to comply with the terms and conditions of this Agreement. In either event, you must destroy all copies of the Software and all of its component parts, and provide an affidavit to CTCT stating that you have done the same.
  - 1.4 Copyright. All title and copyrights in and to the Software (including but not limited to any images, photographs, animations, video, audio, music, and text incorporated into the Software), the accompanying printed materials, and any copies of the Software are owned by CTCT and its licensors. You shall not remove, cover or alter any of CTCT's patent, copyright or trademark notices placed upon, embedded in or displayed by the Software or on its packaging and related materials.
  - 1.5 U.S. Government Restricted Rights. The Software is provided with "RESTRICTED RIGHTS". Use, duplication, or disclosure by the United States Government is subject to restrictions as set forth in this Agreement, and as provided in DFARS 227.7202-1(a) and 227.7202-3 (a)(1995), DFARS 252.227-7013(c)(1)(ii) (OCT 1988), FAR 12.212(a) (1995), FAR 52.227-19, or FAR 52.227-14(ALT III), as applicable.

## 2 LIMITED WARRANTY

2.1 Limited Warranty. CTCT warrants that the Software will perform substantially in accordance with the accompanying written materials for a period of one (1) year from the date of receipt. This limited warranty gives you specific legal rights, you may have others, which vary from state/jurisdiction to state/jurisdiction.

2.2 Customer Remedies. CTCT's and its licensors' entire liability, and your sole remedy, with respect to the Software shall be either, at CTCT's option, (a) repair or replacement of the Software, or (b) return of the license fee paid for any Software that does not meet CTCT's limited warranty. This limited warranty is void if failure of the Software has resulted from (1) accident, abuse, or misapplication; (2) alteration or modification of the Software without CTCT's prior written authorization; (3) interaction with software or hardware not supplied by CTCT or Trimble; (4) improper, inadequate or unauthorized installation, maintenance, or storage of the Software or Product; or (5) if you violate the terms of this Agreement. Any replacement Software will be warranted for the remainder of the original warranty period or thirty (30) days, whichever is longer.

2.3 NO OTHER WARRANTIES. TO THE MAXIMUM EXTENT PERMITTED BY APPLICABLE LAW, CTCT AND ITS LICENSORS DISCLAIM ALL OTHER WARRANTIES AND CONDITIONS, EITHER EXPRESS OR IMPLIED, INCLUDING BUT NOT LIMITED TO, IMPLIED WARRANTIES AND CONDITIONS OF MERCHANTABILITY AND FITNESS FOR A PARTICULAR PURPOSE, TITLE, AND NON INFRINGEMENT WITH REGARD TO THE SOFTWARE AND THE PROVISION OF OR FAILURE TO PROVIDE SUPPORT SERVICES. THE ABOVE LIMITED WARRANTY DOES NOT APPLY TO ERROR CORRECTIONS, UPDATES OR UPGRADES OF THE SOFTWARE AFTER EXPIRATION OF THE LIMITED WARRANTY PERIOD, WHICH ARE PROVIDED "AS IS" AND WITHOUT WARRANTY. BECAUSE THE SOFTWARE IS INHERENTLY COMPLEX AND MAY NOT BE COMPLETELY FREE OF NONCONFORMITIES, DEFECTS OR ERRORS, YOU ARE ADVISED TO VERIFY YOUR WORK. CTCT DOES NOT WARRANT THE RESULTS OBTAINED THROUGH USE OF THE SOFTWARE, OR THAT THE SOFTWARE WILL OPERATE ERROR FREE OR UNINTERRUPTED, WILL MEET YOUR NEEDS OR EXPECTATIONS, OR THAT ALL NONCONFORMITIES CAN OR WILL BE CORRECTED. TO THE EXTENT ALLOWED BY APPLICABLE LAW, IMPLIED WARRANTIES AND CONDITIONS ON THE SOFTWARE ARE LIMITED TO ONE (1) YEAR. YOU MAY HAVE OTHER LEGAL RIGHTS WHICH VARY FROM STATE/JURISDICTION TO STATE/JURISDICTION.

2.4 LIMITATION OF LIABILITY. CTCT'S ENTIRE LIABILITY UNDER ANY PROVISION OF THIS AGREEMENT SHALL BE LIMITED TO THE GREATER OF THE AMOUNT PAID BY YOU FOR THE SOFTWARE LICENSE OR U.S. \$25.00. TO THE MAXIMUM EXTENT PERMITTED BY APPLICABLE LAW, IN NO EVENT SHALL CTCT OR ITS LICENSORS BE LIABLE FOR ANY SPECIAL, INCIDENTAL, INDIRECT OR CONSEQUENTIAL DAMAGES WHATSOEVER (INCLUDING, WITHOUT LIMITATION, DAMAGES FOR LOSS OF BUSINESS PROFITS, BUSINESS INTERRUPTION, LOSS OF BUSINESS INFORMATION, OR ANY OTHER PECUNIARY LOSS) ARISING OUT OF THE USE OR INABILITY TO USE THE SOFTWARE, OR THE PROVISION OF OR FAILURE TO PROVIDE SUPPORT SERVICES, EVEN IF CTCT HAS BEEN ADVISED OF THE POSSIBILITY OF SUCH DAMAGES. BECAUSE SOME STATES AND JURISDICTIONS DO NOT ALLOW THE EXCLUSION OR LIMITATION OF LIABILITY FOR CONSEQUENTIAL OR INCIDENTAL DAMAGES, THE ABOVE LIMITATION MAY NOT APPLY TO YOU.

## 3 GENERAL

3.1 This Agreement shall be governed by the laws of the State of Ohio and applicable United States Federal law without reference to "conflict of laws" principles or provisions. The United Nations Convention on Contracts for the International Sale of Goods will not apply to this Agreement. Jurisdiction and venue of any dispute or court action arising from or related to this Agreement or the Software shall lie exclusively in or be transferred to the courts of the Montgomery County, Ohio, and/or the United States District Court for Ohio. You hereby consent and agree not to contest, such jurisdiction, venue and governing law.

3.2 Notwithstanding Section 3.1, if you acquired the Product in Canada, this Agreement is governed by the laws of the Province of Ontario, Canada. In such case each of the parties to this Agreement irrevocably attorns to the jurisdiction of the courts of the Province of Ontario and further agrees to commence any litigation that may arise under this Agreement in the courts located in the Judicial District of York, Province of Ontario.

3.3 Official Language. The official language of this Agreement and of any documents relating thereto is English. For purposes of interpretation, or in the event of a conflict between English and versions of this Agreement or related documents in any other language, the English language version shall be controlling.

3.4 CTCT reserves all rights not expressly granted by this Agreement. 2015©, Caterpillar Trimble Control Technologies LLC. All Rights Reserved.



# Safety Information

Most accidents that involve product operation, maintenance and repair are caused by failure to observe basic safety rules or precautions. An accident can often be avoided by recognizing potentially hazardous situations before an accident occurs. A person must be alert to potential hazards. This person should also have the necessary training, skills and tools to perform these functions properly.

Improper operation, lubrication, maintenance or repair of this product can be dangerous and could result in injury or death.

Do not operate or perform any lubrication, maintenance or repair on this product, until you have read and understood the operation, lubrication, maintenance and repair information.

Safety precautions and warnings are provided in this manual and on the product. If these hazard warnings are not heeded, bodily injury or death could occur to you or to other persons.

The hazards are identified by the “Safety Alert Symbol” and followed by a “Signal Word” such as “DANGER”, “WARNING” or “CAUTION”. The Safety Alert “WARNING” label is shown below.



**WARNING** — This alert warns of a potential hazard which, if not avoided, can cause severe injury.

---

The meaning of this safety alert symbol is as follows:

***Attention! Become Alert! Your Safety is Involved.***

The message that appears under the warning explains the hazard and can be either written or pictorially presented.

Operations that may cause product damage are identified by “NOTICE” labels on the product and in this publication.

Trimble cannot anticipate every possible circumstance that might involve a potential hazard. The warnings in this publication and on the product are, therefore, not all inclusive. If a tool, procedure, work method or operating technique that is not specifically recommended by Trimble is used, you must satisfy yourself that it is safe for you and for others. You should also ensure that the product will not be damaged or be made unsafe by the operation, lubrication, maintenance or repair procedures that you choose.

The information, specifications, and illustrations in this publication are on the basis of information that was available at the time that the publication was written. The specifications, torques, pressures, measurements, adjustments, illustrations, and other items can change at any time. These changes can affect the service that is

given to the product. Obtain the complete and most current information before you start any job. Dealers have the most current information available.

### **Safety (Laser)**

The IEC and the United States Government Center of Devices for Radiology Health (CDRH) has classified this laser as a Class II laser product. The maximum radiant power output of this laser is less than 5 milliwatts.

Refer to the operator's manual of the laser transmitter for installation and operating instructions.

The laser supplied with your Laser System complies with all applicable portions of "Title 21" of the "Code of Federal Regulations, Department of Health and Human Services, Food and Drug Administration, Federal Register, Volume 50, Number 161, 20 August 1985".

This laser complies with "OSHA Standards Act, Section 1518.54" for use without eye protection. Eye protection is not required or recommended. The following safety rules should be observed:

- Never look into a laser beam or point the beam into the eyes of other people. Set the laser at a height that prevents the beam from flashing directly into people's eyes.
- Do not remove any warning signs from the laser.
- Use of this product by personnel that are not trained on this product may result in exposure to hazardous laser light.
- If initial service requires the removal of the outer protective cover, removal of the cover must be performed by trained personnel.

### **Crushing Prevention and Cutting Prevention**

Support the equipment properly when you work beneath the equipment. Do not depend on the hydraulic cylinders to hold up the equipment. An attachment can fall if a control is moved, or if a hydraulic line breaks.

Unless you are instructed otherwise, never attempt adjustments while the machine is moving. Also, never attempt adjustments while the engine is running.

Whenever there are attachment control linkages, the clearance in the linkage area will increase or the clearance in the linkage area will decrease with movement of the attachment. Stay clear of all rotating and moving parts.

Keep objects away from moving fan blades. The fan blade will throw objects or cut objects.

Do not use a kinked wire cable or a frayed wire cable. Wear gloves when you handle wire cable.

When you strike a retainer pin with force, the retainer pin can fly out. The loose retainer pin can injure personnel. Make sure that the area is clear of people when you strike a retainer pin. In order to avoid injury to your eyes, wear protective glasses when you strike a retainer pin.

Chips or other debris can fly off objects when you strike the objects. Make sure that no one can be injured by flying debris before striking any object.

## Operation

Clear all personnel from the machine and from the area.

Clear all obstacles from the machine's path. Beware of hazards (wires, ditches, etc).

Be sure that all windows are clean.

Secure the doors and the windows in the open position or in the shut position.

Adjust the rear mirrors (if equipped) for the best visibility close to the machine.

Make sure that the horn, the travel alarm (if equipped), and all other warning devices are working properly.

Fasten the seat belt securely.

Warm up the engine and the hydraulic oil before operating the machine.

Only operate the machine while you are in a seat.

The seat belt must be fastened while you operate the machine. Only operate the controls while the engine is running.

While you operate the machine slowly in an open area, check for proper operation of all controls and all protective devices. Before you move the machine, you must make sure that no one will be endangered.

Do not allow riders on the machine unless the machine has the following equipment:

- Additional seat
- Additional seat belt
- Rollover Protective Structure (ROPS)

Note any needed repairs during machine operation. Report any needed repairs.

Maintain control of the machine.

Do not overload the machine beyond the machine capacity.

Be sure that the hitches and the towing devices are adequate.

Never straddle a wire cable. Never allow other personnel to straddle a wire cable.

Before you maneuver the machine, make sure that no personnel are between the machine and the trailing equipment.

Always keep the Rollover Protective Structure (ROPS) installed during machine operation.

Monitor the location of mounted components. Ensure that the components do not come into contact with other parts of the machine during operation.

## Warnings



---

**WARNING** — When replacement parts are required for this product Trimble recommends using Trimble replacement parts or parts with equivalent specifications including, but not limited to, physical dimensions, type, strength and material. Failure to heed this warning can lead to premature failures, product damage, personal injury or death.

---



---

**WARNING** — When transporting machines with removable sensors such as GNSS receivers or UTS targets installed, if the sensor mounting bracket clamp loosens, then the sensor may be dislodged from the machine which may result in injury or death. Always remove and store removable sensors prior to transport.

---



---

**WARNING** — When removing or installing removable sensors such as GNSS receivers or UTS targets, if the sensor is accessed improperly, then a fall may result in injury or death. Always follow site, state or national Health and Safety guidelines when removing or installing removable sensors.

---



---

**WARNING** — Do not operate this system unless you are fully trained on this equipment and end-use equipment.

The cutting edge of the machine may move without warning when automatic controls are on. These sudden movements could cause injury to anyone near the cutting edge, or damage to the machine. Always put the system in Manual and engage the machine's park brake before you leave the machine, or when somebody is working near the cutting edge.

When the blade is not in operation, leaving it in the air could cause injury to you and others, or damage to the vehicle. Always place the blade on the ground when it is not in use.

As the system equipment may extend beyond the extents of the blade, operating the machine close to people and objects could cause injury to them or damage to the vehicle or system equipment. Maintain adequate clearance from people and objects when operating the vehicle.

The blade may move abruptly during hydraulic valve calibration. To avoid injury, make sure the machine's park brake is engaged, and that the calibrations are supervised by an operator in the machine cab. Maintain adequate clearance from people and objects during the hydraulic valve calibration.

---

# Contents

- Safety Information ..... 5**
- 1 About This Manual ..... 15**
  - 1.1 Introduction ..... 16
  - 1.2 Scope and audience ..... 16
  - 1.3 Related documentation ..... 16
  - 1.4 Trimble training classes and technical assistance ..... 17
  - 1.5 To learn more about Trimble ..... 17
  - 1.6 Your comments ..... 17
- 2 About the GCS900 Grade Control System ..... 19**
  - 2.1 Introduction ..... 20
  - 2.2 System components ..... 20
  - 2.3 Guidance levels and guidance information ..... 20
  - 2.4 Office integration ..... 26
    - 2.4.1 SiteVision Office ..... 26
    - 2.4.2 VisionLink™ ..... 28
    - 2.4.3 Connected Community ..... 29
    - 2.4.4 Business Center ..... 34
    - 2.4.5 Remote Assistant ..... 35
- 3 Control Box Features ..... 37**
  - 3.1 The CB450 and CB460 control boxes ..... 38
  - 3.2 Guidance screens ..... 39
    - 3.2.1 Plan view ..... 40
    - 3.2.2 Map recording views ..... 41
    - 3.2.3 Cross-section view ..... 42
    - 3.2.4 Profile view ..... 43
    - 3.2.5 Split view ..... 44
    - 3.2.6 Level view ..... 45
    - 3.2.7 Text view 1 and text view 2 ..... 45
    - 3.2.8 Zooming the view ..... 46
    - 3.2.9 Panning the view ..... 47
    - 3.2.10 Dark background mode ..... 47
  - 3.3 Warnings and other messages ..... 48
    - 3.3.1 Full screen warnings ..... 48
    - 3.3.2 Flashing warnings ..... 48
    - 3.3.3 Messages from the site office ..... 49
  - 3.4 Wireless communications with the office ..... 50

3.5	Machine configuration files .....	50
3.6	Control box settings files .....	51
3.7	Diagnostics text file .....	51
<b>4</b>	<b>Sensors .....</b>	<b>53</b>
4.1	Introduction .....	54
4.2	3D sensors .....	54
	4.2.1 GNSS receivers .....	54
	4.2.2 Trimble UTS robotic total station .....	64
4.3	Angle sensors .....	65
	4.3.1 AS400 slope sensor .....	66
	4.3.2 AS450, LC450 and AS456 angle sensors .....	66
	4.3.3 AS460 dual axis sensor .....	69
	4.3.4 GS420 inertial sensor .....	69
4.4	Lift sensors .....	70
	4.4.1 LR410 laser receiver .....	70
	4.4.2 ST400 sonic tracer .....	71
4.5	RS400 rotation sensor .....	72
4.6	Sensor groups .....	73
	4.6.1 Cross slope sensor group .....	73
	4.6.2 The "Blade-on-Ground" sensor group .....	74
4.7	HS410 heading sensor .....	74
4.8	Cat PSC system .....	75
4.9	SR300 survey laser receiver .....	76
<b>5</b>	<b>Wireless Radios .....</b>	<b>79</b>
5.1	Introduction .....	80
5.2	Broadcast Radio Modems .....	80
	5.2.1 SNRx10 multi-band radio modems .....	80
	5.2.2 SNRx20 multi-band radio modems .....	82
5.3	Cellular modems .....	83
	5.3.1 The Trimble SNM940 Data Communications Module .....	83
	5.3.2 Third-party cellular modems .....	84
5.4	Wi-Fi networking .....	84
	5.4.1 The Trimble SNM940 Data Communications Module .....	85
	5.4.2 SNRx20 multi-band radio modems .....	86
	5.4.3 Third-party wireless networking devices .....	87
	5.4.4 Wireless WiFi Terminology .....	87
<b>6</b>	<b>Other Devices .....</b>	<b>91</b>
6.1	Introduction .....	92
6.2	EM400 electric mast .....	92
6.3	PM400 power module .....	93
6.4	LB400 external lightbars .....	93

---

6.4.1	Understanding lightbar information .....	94
6.5	Valve modules .....	100
6.5.1	The VM410 valve module .....	101
6.5.2	The VM415 valve module .....	102
6.5.3	The VM420 valve module .....	102
6.5.4	The VM430 valve module .....	103
6.6	USB keyboard .....	104
<b>7</b>	<b>Design Surfaces, Vertical Guidance, and Offsets .....</b>	<b>105</b>
7.1	Introduction .....	106
7.2	Specifying a design surface .....	106
7.2.1	Conventional design surfaces and benching .....	106
7.2.2	3D design surfaces and design files .....	108
7.3	Vertical offset .....	112
<b>8</b>	<b>Conventional Guidance Systems .....</b>	<b>117</b>
8.1	Introduction .....	118
8.2	Conventional guidance methods .....	118
8.2.1	Blade slope guidance .....	118
8.2.2	Lift guidance .....	121
8.2.3	Lift plus blade slope guidance .....	123
8.2.4	Cross slope guidance .....	125
8.2.5	Lift plus cross slope guidance .....	127
8.2.6	Independent lift-lift guidance .....	130
8.2.7	Linked lift-lift guidance .....	132
8.3	Sensor swap .....	135
8.4	Automatic slope swap .....	135
8.5	Dip reduction (blade rotation compensation) .....	135
<b>9</b>	<b>Excavator 2D Guidance Systems .....</b>	<b>137</b>
9.1	Introduction .....	138
9.2	Depth guidance .....	138
9.3	Depth-slope guidance .....	140
9.4	Depth dual slope guidance .....	141
9.5	Profile guidance .....	143
9.6	Alignments with profiles .....	144
9.7	Measure mode .....	146
9.8	Establishing an elevation reference .....	147
9.8.1	Elevation from a laser plane .....	147
9.8.2	Elevation from a benchmark .....	148
<b>10</b>	<b>3D Guidance Systems .....</b>	<b>151</b>
10.1	Introduction .....	152
10.2	Overview of 3D guidance .....	152

10.3	3D design files .....	152
10.3.1	Avoidance zones .....	153
10.3.2	On-screen linework .....	157
10.4	3D guidance surfaces .....	160
10.4.1	Reference surfaces .....	161
10.4.2	Layered lifts .....	162
10.4.3	Perpendicular lifts .....	170
10.4.4	Vertical lifts .....	172
10.5	Lane guidance .....	173
10.5.1	Lane guidance indicator .....	176
10.5.2	Extended lane guidance .....	177
10.5.3	Master alignment .....	177
10.6	3D guidance sensors .....	179
10.7	3D guidance methods .....	180
10.7.1	One-point center 3D guidance .....	181
10.7.2	One-point focus 3D guidance .....	184
10.7.3	Two-points tips 3D guidance .....	187
10.8	Switching between conventional and 3D guidance systems .....	189
10.9	Cut adjustment .....	189
10.10	Horizontal guidance .....	191
10.10.1	Road design alignments .....	192
10.10.2	Road design layered lift alignments .....	195
10.10.3	Horizontal guidance to a dynamic layered lift alignment .....	195
10.10.4	Road design side slopes .....	199
10.10.5	3D lines .....	199
10.10.6	Sloping surface master alignment .....	200
10.10.7	Plan lines .....	202
10.10.8	Horizontal offsets .....	203
10.11	Machine orientation and pitch .....	205
<b>11</b>	<b>Hybrid guidance systems .....</b>	<b>207</b>
11.1	Introduction .....	208
11.2	Overview of hybrid guidance .....	208
11.3	3D plus sonic tracer guidance .....	208
11.3.1	3D plus sonic tracer sensors .....	209
11.3.2	3D plus sonic tracer guidance views .....	210
<b>12</b>	<b>Production Reporting and Map Recording .....</b>	<b>211</b>
12.1	Production reporting for the office .....	212
12.2	Map recording .....	212
12.2.1	Automatic mapping .....	213
12.2.2	Terrain map recording .....	215
12.2.3	Cut/Fill map recording .....	216
12.2.4	Pass count map recording .....	217
12.2.5	Ripper map recording .....	218



12.2.6	Radio coverage map recording .....	218
12.2.7	Record points .....	219
12.2.8	Reset map .....	220
<b>13</b>	<b>Automatic Controls .....</b>	<b>221</b>
13.1	Automatic controls overview .....	222
13.2	Automatic control states .....	222
13.2.1	Manual .....	223
13.2.2	Auto .....	224
13.2.3	Inactive-Auto .....	226
13.2.4	Unknown .....	228
13.3	Optimizing automatic controls .....	228
13.3.1	Valve speed .....	228
13.3.2	Valve tune .....	229
13.3.3	Vertical offset increment .....	229
13.4	Using automatic controls .....	229
	<b>Index .....</b>	<b>231</b>



## About This Manual

### In this chapter:

- Introduction
- Scope and audience
- Related documentation
- Trimble training classes and technical assistance
- To learn more about Trimble
- Your comments

This section provides information on how this manual fits into the product's documentation set, where to go for further information, and how to provide feedback on Trimble® products and documentation.

## 1.1 Introduction

Welcome to the *Trimble GCS900 Grade Control System Reference Manual*. This manual provides conceptual information for the Trimble® GCS900 Grade Control System version 12.70.

## 1.2 Scope and audience

The intended audience for this manual are personnel who supervise the operation of, or operate, the GCS900 Grade Control System on machines. This includes personnel performing the following roles:

- Dealers
- Installation technicians
- Site supervisors
- Machine operators

This manual describes the concepts underlying the GCS900 Grade Control System. To learn about installing the system, refer to the installation manual for your machine type. To learn about managing the system on your machine, refer to the *Trimble GCS900 Grade Control System Site Supervisor's Manual*. To learn about day-to-day operation of the system, refer to the *Trimble GCS900 Grade Control System Operator's Manual*.

Even if you have used other machine guidance systems before, Trimble recommends that you spend some time reading this manual to learn about the special features of this product.

## 1.3 Related documentation

Trimble manuals that are related to this product are available in PDF format on the *Trimble GCS900 Grade Control System Software USB flash drive*. To view or print the manuals, use Adobe Reader (provided on the USB flash drive).

Utilities that do not have an accompanying manual have an integrated Help.

## 1.4 Trimble training classes and technical assistance

Contact your local Trimble dealer for:

- Technical support.
- Information about:
  - the support agreement contracts for software and firmware
  - extended warranty programs for hardware
  - training

## 1.5 To learn more about Trimble

For an interactive look at Trimble, visit [www.trimble.com](http://www.trimble.com).

If you are not familiar with GNSS, Trimble recommends that you complete the Introduction to GNSS tutorial at the Trimble Learning Center:  
[http://www.trimble.com/gps\\_tutorial/](http://www.trimble.com/gps_tutorial/).

## 1.6 Your comments

Your feedback about the supporting documentation helps us to improve it with each revision. Email your comments to [readerfeedback@trimble.com](mailto:readerfeedback@trimble.com).



## About the GCS900 Grade Control System

### In this chapter:

- Introduction
- System components
- Guidance levels and guidance information
- Office integration

This chapter describes the basic functionality of the Trimble GCS900 Grade Control System.

## 2.1 Introduction

The Trimble GCS900 Grade Control System is a rugged and reliable machine control system. The system uses a flexible array of sensors to determine the orientation of the machine's cutting edge, referenced to a surface, such as a laser plane, or 3D design. The measured position is then compared against a preset value, and any errors are fed back to the operator via the system's display and lightbars. An automatic control option is available that can also autonomously correct errors in the cutting edge position.

The system is designed specifically for earthmoving equipment in the earthmoving industry. Field-proven and versatile, the system simplifies grading processes, increases accuracy, saves time, and reduces the amount of material used.

## 2.2 System components

The core components of the system are the control box and integrated lightbars, which display guidance information, and the sensors which measure the attitude or position of the machine's main structures.

As sensors are added and removed, the type of guidance information the system can provide changes, and the system interfaces available to the operator also change.

The control box and the various sensors are connected electrically by a system harness that enables them to send data and commands between themselves.

## 2.3 Guidance levels and guidance information

The system can provide the following levels of guidance:

- Conventional (2D) guidance provides cutting edge guidance relative to an external reference such as a laser plane, string line or gravity, and is independent of the location of the machine.
- For 2D excavator systems with GNSS Receiver Support, 3D guidance is given *relative* to the benched point.
- 3D guidance uses the 3D location of the machine to provide cutting edge guidance relative to an internal 3D digital design. 3D guidance is useful for constructing complex designs, such as highways and curved banks.
- Hybrid guidance combines the features of 3D systems, such as providing grade information relative to a digital design, with the features of conventional systems, such as providing grade information relative to an existing surface.



Some sensor combinations support both 2D and 3D guidance, in which case the operator can quickly swap between 2D and 3D guidance.

In addition, each level of guidance can provide the types of cutting edge guidance information described in the following table:

This type of guidance ...	Is derived from the following information ...
Lift	The height of a single point on, or beyond, the cutting edge of the blade relative to an external reference.
Lift – lift	The height of two points on, or beyond, the cutting edge of the blade relative to an external reference. There are two types of two-point lift: linked and independent: <ul style="list-style-type: none"> <li>• Linked lift guidance uses a single reference elevation. This means that both sensors are benched at the same height.</li> <li>• Independent lift guidance uses two reference elevations. This means that each lift sensor is benched at a different height.</li> </ul>
Blade slope	The slope of the cutting edge, relative to a preset value.
Lift plus blade slope	The height of one end of the cutting edge relative to an existing reference surface, such as a string line, curb, or laser plane, and the slope of the cutting edge, relative to a preset value.
Cross slope	The slope of the cutting edge, projected in the direction of travel of the machine, relative to a preset value.
Lift plus cross slope	The height of one end of the cutting edge relative to an existing reference surface, for example: <ul style="list-style-type: none"> <li>• laser plane</li> <li>• sonic on string line</li> <li>• sonic on curb</li> </ul> <p><b>and</b> the cross slope of the cutting edge, relative to a preset value.</p>
One-point 3D	The height of the cutting edge relative to the elevation of a design surface directly below a single point on the blade, and the horizontal offset of one tip of the cutting edge relative to a design feature.
Two-point 3D	The height of the cutting edge relative to the elevations of a design surface directly below two separate points on the blade, and the horizontal distance of one tip of the cutting edge from a selected design feature.

The following table lists some typical sensor combinations used with a dozer system, the level of guidance the sensor combinations support, and the guidance information the system can provide.

Guidance level and information	3D sensor	2D sensors	Restrictions
2D <ul style="list-style-type: none"> <li>• Blade slope</li> </ul>		1 x AS400 blade slope or 1 x GS420	GS420 sensors are supported on a make/model/serial number basis. Contact your dealer for details.

Guidance level and information	3D sensor	2D sensors	Restrictions
2D <ul style="list-style-type: none"> <li>• Blade slope</li> <li>• Lift plus blade slope</li> </ul>		1 x <ul style="list-style-type: none"> <li>• AS400 blade slope</li> <li>• LR4x0 or SR300 lift</li> <li>• ST400 lift</li> </ul>	The mast must be perpendicular to the laser plane. The blade must be unrotated.
2D <ul style="list-style-type: none"> <li>• Lift-lift (linked and independent)</li> </ul>		2 x LR4x0 lift	The mast must be perpendicular to the laser plane.  Linked mode is only available when you have dual EM400s.
3D <ul style="list-style-type: none"> <li>• One-point</li> </ul>	1 x GNSS		Cab-mounted systems.  The blade must be level, unrotated, and in the normal working position.
3D <ul style="list-style-type: none"> <li>• One-point</li> </ul>	1 x GNSS		Blade mounted systems, with the mast in the measure-up position.  The blade must be level and unrotated.
3D <ul style="list-style-type: none"> <li>• One-point</li> <li>• Two-point</li> </ul>	1 x GNSS or 1 x UTS	1 x AS400 blade slope or 1 x GS420	The blade is unrotated and the mast is in the measure-up position. GS420 sensors are supported on a make/model/serial number basis. Contact your dealer for details.
3D <ul style="list-style-type: none"> <li>• One-point</li> <li>• Two-point</li> </ul>	1 x GNSS or 1 x UTS	1 x <ul style="list-style-type: none"> <li>• AS400 blade slope</li> <li>• AS400 mainfall</li> <li>• RS400 blade rotation</li> </ul>	The mast is in the measure-up position.
3D <ul style="list-style-type: none"> <li>• One-point</li> <li>• Two-point</li> </ul>	1 x GNSS or 1 x UTS	1 x <ul style="list-style-type: none"> <li>• AS400 blade slope or GS420</li> <li>• AS400 blade pitch</li> </ul>	The blade is unrotated.  GS420 sensors are supported on a make/model/serial number basis. Contact your dealer for details.
3D <ul style="list-style-type: none"> <li>• One-point</li> <li>• Two-point</li> </ul>	1 x GNSS or 1 x UTS	1 x <ul style="list-style-type: none"> <li>• AS400 blade slope</li> <li>• AS400 mainfall</li> <li>• RS400 blade rotation</li> <li>• AS400 blade pitch</li> </ul>	

Guidance level and information	3D sensor	2D sensors	Restrictions
3D <ul style="list-style-type: none"> <li>One-point</li> <li>Two-point</li> </ul>	2 x GNSS		The masts are in the measure-up position.
3D <ul style="list-style-type: none"> <li>One-point</li> <li>Two-point</li> </ul>	2 x GNSS	1 x <ul style="list-style-type: none"> <li>AS400 blade pitch</li> <li>AS400 mainfall</li> </ul>	

The following table lists some typical sensor combinations used with a motor grader system, the level of guidance the sensor combinations support, and the guidance information the system can provide.

Guidance level and information	Blade location sensor	Restrictions	Fixed sensors
2D <ul style="list-style-type: none"> <li>Blade slope</li> </ul>			1 x AS400 blade slope
2D <ul style="list-style-type: none"> <li>Cross slope</li> </ul>			1 x <ul style="list-style-type: none"> <li>AS400 blade slope</li> <li>AS400 mainfall</li> <li>RS400 blade rotation</li> </ul>
2D <ul style="list-style-type: none"> <li>Cross slope</li> <li>Lift plus cross slope</li> </ul>		The mast must be perpendicular to the laser plane.	1 x <ul style="list-style-type: none"> <li>ST400 or LR4x0 lift</li> <li>AS400 blade slope</li> <li>AS400 mainfall</li> <li>RS400 blade rotation</li> </ul>
2D <ul style="list-style-type: none"> <li>Lift-lift</li> </ul>		The mast must be perpendicular to the laser plane.	2 x LR4x0 lift
3D <ul style="list-style-type: none"> <li>One-point</li> </ul>	1 x GNSS	Cab-mounted system. Assumes the blade is level, unrotated, and close to the design surface.	
3D <ul style="list-style-type: none"> <li>One-point</li> </ul>	1 x GNSS	Blade mounted system. Assumes the blade is level and unrotated. Assumes that the mast is in the measure-up position.	

Guidance level and information	Blade location sensor	Restrictions	Fixed sensors
3D <ul style="list-style-type: none"> <li>One-point</li> <li>Two-point</li> </ul>	1 x GNSS or 1 x UTS	Assumes that the mast is in the measure-up position.	1 x <ul style="list-style-type: none"> <li>AS400 blade slope</li> <li>AS400 mainfall</li> <li>RS400 blade rotation</li> </ul>
3D <ul style="list-style-type: none"> <li>One-point</li> <li>Two-point</li> </ul>	2 x GNSS	Assumes that the mast is in the measure-up position.	
3D <ul style="list-style-type: none"> <li>One-point</li> <li>Two-point</li> </ul>	1 x GNSS or 1 x UTS		1 x <ul style="list-style-type: none"> <li>AS400 blade pitch</li> <li>AS400 mainfall</li> <li>AS400 blade slope</li> <li>RS400 blade rotation</li> </ul>
3D <ul style="list-style-type: none"> <li>One-point</li> <li>Two-point</li> </ul>	2 x GNSS		1 x <ul style="list-style-type: none"> <li>AS400 blade pitch</li> <li>AS400 mainfall</li> </ul>
Hybrid <ul style="list-style-type: none"> <li>3D Dual GNSS + Sonic</li> </ul>	2 x GNSS and 1 x Sonic tracer		
Hybrid <ul style="list-style-type: none"> <li>3D Single GNSS + Sonic</li> </ul>	1 x GNSS and 1 x Sonic tracer	If only using an AS400 blade slope sensor instead of the cross slope sensor group then the blade must be square.	1 x <ul style="list-style-type: none"> <li>AS400 blade slope</li> </ul> or 1 x <ul style="list-style-type: none"> <li>AS400 mainfall</li> <li>AS400 blade slope</li> <li>RS400 blade rotation</li> </ul>
Hybrid <ul style="list-style-type: none"> <li>3D UTS + Sonic</li> </ul>	1 x UTS and 1 x Sonic tracer	If only using an AS400 blade slope sensor instead of the cross slope sensor group then the blade must be square.	1 x <ul style="list-style-type: none"> <li>AS400 blade slope</li> </ul> or 1 x <ul style="list-style-type: none"> <li>AS400 mainfall</li> <li>AS400 blade slope</li> <li>RS400 blade rotation</li> </ul>

**Note** – You can use an SR300 survey laser receiver with **single or dual-GNSS dozer and motor grader systems** to improve the vertical guidance accuracy, but a survey laser receiver does not affect the type of guidance information the system provides.

**Note** – If the system includes a UTS or a GNSS receiver and SR300 combination, you can use an additional AS400 to measure the blade pitch when you bench the UTS or laser receiver.

The following table lists the sensor combinations used with an excavator system, the level of guidance the sensor combination supports, and the guidance information the system can provide.

Guidance level and information	Body sensors	Machine location sensor	Arm location sensors	Bucket slope (tilt) sensor	VA Boom	Cab Rotation sensor
2D <ul style="list-style-type: none"> <li>• Depth</li> <li>• Depth and Slope</li> <li>• Profile</li> </ul>	AS460		3 x AS450 or Cat PSC	AS45x	AS450	
2D <ul style="list-style-type: none"> <li>• Depth</li> <li>• Depth and Slope</li> <li>• Depth Dual Slope</li> <li>• Profile</li> </ul>	AS460		3 x AS450 or Cat PSC	AS45x	AS450	HS410
2D <ul style="list-style-type: none"> <li>• Depth</li> <li>• Depth and Slope</li> <li>• Profile</li> </ul> 3D <ul style="list-style-type: none"> <li>• One-point</li> <li>• Two-point</li> </ul>	AS460	2 x GNSS	3 x AS450	AS45x	AS450	
2D <ul style="list-style-type: none"> <li>• Depth</li> <li>• Depth and Slope</li> <li>• Profile</li> </ul> 3D <ul style="list-style-type: none"> <li>• One-point</li> <li>• Two-point</li> </ul>	AS460	1 x GNSS or 1 x MT900	3 x AS450	AS45x	AS450	

Guidance level and information	Body sensors	Machine location sensor	Arm location sensors	Bucket slope (tilt) sensor	VA Boom	Cab Rotation sensor
2D <ul style="list-style-type: none"> <li>• Depth</li> <li>• Depth and Slope</li> <li>• Depth Dual Slope</li> <li>• Profile</li> <li>• Alignments with Profiles (only available with GNS Receiver Support)</li> </ul>	AS460	1 x GNS (MS9x2)	3 x AS450	AS45x	AS450	

---

*Note – A combined laser detector/angle sensor, referred to as a laser catcher can be used instead of an angle sensor on the stick. An LC450 laser catcher can be used in place of an AS450 angle sensor.*

## 2.4 Office integration

You can transfer data between the on-machine system and the design office, either wirelessly or by using a USB flash memory device.

Data includes designs, machine configurations and productivity data.

### 2.4.1 SiteVision Office

SiteVision Office provides tools for the following functions:

- Converting third-party surface and road design files.
- Generating data in grade control system-compatible formats for export to construction machines such as dozers, graders, and excavators.
- Generating data in SCS900-compatible formats for export to the Trimble SCS900 Site Controller System. (SCS900 is used for setting out and checking grades on construction sites.)
- Viewing designs and design elements graphically.
- Tracking data.

Although SiteVision Office lets you manage data, you cannot use SiteVision Office to edit data – except for roads. This ensures that the design data does not change, and that you do not use incorrect data.

SiteVision Office is not a CAD package.

## Supported Data Types

SiteVision Office handles the following data types:

- Road designs
- TINs (Triangulated Irregular Networks)
- SiteVision designs
- Grids
- Slope and level designs
- 3D linework designs
- Background files
- Avoidance zones
- Calibration data
- Display configuration files
- Reference surfaces
- Recorded data files
- Radio coverage
- Work orders
- Production data files

## Wireless Option

The SiteVision Office Wireless Option is a separately purchasable module which lets you communicate with your machines in the field.

Using SiteVision Office Wireless Option you can complete the following tasks:

- Monitor the position and status of a machine, including the following:
  - Moving / stationary indication
  - Auto / manual indication
  - Currently loaded design
  - Current position on the design
- Display the machine position on the SiteVision Office plan view map
- Send files or messages to a machine
- View the contents of the machine USB flash drive
- Request files from a machine

- Request diagnostic information
- Take screen snaps

### Productivity Module

The SiteVision Office Productivity Module is a separately purchasable module which lets you analyze the production data (\*.tag files) collected by the GCS900 Grade Control System.

You can use SiteVision Office Productivity Module to complete the following tasks:

- Volume calculations:
  - between a Production Data filter and a design surface
  - between two Production Data filters
- Summary volume reporting – simple cut and fill volumes between the “surfaces”
- Detailed volume reporting:
  - total material moved by the machines
  - by machine or design
  - at user-selectable reporting intervals
  - broken down by gear (on supported systems)
  - chart of cut and fill volumes over time
  - exported to \*.xls, \*.csv, \*.html or \*.txt formats
- Display cut/fill maps between the Production Data and design surfaces

### 2.4.2 VisionLink™

VisionLink has powerful tools that allow you to import a digital design file from Business Center – HCE, monitor site productivity, and analyze production data.

The VisionLink 3D project monitoring 3D subscription plan requires the Trimble SNM940 Connected Site Gateway, and a GCS900 Grade Control System. This allows you to:

- Manage machines
- Track machine data
- Create near real-time 3D surface model, elevation and cut/fill maps
- Manage project data



## Supported Data Types

VisionLink handles the following data types:

- TINs (Triangulated Irregular Networks)
- Slope and level designs
- Background files
- Avoidance zones
- Calibration data
- Display configuration files
- Reference surfaces
- Radio coverage
- Production data files

## 3D Project Monitoring

VisionLink lets you analyze the production data (\*.tag files) collected by the machines in the following ways:

- Volume calculations:
  - between a Production Data filter and a design surface
  - between two Production Data filters
- Summary volume reporting – simple cut and fill volumes between the “surfaces”
  - total material moved by the machines
  - by machine or design
  - at user-selectable reporting intervals
  - exported to \*.xls and \*.csv formats
- Display cut/fill maps between the Production Data and design surfaces
- Elevation
- Pass count

### 2.4.3 Connected Community

Connected Community powered by Trimble is a service that enables construction businesses to manage and share information via their own unique website. Ideal for organization and project management, the Connected Community introduces

communication and collaboration capabilities to significantly increase efficiency and productivity.

By hosting all of an organization's information centrally, Connected Community is able to do what no other information management system in the construction industry can - it connects people.

Each organization can grant access to internal and external users. For example, a contractor may set up varying levels of access to project partners or guests such as engineers, sub-contractors, suppliers, head office, and clients. Members can then communicate and collaborate instantly, regardless of their location.

In machine control applications, you can exchange files between a machine in the field and a customer's space on the Connected Community website (<https://www.myconnectedsite.com>). There are a number of ways of moving data between the office and your site's filespace. You can manage the transfers manually or, for example, use third-party webdrive software to map a USB flash drive in SiteVision Office to the site's filespace.

Internet Base Station Service (IBSS) is run as a service through the Connected Community website. It can be shared between multiple project partners and job sites.

To join Connected Community, contact your dealer.

For more information on managing Connected Community sites, go to <https://www.myconnectedsite.com/site/tccsupport/tccsupport>.

Exchange of files between a machine in the field and a customer's space on the Connected Community website is called "file synchronization".

The system uses a standard synchronization protocol which looks at the modification time and presence of each file in turn to decide whether to download or upload content.

In addition, the system applies action rules to decide if it is valid to synchronize a file. These rules are described in the following sections.

### Synchronization action rules

There are synchronization action rules for both files and folders.

#### Action rules for files

Downloads occur if:

- The file has been categorized as downloadable (see [Downloadable files and folders, page 33](#)); and
- The file exists remotely and the remote file is not scheduled for deletion; and one of

- On the previous synchronization the file did not exist remotely; or
- The file does not exist locally; or
- It has been modified remotely since the last synchronization.

Uploads will occur if:

- The file has been categorized as downloadable (see [Downloadable files and folders, page 33](#)); and
- It exists locally and is not scheduled for deletion; and one of
  - It didn't exist locally previously; or
  - It doesn't exist remotely; or
  - It has been modified locally since the last synchronization.

The file will be removed locally if:

- The file has been categorized as downloadable (see [Downloadable files and folders, page 33](#)); and
- The remote file existed previously but is now not present; and
- The file exists locally.

The file will be removed remotely if:

- The file has been categorized as uploadable (see [Downloadable files and folders, page 33](#)); and
- The local file existed previously but is now not present; and
- The file exists remotely.

If, for any given file, the file state matches more than one action, the file is considered conflicted and nothing happens.

If a folder does not exist remotely and the system is transferring child files and/or sub-folders of that folder, the folder is created remotely.

### **Action rules for folders**

The folder will be removed locally if:

- The folder has been categorized as downloadable (see [Special files and folders, page 32](#)); and
- The folder exists locally; and
- The remote folder existed previously but is now not present.

The folder will be created locally if:

- The folder has been categorized as downloadable (see [Special files and folders, page 32](#)); and
- The folder does not exist locally; and
- The remote folder did not exist previously but now is present.

The folder will be removed remotely if:

- The folder has been categorized as uploadable (see [Special files and folders, page 32](#)); and
- The folder exists remotely; and
- The local folder existed previously but is now no longer present.

The folder will be created remotely if:

- The folder has been categorized as uploadable (see [Special files and folders, page 32](#)); and
- The folder does not exist remotely; and
- The local folder did not exist previously but is now present.

If, for any given folder, the folder state matches more than one action, the folder is considered conflicted and nothing happens.

If a folder does not exist remotely and the system is transferring child files and/or sub-folders of that folder, the folder is created remotely.

### **Special files and folders**

There are a number of file and folder names used both on the control box and on the Connected Community website as part of the synchronization protocol itself. These include:

- FTPSync.xml
- FTPSync.xml.tmp and FTPSync.xml.old
- <Filename>.part
- .locked.<Design Name>
- <Design Name>.bak
- .locked.<File name> and <File name>.bak

These files cannot be synchronized.

## Downloadable files and folders

The files and folders in the following sections have been categorized as downloadable.

### Files that are downloaded only

These files will be downloaded to the machine if found on the Connected Community file space. They will not be uploaded to the Connected Community from the machine. If these files are deleted on the Connected Community they will persist on the machine.

Designs (*.svd *.svl *.dc *.ttm *.tsd *.alg etc)	Option Keys
Avoidance Zones	Persistent Setting Files (*.psf)
Background Linework	Device Firmware Files (*.S)
GNSS Configuration Files (*.cfg *.acs *.cal)	Control Box Firmware (*.SG2/3/4)
Coordinate System Files (current.csd, *.ggf, *.dgp, *.sgf, *.dat)	

### Files that are uploaded only

These are files that have been created on the machine and are uploaded to the Connected Community. These files are deleted from the machine once the files have been successfully uploaded to the Connected Community.

Production Data Files (*.tag)	Diagnostic files (*.zsnap & *.gif)
-------------------------------	------------------------------------

### Files that are not downloaded or uploaded

These files are not transferred between the machine and the Connected Community. Since the release of v12.30 program log files (\*.old) are no longer uploaded to the Connected Community.

*.ats	*.exe	*.raw
*.bak	*.gsf	*.reg
*.bin	*.log	*.ssf
*.can	*.map	*.zlib
*.elf	*.old	
*.eph	*.pro	

**Files that are transferred both ways**

All other file types are synchronized between the machine and the Connected Community. This is where the data sync will ensure that the files are the same on both the machine and Connected Community. Part of this is ensuring that the actions on one device are reproduced in the other location.

An example of this would be where a design is on both the machine and the Connected Community. If the design is deleted on the Connected Community it will be deleted on the machine.

Primary file types that are synchronized are:

Excavator Profiles (*.profile)	Patch Files (*.patch.mch)
Display Files (*.dsp)	In Field Printer Files (*.txt in design folders)
Machine Files (*.mch)	Points Files (*.csv in design folders)

**Folders that are transferred both ways**

Design folders are synchronized both ways but the Design files are only downloaded.



**ATTENTION** — Where a design exists only on the machine and not on the Connected Community a Design folder will be created on the Connected Community. This is a location for uploading \*.csv and \*.txt files to. This folder can be an empty folder on the Connected Community but if it is deleted from the Connected Community the folder and all of the contents will be deleted from the machine.

An example of this would be where a design has been loaded by a USB flash drive or a slope or level has been created on the machine. An empty folder would be created on the Connected Community.



**CAUTION** — If the design that is currently being used on the machine is deleted on the Connected Community it will be unloaded and deleted during the next data sync.

GeoData folders are synchronized both ways but the files are only downloaded.

**2.4.4 Business Center**

Business Center powered by Trimble® – Heavy Construction Edition (HCE) is designed for construction professionals involved in construction data preparation and managing the provision of data to and from field crews. Using Business Center – HCE, contractors can import, review, and analyze graphical design information, then easily assign, manage, and track that information through the lifetime of a construction project. It ensures that field crews have accurate and up-to-date

information and optimizes the workflow of Trimble® SCS900 Site Controller Software.

Business Center – HCE creates a dynamic link between the project file and one or more controllers running the SCS900 Site Controller Software on the jobsite. Design data imported into Business Center – HCE from the project design process, is cleaned, edited, modeled, and converted into alignments, surfaces, and CAD linework data models. The data models can be reviewed in plan, spreadsheet, profile, cross section, or 3D views for errors and omissions before being assigned to any of the associated field crews as site or design data.

As a graphically-based data manager for the SCS900 Site Controller Software, it also allows a contractor to import and manipulate data prior to passing it through Trimble SiteVision Office for use with Trimble GCS900 Grade Control System. Business Center – HCE handles geodetic, field measurement, CAD, and design information, and provides specific workflows to manage information for a construction project. Plan, Profile, Cross section, spreadsheet, and 3D views are all dynamically linked, so edits in one view are automatically reflected in all other views and any associated surface models and contours.

#### **2.4.5 Remote Assistant**

Remote Assistant allows the operator to request online remote system support from you (the site supervisor) or the dealer. When enabled, the support person can view or take control of the operator's control box to assist with troubleshooting and/or training.

Remote Assistant is a separately purchasable option that requires a SNM940 radio and an active Connected Community session.

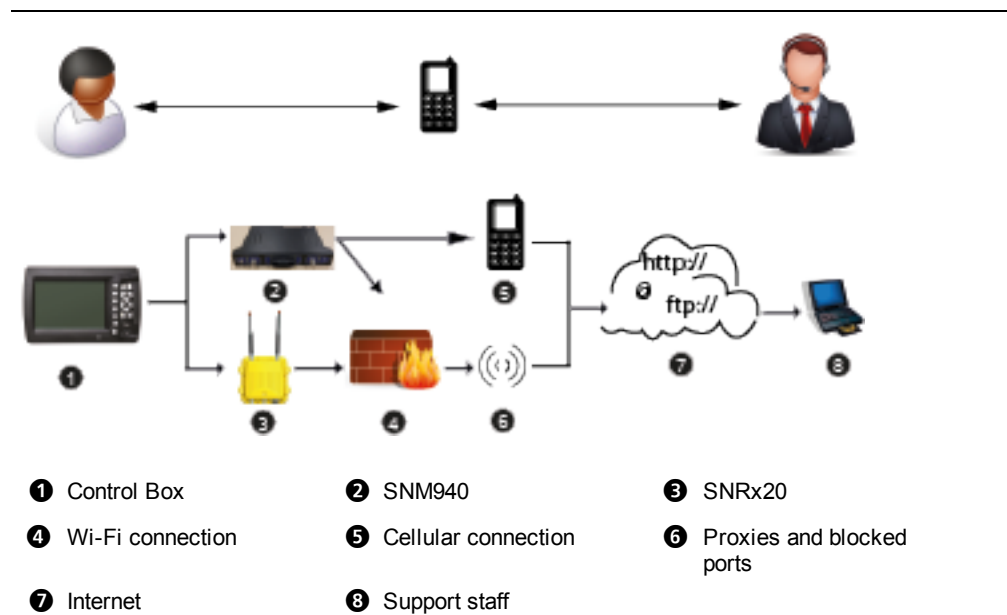

Figure 2.1 How Remote Assistant connects the operator to support staff

The remote user (support staff) will be able to:

- Navigate around the display remotely
- Toggle between Manager mode and Operator mode
- Interface with the file structure of the display through the existing Wireless Data Sync functionality with Connected Community. The following files can be accessed:
  - GNSS configuration files
  - Zsnap files
  - Design files
  - Tag files
- Take screen snaps or Zsnap files

***Note** – To view Zsnap files or any other files on the control box, a Wireless Data Sync is performed with the Connected Community. The operator will need to log in to their Connected Community site to download the files and email them to the remote user.*

The remote user will not be able to perform any actions that could cause the blade to move. This includes changing between Auto and Manual states and changing the vertical offset value.

For more information, refer to the *GCS900 Grade Control System Site Supervisor's Manual*.



## Control Box Features

### In this chapter:

- The CB450 and CB460 control boxes
- Guidance screens
- Warnings and other messages
- Wireless communications with the office
- Machine configuration files
- Control box settings files
- Diagnostics text file

This chapter describes how the control box and lightbars are used during the configuration and operation of the system.

### 3.1 The CB450 and CB460 control boxes

The system uses the control box as the primary user interface.

The CB450 and CB460 are cab-mounted ruggedized computing and communications devices with graphical true-color displays and integrated lightbars. They are designed for use in machine guidance and precision grade control applications in the mining or construction environments. The control boxes are designed for operation in harsh environments and can be quickly and easily removed for security when not in use.

Both control boxes share a similar look and feel, and can run the same applications. Files can be transferred to and from the control boxes via USB stick. A USB keyboard can be plugged into the USB port for data entry of dimensions and strings during installation.

*Note – The only supported file systems are FAT16 and FAT32. NTFS will not be recognized.*

The main differences between the control boxes are screen size, communications options, and external lightbar support. The smaller control box, the CB450, has a 4.3 inch screen, no Ethernet connections and does not support external lightbars. The larger control box, the CB460, has a 7 inch screen, an Ethernet connection and supports external lightbars.

The following figure shows a CB450 control box installed in the cab of an excavator.



The following tables list the physical and electrical characteristics of the control boxes.

**Table 3.1 — CB450 physical and electrical characteristics**

Item	Description
Dimensions	Front face: 200 x 115 x 30 mm Rear section: 164 x 98 x 25.5 mm Overall Size: 200 x 115 x 55.5 mm
Display	4.3 inch, 480(w) x 272(h) pixel
Weight	1.25 kg
Immersion	90 cm for 120 min
Pressure wash	SAE J1455
Salt and Fog	Mil-std-202F, 5% salt spray for 16 hours
Operating temperature	-20°C to +70°C
Operating voltage	9 V to 32 V
Power consumption	< 5 mA (standby), 2A max (operating)
Housing	High pressure die cast aluminum
Communications link	2x CAN, 3x RS-232

**Table 3.2 — CB460 physical and electrical characteristics**

Item	Description
Dimensions	Front face: 260 x 154 x 32 mm Rear section: 164 x 98 x 28 mm Overall Size: 260 x 154 x 60 mm
Display	7.0 inch, 800(w) x 480(h) pixel
Weight	2.25 kg
Immersion	90 cm for 120 min
Pressure wash	SAE J1455
Salt and Fog	Mil-std-202F, 5% salt spray for 16 hours
Operating temperature	-20°C to +65°C
Operating voltage	9 V to 32 V
Power consumption	< 5 mA (standby), 2A max (operating)
Housing	High pressure die cast aluminum
Communications link	2x CAN, 3x RS-232, 4x Ethernet

## 3.2 Guidance screens

While you work, you read guidance information from the system. One of the ways you do this is by working with guidance screens. Guidance screens display a mix of

text and graphics that provide information such as the attitude of the cutting edge or the position of the machine.

The availability of each guidance screen, and the information the screens contain, may vary according to the:

- Type of machine
- Sensors installed on the machine
- Availability of automatic controls
- Guidance configuration of the system
- Operator configuration of the system
- Type of design currently loaded

The guidance screens actually displayed are configured by the site supervisor.

The system provides the following guidance screens:

- Plan view
- Map recording views
- Cross-section view
- Profile view
- Split screen view
- Level view
- Text view 1
- Text view 2

To move between guidance screens, press .

### 3.2.1 Plan view

The plan view displays an overhead view of the site, and is useful for helping you navigate around the site, and positioning your machine on designs.

Plan view is only available when:

- one or more 3D sensors are installed and operating
- a site plan file, at least, is loaded

If it is available, plan view is the first guidance view the control box displays after startup.

The information that appears in the plan view varies according to the design type that you load.

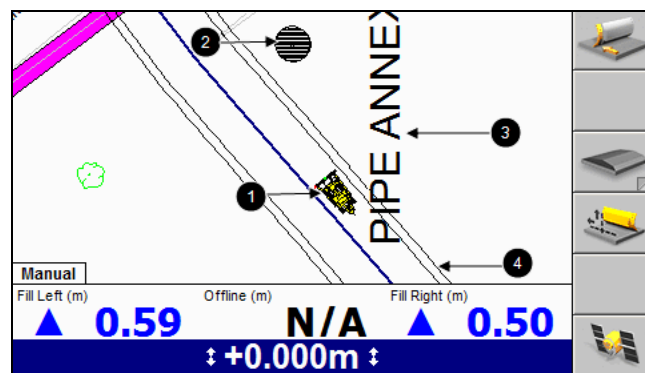

- |                  |                       |
|------------------|-----------------------|
| ❶ Machine icon   | ❷ Site plan line work |
| ❸ Site plan text | ❹ Design              |

Figure 3.1 An example of a plan view guidance screen

The site supervisor can configure the plan view either to rotate with the machine, or, to keep the design linework pointing north-up.

When the plan view is set to rotate, both the linework and the machine icon rotate to keep the machine pointing toward the top of the screen.

Map recording data can be displayed in the plan view. See [Chapter 12, Production Reporting and Map Recording](#).

### 3.2.2 Map recording views

If map recording is turned on, a number of mapping views are available in the guidance screens. These are:

- Terrain
- Cut/Fill
- Pass count
- Caterpillar Compaction Algorithm (Cat K Series landfill compactors only)
- Ripper
- Radio coverage

The following figure shows an example of cut/fill map recording.

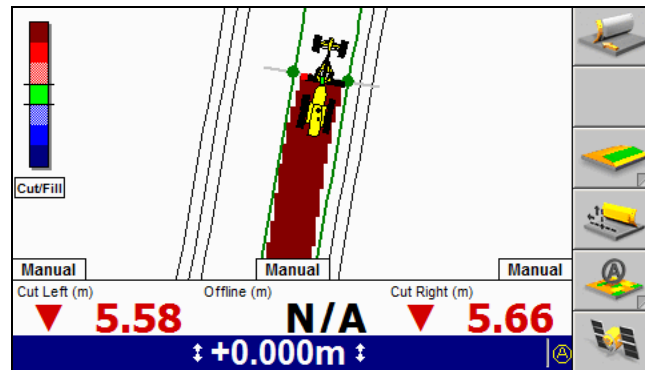

For more information, see [Chapter 12, Production Reporting and Map Recording](#).

### 3.2.3 Cross-section view

The cross-section view displays a cross-section of the design surface drawn through the center of the blade. The cross-section view is useful for monitoring the height of the cutting edge relative to the design surface, and the implement's distance from the horizontal alignment (if one is used).

For conventional guidance systems, cross-section view is the first guidance view the control box displays after start-up, and shows a design surface cross-section based on the set cross slope value.

For 3D guidance systems, when a design is loaded the cross-section view displays a cross-section of the design surface.

*Note* – On excavator systems the cross-section view is only available when a road (.dc) design file type is loaded. For all other design file types the split screen view is shown.

The guidance screen displays a cross-section of the job, at right angles to the direction of travel of the machine, from the point of view of the operator. The implement appears as if it were perpendicular to the direction of travel.

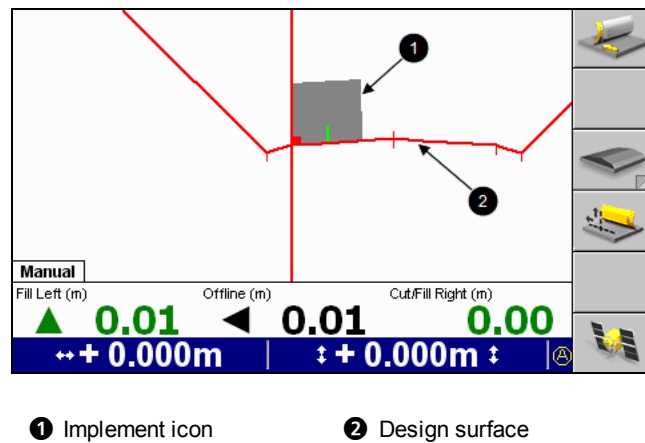

Figure 3.2 Example cross-section view

### 3.2.4 Profile view

If you choose a 3D guidance method, and load a design, then the profile view shows a longsection of the design surface.

The longsection is drawn through the blade tip that is receiving guidance, and in the direction the machine is traveling.

The profile view is available for all file types, *except* road designs (.dc files), and is useful when working on slopes and when operating an excavator. As the machine moves across the design, the design surface updates accordingly.

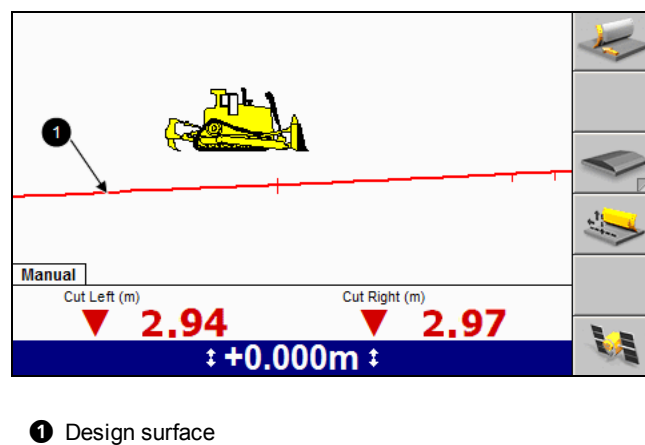
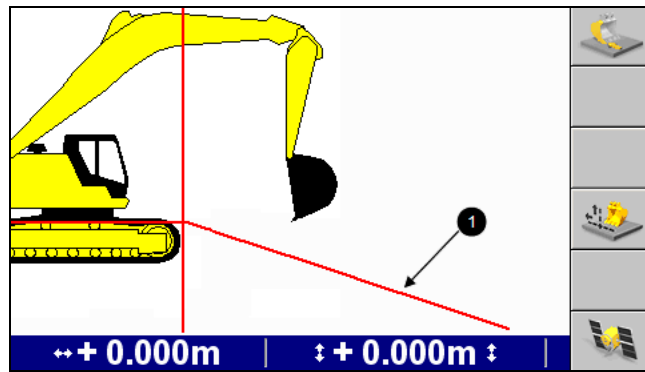

Figure 3.3 Example profile view

For excavators, the longsection is drawn through the bucket tip that has focus and is *parallel to the arm*. As the machine's body rotates, the design surface updates accordingly.



1 Design surface

Figure 3.4 Example profile view – excavator

### 3.2.5 Split view

The split screen view displays both the profile view (left hand side) and cross-section view (right hand side) in a single screen. Split screen view is useful for monitoring the position of the cutting edge, relative to the design surface.

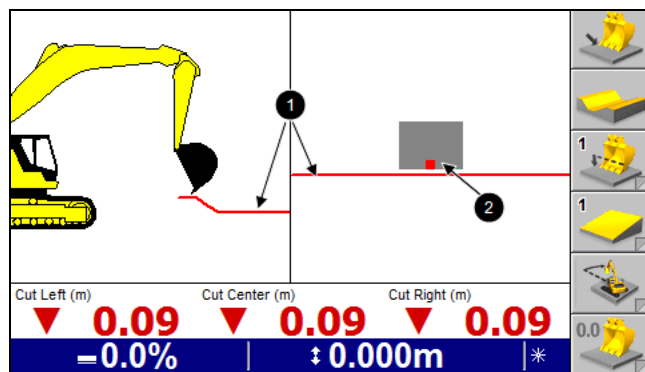

1 Design

2 Implement icon

Figure 3.5 Example split screen view

The split screen view is available by default on excavator systems when a design file type *other than* a road (.dc) is loaded. When you load a road file, only the cross-section view is available.

On other systems the split screen view is not available by default, but can be enabled via the *Main Screen Views* menu item.

*Note* – The split screen view replaces both the cross-section and profile views; when the split screen view is available, you cannot view the cross-section and profile views. Only the profile view supports zooming in and out, and only the cross section view supports auto-panning.



### 3.2.6 Level view

Level view displays the current pitch and roll of an excavator, and is useful for helping you to level the machine.

*Note – Level view is only available for excavator systems.*

Level view displays a level bubble, horizontal and vertical level bars and an angle measurement. The level bubble provides a visual representation of the current pitch and roll information coming from the pitch and roll sensor(s). The *Pitch* and *Roll* text items appear in level view by default.

The outer ring represents 45°; the inner ring represents 22.5°.

The bubble, the horizontal and vertical level bars, and text all update as the machine moves and the pitch and roll readings change.

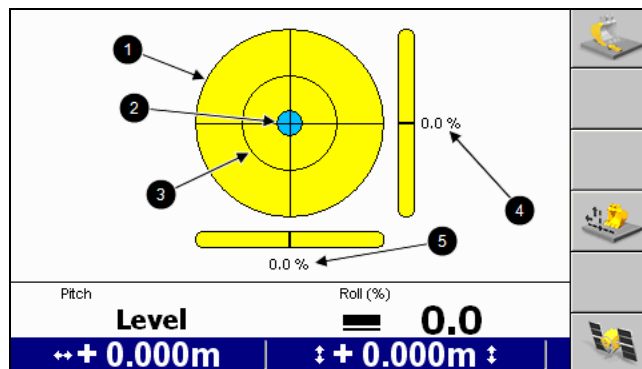

- ① Outer ring
- ② Level bubble
- ③ Inner ring
- ④ Machine pitch
- ⑤ Machine roll

Figure 3.6 An example of a level view

The level bubble units are the same as the Cross Slope units set in the *Units* dialog.

When the pitch and/or roll sensors are not connected, or when a value is not available, N/A appears for that value and the bubble does not appear.

### 3.2.7 Text view 1 and text view 2

The site supervisor configures the text items that display in text view 1 and text view 2. The following figure shows a text view guidance screen configured to display GNSS quality information.

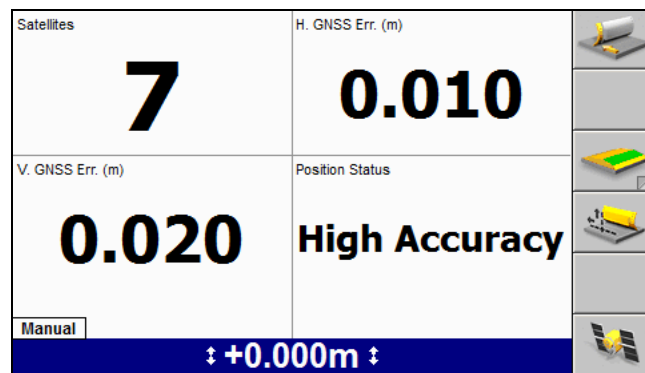



The example above shows:

- The number of GNSS satellites the system is using to generate guidance information
- The maximum estimated error in the horizontal GNSS position
- The maximum estimated error in the vertical GNSS position
- The position status

### 3.2.8 Zooming the view

There are four possible ways of zooming a view:

- Press  to zoom in on the current view.  
When you zoom in you see more detail on the screen. As you zoom in, less of the design and linework are shown. You can zoom in until the implement fills the screen.
- Press  to zoom out of the current view.  
When you zoom out you see less detail on the screen. As you zoom out, more of the design and linework are shown. You can zoom out so far that the machine symbol is hardly visible on the screen. When you zoom out this far, the machine symbol is no longer drawn to scale. This ensures you can always see the machine symbol in the current view.
- To view as much of the design as possible, press and hold .

Zoom all is only available when you use a conventional guidance method or when a 3D design is loaded.

In plan view, zoom all resizes the view so that the machine symbol and all linework are visible.

In cross-section and profile views, zoom all resizes the view to a maximum of 100 m (984 ft) on either side of the machine.

- To resize the current view around the machine symbol, press and hold .
- Zoom machine is only available when you use a conventional guidance method

or when a 3D design is loaded.

In plan view, zooming the machine will display five blade-widths around the machine.

In cross-section and profile views, zooming the machine will display two blade-widths on either side of the machine.



**Tip** – The system saves the sizes of the plan view, cross-section view, and profile view when you turn off the control box. The views automatically load at their previous size when you next use the system.

### 3.2.9 Panning the view

The system includes an automatic panning function that follows the machine icon as it moves around the design to ensure that the machine icon stays on the screen.

You can manually pan around the plan view to look at those parts of the design that are off the screen at the current zoom level. To pan manually, use the arrow keys to move the view. For example, press the right arrow key to show more of the plan to the right.

If the machine is moving, the view will return to the machine after the machine's position has changed by a small amount. If you need to pan further, stop the machine or disable the Auto pan feature in the *Main Screen Views* dialog.

### 3.2.10 Dark background mode

The main screen views can be run in dark background mode. This can be useful when working in low light conditions as it reduces the contrast between the display and the operating environment. It can also be used effectively at night in conjunction with the display brightness control.

For more information, refer to the *GCS900 Grade Control System Operator's Manual* for your machine type.

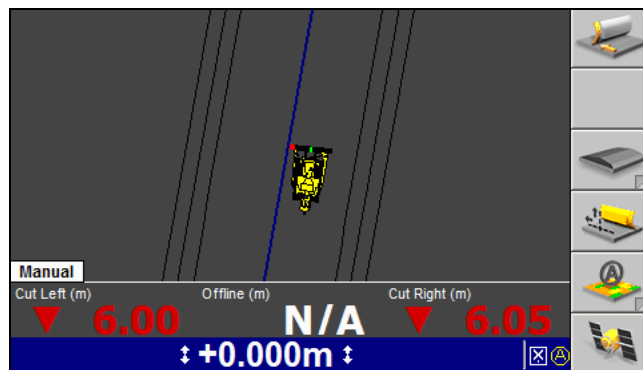

### 3.3 Warnings and other messages

The system provides the following messages:

- Full screen warnings
- Flashing warnings
- Messages from the site office

#### 3.3.1 Full screen warnings

Full screen warnings ask the operator to decide whether to continue working or not. The system does not provide lightbar guidance and automatic controls under these conditions.

The following figure shows an example of a full screen warning.

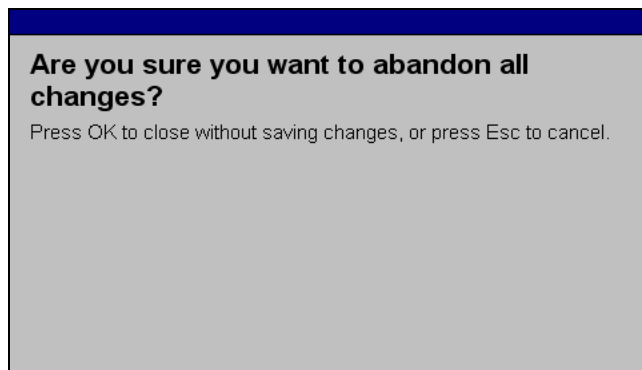

This warning appears when you have made changes to a dialog setting, but pressed  to exit the dialog.

#### 3.3.2 Flashing warnings

When an error occurs a warning message flashes on the screen every few seconds. The system provides neither lightbar guidance nor automatic controls under these conditions.

The following figure shows an example of a flashing warning message.

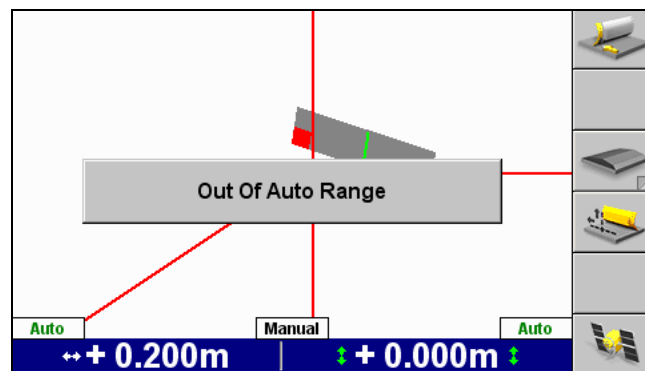

This warning appears when the cutting edge is too far from a 3D design for automatic controls to be used.

### 3.3.3 Messages from the site office

Office staff are able to transmit wireless data messages to a selected machine which has 900 MHz wireless communications.

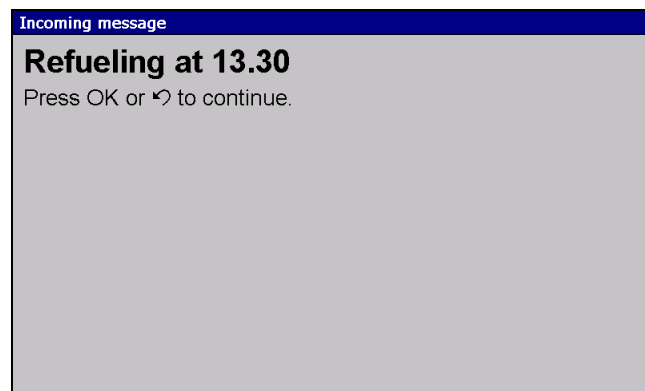

You must acknowledge messages from the office before you can continue working. To do this, press one of the following keys:

- 
- 

The message clears from the display, and the system tells the office which key you pressed.

## 3.4 Wireless communications with the office

An engineer or site supervisor can use an SNR9xx radio-modem to transfer data between the control box and the site office, including:

- 3D design files
- System diagnostic reports
- Messages from the site office
- Control box button presses

Data transfers take between a few seconds and a few minutes, depending on the amount of data being transmitted.

Typically, you will not notice that the transfer is taking place unless one of the following occurs:

- The office sends you a message. You must acknowledge messages from the office. For more information, see [3.3.3 Messages from the site office](#).
- The office is transferring a file to or from your system, and you try to load a design file. You are not able to load a design file while a file is transferring.

For more information, refer to the *GCS900 Grade Control System Site Supervisor's Manual*.

## 3.5 Machine configuration files

The site supervisor can save information about specific machines to a USB flash drive. This information is held in a machine settings file, and includes the:

- machine type
- machine dimensions
- sensors installed on the machine

If you share the control box between several machines, you can use the machine settings file to configure the system for a specific machine. Be sure to restore the correct machine settings file for your machine.

**Note** – *When you restore machine settings, the GNSS receiver configuration settings do not change, and AS400 angle sensor and RS400 rotation sensor calibration settings are not restored.*

## 3.6 Control box settings files

The site supervisor can save information about the guidance methods and configuration dialogs that the operator can access, to a USB flash drive. This information is held in a display settings file, which includes:

- the text items that display in the guidance screens
- configuration tasks that can be performed
- guidance settings that can be changed

You can use the display settings file to configure the control box for a specific operator, if the machine is being used by several operators.

*Note* – When you restore machine settings, the control box brightness setting does not change.

## 3.7 Diagnostics text file

The operator or site supervisor can take a zsnap to aid with troubleshooting. A zsnap takes a snapshot of the system (hold down  and press the fourth softkey from the top).

The software creates:

- a “snapshot” of the current system state and saves it as a .zsnap file
- a bitmap file of the current display and saves it as a .gif file
- a diagnostic text file of the current system configuration and saves it as a .diag.txt file.

All three files are saved in the root directory of the system and the names of the files indicate the date and time that the files were created.

The diagnostics.txt file can be used to provide information about the system configuration and components, and to diagnose systems issues. It contains information such as:

- System information
- Software options
- Machine information
- Machine status
- Operating hours
- Device descriptors

- Sensor diagnostics
- Mast measureup
- Blade dimensions
- Machine measureup
- Valve calibration table
- Coordinates of blade tip with focus
- Radio settings
- GNSS diagnostics



## Sensors

### In this chapter:

- Introduction
- 3D sensors
- Angle sensors
- Lift sensors
- RS400 rotation sensor
- Sensor groups
- HS410 heading sensor
- Cat PSC system
- SR300 survey laser receiver

This chapter describes the sensors used in the system and the sensors' operating limits.

## 4.1 Introduction

Each type of sensor used in the system has operating restrictions that limit that sensor's working range of distances or angles.

## 4.2 3D sensors

3D sensors are used, alone or in conjunction with other sensors, to calculate the position of the cutting edge in three dimensional space.

*Note – If GNSS Receiver Support is installed and enabled on a 2D Excavator system, the MS9x2 receiver is used in conjunction with other sensors, to calculate the position of the bucket **relative** to the benched point.*

The system supports two types of 3D sensors:

- GNSS receivers
- Universal Total Stations (UTS)

### 4.2.1 GNSS receivers

Systems that use GNSS receivers can provide precision guidance to both ends of the blade or bucket under a wide range of physical conditions, and over very large sites.

All Trimble GNSS receivers can receive signals from the Global Positioning System (GPS) satellites operated by the United States Department of Defense.

More advanced receivers can also receive signals from the following GNSS constellations:

- Global Positioning Satellite System (GLONASS) satellites, operated by the Russian Department of Defense
- Galileo Satellite System, operated by the European Space Agency
- BeiDou Navigation Satellite System (BDS) satellites, operated by the Chinese National Space Administration
- Quasi-Zenith Satellite System (QZSS) satellites, operated by the Japanese Satellite Positioning Research and Application Center

## Supported GNSS receivers

The following table lists supported GNSS receivers:

Receiver model	Mounting	Antenna
MS952	Cab or Blade	Internal
MS972	Cab or Blade	Internal
MS992	Cab or Blade	Internal

The constellation(s) and tracked signals a GNSS receiver can follow are controlled by option keys. The following table lists the supported constellations that are available:

Constellation	Tracked signal
GPS	GPS: L1 C/A, L2C, L5C
or	
GPS +:	
• GLONASS	GLONASS: G1 C/A, G1P, G2 C/A, G2P
and/or	
• Galileo	Galileo: L1 CBOC, E5A, E5B, E5AltBOC
and/or	
• BeiDou	BeiDou: B1, B2, B3
and/or	
• QZSS	QZSS: L1 C/A, L1C, L2CM, L2CL, L5 I, L5 Q, LEX, SAIF

**Note** – The tracked signals listed in the table above are available on a Triple frequency band. Single and Dual frequency bands do not offer the same amount of tracked signals. For more information, contact your dealer.

## How GNSS works

A GNSS receiver using RTK corrections combines the “time of flight” of radio signals broadcast from earth orbiting satellites with the precise position of each satellite when a radio signal was sent, to calculate the position of the receiver.

The main parts of a typical RTK GNSS system are:

- A source of real-time kinematic (RTK) corrections. RTK correction data enables the rovers to correct their GNSS measurements, and calculate highly accurate positions. The system supports the following sources of RTK

corrections:

- A conventional GNSS base station.  
This is a high accuracy GNSS receiver located at a fixed, known position. The base station calculates and transmits RTK corrections to one or more machine-based GNSS systems (rovers) working in the base's area.
- A Wi-Fi local base station.  
An SPS985 GNSS Smart Antenna with Wi-Fi communications can be used as a local base station. It will automatically establish a Wi-Fi connection with the rover(s) and transmit RTK corrections to it.
- Trimble VRS™ Global Navigation Satellite System (GNSS) infrastructure network technology.  
VRS is a network RTK system that creates a virtual reference station in the rover's area. The VRS service calculates RTK corrections based on the machine's uncorrected position, and transmits them to subscribers over the Internet.
- Internet Base Station Service (IBSS).  
IBSS provides GNSS correction information over the Internet using cellular services. This extends the range of base station correction sources. IBSS is delivered through the Connected Community website. See [2.4.3 Connected Community](#).
- A wireless data link to transmit corrections to the rover. The system supports the following wireless links:
  - Radio modems.  
Two radio modems, one at the base station (the base radio) and one on the machine (the rover radio) create the link. The link carries the RTK corrections from the base station to the GNSS receivers on the machine.
  - A cellular modem.  
The machine's cellular modem creates a link to the VRS service provider or the IBSS (through the Connected Community) over the Internet. The link carries RTK corrections from the VRS service or IBSS to the GNSS receivers on the machine.
- One or two GNSS receivers mounted on the machine.

To learn more about VRS or IBSS, contact your dealer.

*Note* – Only MS97x and MS99x receivers running firmware version 3.9x or later can use VRS corrections.

The following figure shows a dual GNSS system on a motor grader.



❶ GNSS receiver

Figure 4.1 Dual-GNSS system on a motor grader

In order to calculate an initial RTK position, a GNSS receiver must receive signals from at least five satellites. Once it has calculated an initial position, a GNSS receiver must continuously see at least four satellites. In addition, RTK corrections are calculated for individual satellites, and can only be used by the rover system to correct its measurements of the same satellites. For this reason, both the base station, or virtual reference station, and the rover receiver must use satellites common to both to calculate their positions.

### GNSS quality

The signals received by the GNSS receivers are very low power and although the signals pass freely through clouds and dust, the signals are disrupted by foliage, or structures like bridges and overpasses. Disruptions may also occur when the machine moves out of sight of one or more satellites, or when one or more satellites moves out of sight of the machine, or by “setting” below the horizon.

Because of the possibility of disruption, you should pay attention to the quality of the GNSS position information you are receiving, and make sure it is suitable for the type of work you are doing.

### GNSS accuracy levels

If you use one or more GNSS receivers, then the system will continually generate estimates of the GNSS position error.

You can set the maximum value of the GNSS error estimate that is acceptable for your application. If the GNSS error estimate exceeds the value you define, a **Low Accuracy (GNSS)** message appears.

There are three GNSS accuracy levels, or modes:

- Fine
- Medium
- Coarse (default for SBAS)

The limit for each mode is set to suit the type of work. For example, the limits for Fine mode are set for finish trim work. If the GNSS accuracy is not within the tolerance set for Fine mode, do not change into Coarse mode to continue work on the final trim surface. Instead, do one of the following:

- Wait for the GNSS accuracy to improve and then continue in Fine mode.
- Change the GNSS accuracy mode and then continue working on an area that does not require Fine mode GNSS accuracy.
- Change the GNSS accuracy mode and then raise the vertical offset to leave the constructed surface high. Return to the area when the GNSS accuracy has improved and allows Fine mode operation. This enables you to continue working on the same area of the design and not overcut the final design surface.

The GNSS accuracy mode setting also determines what GNSS accuracy is required before automatic controls can be activated. The *GNSS Accuracy Mode* dialog displays a *Yes* in the *Auto* column if controls are available.

Use the text items listed below to display the current GNSS accuracy level:

- *H. GNSS Err.* – GNSS horizontal error
- *V. GNSS Err.* – GNSS vertical error
- *GNSS Acc. Mode* – current GNSS accuracy mode setting

The color of the text item shows whether the current GNSS error is within the selected GNSS accuracy mode limits:

- The text item value remains black while the GNSS error is less than 90% of the limit defined for the GNSS accuracy mode.
- When the GNSS error is approaching the defined limit, the text is blue.

- If the GNSS error exceeds the limit of the GNSS accuracy mode, the text is red.

For more information, refer to the *GCS900 Grade Control System Site Supervisor's Manual*.

### Sky Plot

The *Sky Plot* dialog provides real-time GNSS satellite position information. You can use this information to diagnose GNSS problems that the current satellite constellation may cause.

### GNSS position error

The accuracy of a GNSS position can vary. Although an RTK position is normally accurate enough for construction work, this is not always the case.

When you place a GNSS receiver in a stationary position and monitor the position output, there are small changes (errors) in the position. The position change is caused by 'noise' in the solution. The GNSS position error is an estimate of the amount of noise in the GNSS positions.

The GNSS receiver estimates errors for every GNSS position. There are two horizontal errors and one vertical error. The two horizontal errors describe an ellipse in a horizontal plane. The vertical error projects this ellipse above and below the horizontal plane.

The following figure shows the GNSS error volume.

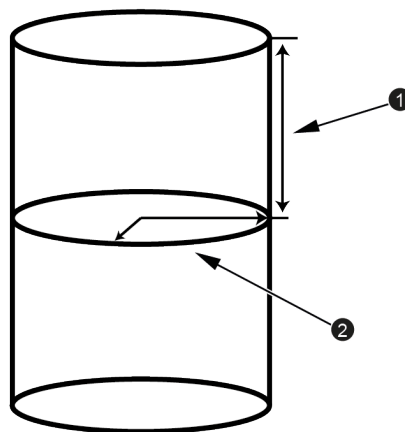

① 1 sigma vertical error

② 1 sigma horizontal error ellipse

Figure 4.2 GNSS horizontal and vertical error

Because the errors are estimates, the value of the error is associated with a probability of the estimate being accurate. There is a 1 sigma (approximately 64%) probability that the true position will lie within the horizontal and vertical errors reported by a GNSS receiver.

The calculated elevation is less accurate than the calculated Northings and Eastings. This is because the elevation is calculated in relation to the height above sea level, which is estimated using the geoid model and the site calibration.

For dual GNSS systems, the left and right receiver positions are reported independently. Guidance is only given when the error for the left receiver position and the error for the right receiver position are within the GNSS error limits set for the GNSS accuracy mode.

### Coordinate systems

Coordinate systems transform spherical coordinates (positions in terms of latitude and longitude) into the plane-rectangular coordinates (positions in terms of Northings and Eastings or Southings and Westings) used in ordinary plane surveying.

The coordinate transformation is called a projection. Different projection methods introduce different types and magnitudes of distortions.

Coordinate systems that the GCS900 Grade Control System supports are:

- SnakeGrid coordinate system

SnakeGrid is a coordinate system with minimal scale factor and height distortion at the centerline of a project, even when projects extend for many hundreds of kilometers. A job using a SnakeGrid coordinate system must use a custom SnakeGrid parameter file. These files are obtained through a licensing arrangement from the UCL Department of Civil, Environmental and Geomatic Engineering. Each SnakeGrid parameter file is customized for a specific project alignment envelope. For more information on SnakeGrids, refer to [www.SnakeGrid.org](http://www.SnakeGrid.org).

- South azimuth coordinate systems

South azimuth coordinate systems take due South as the origin for azimuth measurements. The GCS900 Grade Control System only supports South azimuth coordinate systems where the coordinates increase in the South and West directions.

### Coordinate adjustments

Coordinate adjustments are used to modify the results of an initial projection. The adjustments are typically used to modify global coordinates to achieve a best fit with regional coordinates.



The adjustments supported by GCS900 Grade Control System are:

- latitude/longitude adjustments using datum grids
- plane-rectangular coordinate adjustments using shift grids
- elevation adjustments using geoid grids

Grid	Description
Datum grids	<p>GNSS measurements of latitude and longitude are referenced to the 1984 World Geodetic System reference ellipsoid, known as WGS84. Because of errors in WGS84, localized ellipsoids have been derived to best represent the latitude and longitude in specific areas. These ellipsoids are sometimes referred to as local datums.</p> <p>Before local coordinates can be calculated, the WGS84 GNSS latitude and longitude must be transformed into the local latitude and longitude using a datum transformation performed by a datum grid. A datum grid uses a gridded data set of standard datum shifts. By interpolation, it provides an estimated value for a datum transformation at any point on that grid.</p>
Shift grids	<p>Shift grid corrections are generally used to fit the initial projection coordinates to local distortions in the survey framework. You can apply a shift grid to any type of projection definition. Some countries use shift grids to apply corrections to initial coordinates. Coordinate systems that use shift grids include the Netherlands RD zone, and the United Kingdom OS National Grid zones.</p>
Geoid grids	<p>The reference ellipsoid is the surface used to calculate the GNSS height value. The geoid is a surface of constant gravitational potential that approximates mean sea level around the globe. A geoid grid (or geoid model) is a table of geoid-ellipsoid separations that is used with the GNSS ellipsoid height observations to provide a more accurate estimate of elevation.</p>

### Choosing a coordinate system

Every design that could be used with a GNSS-based system must have a coordinate system associated with it. The coordinate system is in the form of a file stored in the design folder.

In most cases, the coordinate system is created in the office when the design is created.

However, for designs and maps that are created in the field, the operator must choose the design's coordinate system from one of the following:

- the last coordinate system loaded onto the GNSS receivers
- a new coordinate system automatically generated for their current location (MS9x2-based systems only)
- a coordinate system stored in the root directory of the control box's file system

The benefits of in-field designs having a known coordinate system include:

- You can ensure that the coordinate system used is appropriate for the site. This keeps your horizontal and vertical positions consistent for each site. In addition, all the machines working on a site use the same coordinate system for their in-field designs.
- The operator has more information about the coordinate system they are using when they create a design in the field.
- If your system uses MS9x2 GNSS receivers, the ability to create a new coordinate system based on your current position is useful for users that are on a site with no currently established coordinate system.

### Automatic coordinate system generation with MS9x2 GNSS receivers

When using MS9x2 GNSS receivers, the system has the ability to create its own coordinate system, using its current location to select from a library of pre-calculated coordinate systems.

This allows users to get up and running without needing a site calibration. This is useful for machines such as compactors where basic pass count information is required. Similarly, automatically generated coordinate systems are useful for jobs where positions are relative to the current base station position, or where designs created in the field are commonly used.

The system also uses an embedded Geoid stored in the MS9x2 receiver, to ensure that elevations are based on Geoid heights, even when you are not using an externally based site calibration and coordinate system.



---

ATTENTION - When the system is using an automatically created coordinate system, it will not let the system run with site wide avoidance zones or site wide background line work files as these are based on a specific coordinate system, not the automatically generated coordinate system.

---

### GNSS receiver configuration files

There are two types of GNSS receiver configuration files that can be used:

- A \*.cfg file (GNSS receiver configuration file)  
A \*.cfg file is needed for use with MS990 receivers or MS9x2 receivers that do not have firmware v4.89 or later.  
*Note – A \*.cfg file does not support any of the grid files listed in [Table 4.1](#).*
- A \*.cal file (GNSS receiver coordinate system file)  
A \*.cal file can reference a full geoid grid file or additional coordinate adjustment grid files, see [Table 4.1](#).

**Note** – An MS9x2 receiver with firmware v4.89 or later is needed for use with a \*.cal file.

GNSS receiver configuration files can be created in a number of ways:

- If a site calibration is performed, it can be converted to a GNSS receiver configuration file, refer to the *GCS900 Grade Control System Site Supervisor's Manual*.
- If an operator creates a level, sloping or map design with a GNSS system a configuration file is created and stored in the \<design> folder on the control box.

The type of configuration file created depends on the file in use at the time. For example; if a \*.cal file is in use when the level, sloping or map design is created then it will be created with a \*.cal coordinate system file.

- The Trimble Business Center – HCE or Trimble SCS900 software packages can export GNSS receiver configuration files.

When exporting to Machine Job Site Design Exporter in Business Center – HCE, if one of the adjustment grids in [Table 4.1](#) is not used, Business Center – HCE creates a \*.cfg file and an empty \*.cal file. If one of the adjustment grids is used, Business Center – HCE only creates a \*.cal file.

**Note** – The 'Controller Software Version' is set to '12.6', with 'EnableMS990 Compatibility' set to 'No'.



**Tip** – \*.dc files can be renamed to have the \*.cal extension.

The GNSS receiver configuration files may be stored in either the "Machine Control Data\<Machine Name>" and/or "Machine Control Data\<Machine Name>\<design>" directories on the control box. Each \<design> folder can contain a \*.cfg file and/or a \*.cal file. The \*.cal file can be used to identify entities in the \GeoData folder, if they are present. If both a \*.cfg file and a \*.cal file (with the same name) are found in the \<design> directory, only the \*.cfg file is used.

The \GeoData folder is located in the "Machine Control Data\<Machine Name>" directory on the control box. The files it contains can be added to via the "Machine Control Data\All\GeoData" or "Machine Control Data\<Machine Name>\GeoData" directory of a USB drive or via the "\<Machine Name>\ Machine Control Data\GeoData" directory on the Connected Community.

The \GeoData folder can contain the following files:

**Table 4.1 — The \GeoData folder**

File	Description
current.csd	Coordinate system dictionary file
*.ggf	Geoid grid file

File	Description
*.dgm	Datum grid file
*.sgf	Shift grid file
*.dat	SnakeGrid file

For more information on the grid files in the \GeoData folder, see [Coordinate adjustments](#).

The \*.cal or \*.cfg file is sent to the GNSS receiver(s) after a design is successfully loaded on the control box.

Because GNSS receiver configuration files are stored in the control box rather than in the GNSS receiver, you will need to update them each time you change site. For more information, refer to the *GCS900 Grade Control System Site Supervisor's Manual*.

#### 4.2.2 Trimble UTS robotic total station

A single UTS system, used with a cross slope group of sensors, can provide high precision 3D guidance to both cutting edge tips. A UTS system is able to provide higher accuracy positioning than GNSS, and can continue to work in circumstances that would usually degrade GNSS performance.

There are three main parts to a UTS system:

- A target. The target is mounted on a mast located on the part of the machine for which you need position information. Typically this will be a point at the center, or near one end, of the blade. The target has two sections:
  - An LED unit, which acts as the target for the tracking system
  - A prism unit, which acts as a target for the electronic distance measuring (EDM) system
- A UTS instrument. The UTS is a robotic total station capable of making high precision measurements of the horizontal and vertical angles, and slope distance to the target. Specially designed servo-motors work with the tracking software to allow the UTS to track targets moving at typical machine speeds. If the target is lost, then the UTS will try to predict how the target is moving, so that it can attempt to reacquire the target.
- A data radio link. The data radio link consists of two data radios, one at the UTS, and one on the machine. The link carries the position of the target, as measured by the UTS, back to the system on the machine. The system combines the position of the target, relative to the UTS, with the known position of the UTS, to generate 3D target positions.

The link also enables the system to send commands back to the UTS.

The following figure shows the two main components of a UTS system; the target and the UTS instrument.

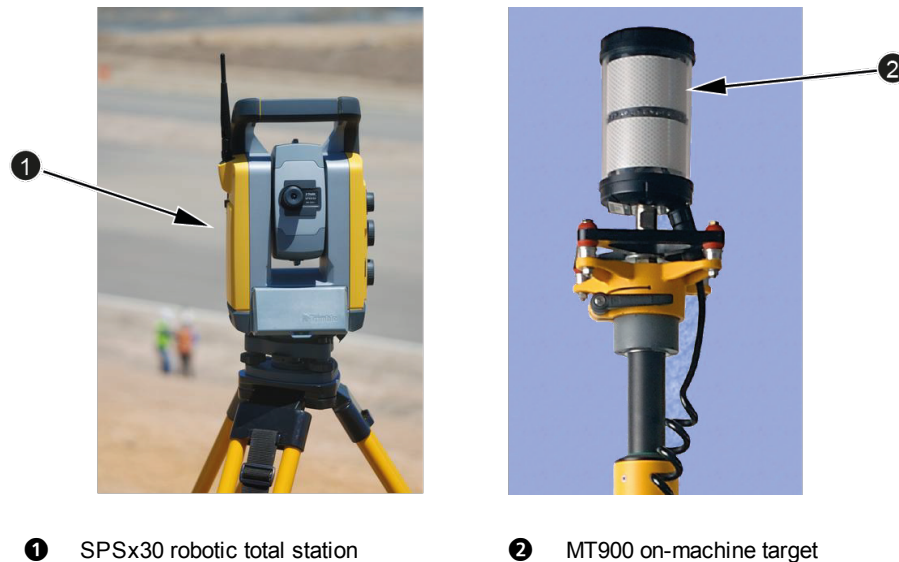

❶ SPSx30 robotic total station

❷ MT900 on-machine target

Figure 4.3 UTS system - SPSx30 instrument and MT900 target

**Note** – The MT900 target only operates with the SPSx30 instrument.

Each time you set up a UTS system, and before you can begin work with it, you must perform the following tasks:

1. Establish the location of the UTS, and orient the UTS' coordinate system.
2. Establish the search area of the target, relative to the UTS.
3. Establish the radio link between the UTS and the system.
4. If the location of the UTS is only known in terms of easting and northing (two dimensional) coordinates, establish the elevation of the target by benching.

In order to track the target reliably over a wide range of machine operating speeds, the UTS should not be closer than 15 meters (50 feet) to the machine, nor farther than 300 meters (985 feet) from the machine.

You must position the UTS so that it is free from vibration due to wind or vehicle movements, and has a clear line of sight to the target over the full work area.

## 4.3 Angle sensors

Angle, or slope, sensors measure the attitude of a machine's structure relative to gravity.

### 4.3.1 AS400 slope sensor

The AS400 slope sensor is a rugged, single-axis attitude sensor.

Single 3D-sensor dozer, motor grader, and single GNSS scraper systems use an AS400 slope sensor to measure blade slope. The AS400 slope sensor can also be used to measure the mainfall of a dozer or a motor grader.

The following figure shows the AS400 on the blade of a dozer.



You can use the AS400 slope sensor over a range of  $\pm 45^\circ$ .

### 4.3.2 AS450, LC450 and AS456 angle sensors

The AS450, LC450 and AS456 angle sensors are rugged, single-axis attitude sensors that measure the following excavator arm data:

- Boom angle
- Stick angle
- Bucket curl
- Bucket tilt

This information is used in calculating the position of the cutting edge of the bucket.

The following figure shows the different angle sensor applications.

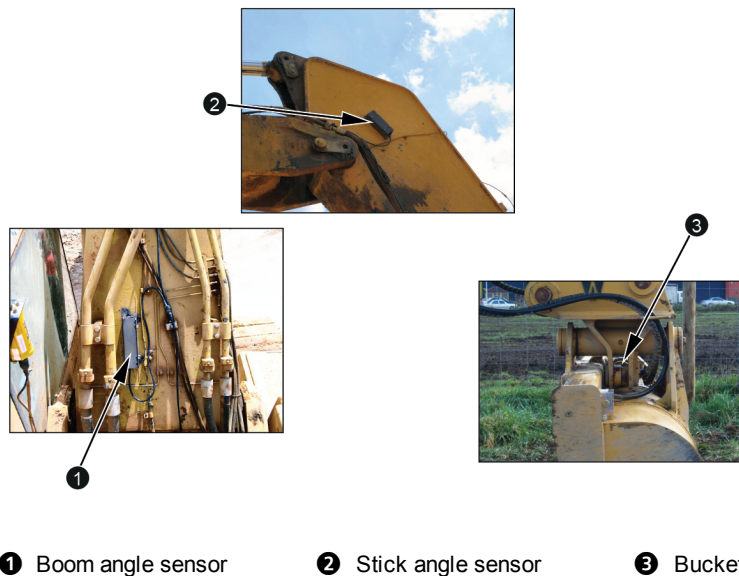

❶ Boom angle sensor

❷ Stick angle sensor

❸ Bucket tilt sensor

Figure 4.4 Excavator arm angle sensors

The AS450, LC450 and AS456 angle sensors can operate over a range of  $\pm 180^\circ$ .

The response time of an angle sensor limits guidance accuracy in the following two ways:

- The vertical (cut/fill) guidance accuracy is affected by rapid movements of the arm. It is recommended that you use a stationary bucket to regularly check the grade of the surface being worked, to ensure that you are working to the correct elevation.
- The bucket tilt guidance accuracy is affected by rapid rotation. Only change the bucket tilt when the machine is not rotating.

The AS456 angle sensor is specifically designed for mounting on excavator tiltrotator mechanisms such as the Indexator Rototilt RT40, RT60 and RT80 bucket attachments. The rotation of the bucket is not measured and all guidance calculations assume the bucket is perpendicular to the long axis of the arm.

**Note** – The AS456 is supported by any version of the system that supports AS450s.

The following figure shows an AS456 submersible angle sensor.



---

ATTENTION - The use of a standard bracket for an angle sensor on the bucket linkage of an excavator limits the operating depth of the system to less than 1 m, when the system is used to provide bucket guidance under water. This depth can be extended to 20 m with the use of a deep water housing (PN 74706-18).

---

Depth and Slope excavator systems can use the LC450 laser catcher to measure the elevation reference from a laser transmitter.

The laser catchers have a laser window that detects the laser beam and sends information about its elevation to the system.

Laser catchers are typically mounted on the excavator stick. The following figure shows an LC450 laser catcher.





#### 4.3.3 AS460 dual axis sensor

The AS460 dual axis sensor measures both the pitch and roll of an excavator's body. The following figure shows an AS460 angle sensor.



The AS460 dual axis sensor can operate over a range of  $\pm 45^\circ$  for both axis.

#### 4.3.4 GS420 inertial sensor

*Note – The GS420 can only be used as a blade slope sensor on dozers.*

The Trimble GS420 Inertial Sensor is a machine sensor for measuring acceleration and rotation in 3 dimensions. The GS420 is designed for durability in harsh environments and is suitable for external mounting directly on machine linkages.

*Note – The GS420 does not support a mainfall sensor and cannot estimate "blade-on-ground" for mapping purposes.*

*Note – The GS420 does not support a blade rotation sensor and cannot calculate cross-fall for conventional and single-sensor 3D systems.*

The following figure shows a GS420 inertial sensor.



Measurement	Range	Resolution
2-axis inclination	±45°	0.01°
3-axis rotation rate	±250°/s	±10°/s
3-axis acceleration	±13g	0.01m/s <sup>2</sup>



**ATTENTION** – You must not install a mix of AS400 Angles Sensors and GS420 Inertial Sensors on the same machine.

## 4.4 Lift sensors

Lift sensors measure the height of the cutting edge relative to an external reference such as a laser plane or an existing curb.

### 4.4.1 LR410 laser receiver

The LR410 laser receiver is a rugged laser detector designed specifically for machine control.

You can use one or two laser receivers with the system. An LR410 laser receiver is almost always used in conjunction with an electric mast. A laser receiver must be benched before use.

The following figure shows the LR410 laser receiver on an electric mast.



The following table lists the operating limits of the LR410 laser receiver:

Sensor	Guidance band	Offset range
LR410 laser receiver - fixed mast	± 100 mm	± 100 mm (see 1 below)
LR410 laser receiver - EM400 mast	± 100 mm	± 500 mm (see 2 below)

1 This value assumes that the laser strike was in the center of the laser receiver's detector when the blade was benched on the design surface.

2 This value assumes that the laser strike was in the center of the laser receiver's detector, and the mast was at half its maximum extension when the blade was benched on the design surface.

#### 4.4.2 ST400 sonic tracer

The ST400 sonic tracer is a rugged, temperature-compensated, non-contact, distance measuring device that uses the “time of flight” of a burst of ultrasonic sound to determine the distance to a target surface. Suitable target surfaces include string lines, existing curbs, and previously graded surfaces.

You can add one or two sonic tracers to the system at any time, and with a minimum of system configuration.

*Note – Sonic tracers can be used with motor graders and dozers.*

You must bench the sonic tracer before use.

The following figure shows the ST400 sonic tracer on the blade of a motor grader tracking a string line.



Target reference surfaces need to be relatively smooth. For example, the top course of a chip sealed road would be a suitable reference surface. A previously graded surface, crossed by motor grader tire tracks would probably be an unsuitable reference surface.

To enable a sonic tracer to operate in situations where it receives reflected signals from both the reference, for example a string line, and another surface, for example the ground below the string line, once the tracer is benched it must remain within a certain distance of the benched elevation. This range is called the “sonic gate”.

The following table lists the operating ranges and sonic gates for supported sonic tracers:

Type	Range (string line)	Range (reference surface)	Sonic gate
ST400	200 mm – 900 mm	200 mm – 1300 mm	± 70 mm
	8 inches – 36 inches	8 inches – 51 inches	± 2.8 inches

## 4.5 RS400 rotation sensor

The RS400 rotation sensor is a rugged sensor that measures the rotation of the blade. On a motor grader system, the RS400 is typically mounted on the hydraulically swivel of the motor grader’s circle; the mounting location for a dozer system is machine-dependent.

The following figure shows the RS400 rotation sensor mounted on a motor grader.



You can use the RS400 rotation sensor over a range of  $\pm 160^\circ$ .

## 4.6 Sensor groups

A sensor group is a set of sensors, the outputs of which are combined to produce a single, "complex" value.

The system supports two sensor groups:

- the cross-slope sensor group
- the "blade-on-ground" sensor group

### 4.6.1 Cross slope sensor group

The cross slope sensor group generates information that enables the system to calculate the slope of the blade perpendicular to the direction of travel of the machine, allowing for the mainfall of the machine, and the blade's slope and rotation. This projected blade slope is called the cross slope. The cross slope sensor group for a motor grader or dozer system consists of three sensors of two different types:

- Two AS400 angle sensors
  - One is used to measure the slope of the blade, and is typically mounted on the back of the blade of a dozer, or on the rear of the circle of a motor grader
  - The other is used to measure the mainfall of the machine, and is typically mounted on the body of a dozer, or on the gooseneck of a motor grader
- An RS400 rotation sensor to measure blade rotation

### 4.6.2 The "Blade-on-Ground" sensor group

The "Blade-on-Ground" sensor group generates information that enables the system to measure the elevation of the blade relative to the body of the machine, and to estimate if the blade is at, or below, ground level and so moving dirt. This feature can be used for automatic mapping in dozers and motor graders. In addition, this feature allows more useful productivity data to be recorded. The "Blade-on-Ground" sensor group for grader and dozer systems consists of two sensors:

- An AS400 angle sensor to measure the angle of the push arms or C-frame of a dozer, or the angle of the A-frame of a motor grader
- An AS400 angle sensor to measure the mainfall (pitch) of the machine.  
Typically mounted:
  - on the gooseneck of a motor grader
  - on the body of a dozer

*Note* – It is possible to use an existing blade pitch sensor as the push arm or C-frame angle sensor; however, this is not recommended, as inadvertent pitching of the blade reduces the accuracy of the "Blade-on-Ground" estimation.

*Note* – When using "Blade-on-Ground" on a dual GNSS motor grader, using circle shift will produce inaccurate "Blade-on-Ground" estimation.

## 4.7 HS410 heading sensor

The HS410 heading sensor is designed to measure changes in orientation relative to the Earth's magnetic field.

The system uses a heading sensor to measure cab rotation in conventional (2D) excavator systems, and the sensor is commonly referred to as a cab rotation sensor. Combining cab rotation measurements and body pitch/roll measurements allows the system to provide the operator with precise bucket guidance, even when the machine is rotated away from the bench orientation while working on slopes. In addition, the usability and flexibility of the laser benching and Touch Point features are greatly enhanced.

The following figure shows an HS410 heading sensor mounted on the counterweight of an excavator.



The following table lists the physical and electrical characteristics of the HS410 heading sensor.

**Table 4.2 — HS410 physical and electrical characteristics**

Item	Description
Dimensions	Width: 16.5 cm Length: 16.5 cm Height: 102 cm
Heading sensor range	360°
Operating temperature	-20°C to +50°C (-4°F to +122°F) upper limit for full specified accuracy
Operating voltage	9 to 32 VDC
Power consumption	1.2 A max. (during warm-up), < 0.3 A (operating)
Housing	Aircraft grade aluminum alloy with minimal amount of iron content
Communications link	CAN (Controller Area Network)

## 4.8 Cat PSC system

The Cat PSC system is only available for excavators fitted with the Cat Generation 2 Excavator Attachment Ready Option. The Cat PSC system replaces the boom, stick and bucket angle sensors with:

- Two potentiometers:
  - A potentiometer located on the boom stick pin that measures the angle between the boom and the stick.
  - A potentiometer located on the boom pin that measures the angle between the body of the machine and the boom.
- A position sensing cylinder (PSC) located in the bucket ram hydraulic. The PSC measures the extension of the hydraulic ram.



The system uses the measurements from these devices to calculate the position of the bucket in relation to the body of the machine.

## 4.9 SR300 survey laser receiver

The SR300 survey laser receiver most provides high precision elevation data to 3D guidance systems. You can also use a survey laser receiver for conventional guidance.

The following figure shows the SR300 survey laser receiver.



The SR300 survey laser receiver uses a linear array of photo detectors to detect a laser plane generated by a laser transmitter.

The survey laser receiver is able to detect the height of the laser plane with a resolution of  $\pm 0.1$  mm ( $\pm 0.004$  inch), within a  $\pm 1.0$  mm dead band, for elevation changes of up to 1 m (39 inches).

The SR300 survey laser receiver operates under the following limits:

- Maximum detection range of 500 m (1500 ft) with suitable laser transmitters.
- Maximum vertical slew rate of 430 mm/s (17 inches per second).
- Maximum deviation from vertical in any plane of  $10^\circ$ .
- For conventional systems, once a survey laser receiver has been benched, the laser strike must remain within  $\pm 10$  cm (4 inches) of the bench position. If the



system is in Auto mode, the Increment/Decrement offset switches moves the bench window as the offset is increased or decreased.

- If more than one laser transmitter is visible from a working machine, then the laser planes must be at least 10 cm (4 inches) apart in elevation to be distinguished as coming from separate laser transmitters.

The laser receiver can only be in the on or off states. When the laser receiver is on, the elevations from the laser receiver are used for vertical guidance, and the elevations from the GNSS receiver are used to verify the laser's results. When the laser is off, the elevations from GNSS are used for vertical guidance.

To maintain accurate information from a laser transmitter:

- Do **not** operate lasers at dawn or dusk, or when conditions are foggy or raining.
- Make sure that the laser transmitter is regularly serviced and in good operating order.

*Note – Unlike conventional laser-based machine control, the laser plane is set up for 3D guidance to maximize laser coverage and reception. The laser plane does not define the grades of the 3D design surface.*



## Wireless Radios

### In this chapter:

- Introduction
- Broadcast Radio Modems
- Cellular modems
- Wi-Fi networking

This chapter describes the various devices the system can use to transfer data wirelessly.

## 5.1 Introduction

The system supports the following methods for wireless data transfer:

- Broadcast Radio Modems
- Cellular modems
- Wi-Fi networking

## 5.2 Broadcast Radio Modems

The GCS900 Grade Control System supports the following broadcast radio modems:

- SNRx10 multi-band radio modems
- SNRx20 multi-band radio modems

### 5.2.1 SNRx10 multi-band radio modems

The SNRxxx radio modem is a rugged on-machine radio modem used to receive data (corrections) from a GNSS reference station, or position information from a UTS system. In addition, if a 900 MHz module is installed in the radio, two-way data can be exchanged with a base radio.

The following figure shows an SNRxxx mounted on the cab of a machine.



The SNRxxx data radio accepts three different radio modules. Each module operates in a frequency band commonly used for machine control and guidance. The data radio can accept two modules at a time. Only one module at a time can transmit and receive.

The table below describes each radio module and its features.

**Table 5.1 — Wireless SNRxxx Modules**

Module	Description	Features
450 MHz data radio module	The 450 MHz data radio is a multi-channel, ultra high frequency (UHF) radio unit and data modem	<ul style="list-style-type: none"> <li>• Supports low latency CMRx transmission</li> <li>• Compatible with Trimble TRIMTALK 450 and TRIMMARK radios</li> <li>• Selectable frequencies and channels</li> <li>• Typical 3–5 kilometer range</li> </ul>
900 MHz data radio module	The 900 MHz data radio is a frequency-hopping, spread spectrum radio unit and data modem	<ul style="list-style-type: none"> <li>• Supports low latency CMRx transmission</li> <li>• Compatible with Trimble SiteNet™ and TRIMCOMM radio networks</li> <li>• Supports 40 selectable networks</li> <li>• License free operation in the United States, Canada, Australia and New Zealand</li> <li>• Typical 3–5 kilometer range</li> </ul>
2400 MHz data radio module	The 2400 MHz (2.4 GHz) data radio is a frequency-hopping, spread spectrum radio unit and data modem	<ul style="list-style-type: none"> <li>• Operates directly on 12 volt or 24 volt machine power</li> <li>• License free operation in the European Union, the United States, Canada, Australia and New Zealand</li> <li>• Compatible with Trimble total stations</li> <li>• Compatible with Trimble SPS882 GNSS base stations</li> <li>• Supports a high data rate</li> <li>• Has low power consumption</li> <li>• Typical &gt;1000 meter line of sight range</li> </ul>

Broadcast frequency, power transmission, channel spacing, and antenna gain are regulated by country and are generally unique on a per-country basis.

When you order a GCS900 Grade Control System SNRxxx data radio, you must specify the:

- broadcast frequencies
- channel spacing
- country of use

### 5.2.2 SNRx20 multi-band radio modems

The SNRx20 range of multi-band radio modems has the same physical size and mounting layout, and offers the same mix of frequency bands, as the SNRx10 radio modems. In addition, the SNRx20 radio modems support 802.11 b and 802.11 g wireless connectivity for Wi-Fi networking.

The SNRx20 radio modem can use Wi-Fi to connect to a wireless access point and create and maintain multiple Internet connections simultaneously. This means a single SNRx20 can, for example, connect to both the Connected Community and a VRS™ network RTK correction service at the same time.

**Note** – An SNRx20 radio cannot be used as a Wi-Fi local base station.

The following figure shows a configuration using the 2.4 GHz radio module (SPS985), the SNR2420 radio modem.

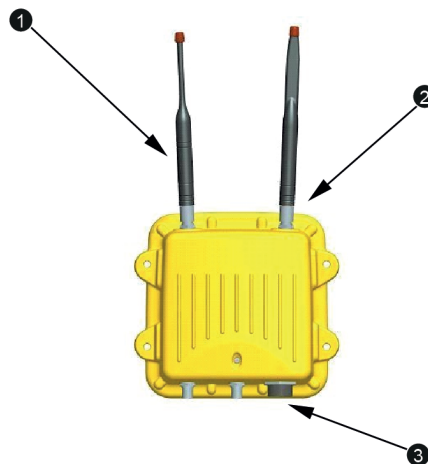

❶ 2.4 GHz antenna      ❷ Primary Wi-Fi antenna      ❸ Harness connector

Figure 5.1 SNR2420 radio modem

Some configurations allow you to connect a remote Wi-Fi antenna to supplement the antenna on the SNRx20 unit.

The following table lists the available SNRx20 radio modem base bands.

Name	Base band
SNR420	410 – 470 MHz
SNR920	900 MHz
SNR2420	2.4 GHz

All configurations are supplied with a Wi-Fi module. Both the SNR420 and SNR920 radio modems are available in configurations that include a 2.4 GHz module.

## 5.3 Cellular modems

A cellular modem is a wireless device that enables the on-machine system to connect to a computer network, such as the Internet, over a cell phone network.

The system uses a cellular modem to connect to, and exchange files with, the Connected Community website, and to receive Network RTK corrections.

### 5.3.1 The Trimble SNM940 Data Communications Module

The Trimble SNM940 Data Communications Module (DCM) is the recommended Wi-Fi/cellular device for on-machine systems. In addition to quad band GSM cellular modem functionality, the SNM940 DCM has advanced data logging capabilities and supports a number of local-area communications options.

Using the NTRIP communications protocol, an SNM940 DCM can create and maintain multiple Internet connections simultaneously. This means a single SNM940 DCM can, for example, connect to both the Connected Community and a VRS™ network RTK correction service.



The following table lists the physical and electrical characteristics of the SNM940 data communications module.

**Table 5.2 — SNM940 physical and electrical characteristics**

Item	Description
Dimensions	W: 230 mm (9.06 inch) X D: 120 mm (4.72 inch) X H: 40 mm (1.57 inch)
Operating temperature	-40°C (-40°F) — +75°C (+167°F)
Storage temperature	-40°C (-40°F) — +85°C (+185°F)
Protection rating	SAE J1455
Casing	Cast aluminum
Power consumption	Idle: <11 mA (at 12 V DC) Peak: 1.0 A (at 12 V DC)
Communications link	RS-232, 802.11b/g/h/e, USB 2.0, CANbus, SAE J1939, Ethernet 10/100 Base-T
Cellular modem serial communications protocol	IBSS/NTRIP

### 5.3.2 Third-party cellular modems

The system can also use third-party cellular modems that meet the following requirements:

- support for an RS-232-standard serial communications link
- support for the Client/Client (direct serial link) communication protocol

## 5.4 Wi-Fi networking

Wi-Fi networking is the common name for an Internet Protocol (IP) network using the IEEE 802.11 wireless networking protocol. This protocol manages two-way wireless IP data transfer between two or more wireless devices and, optionally, a wired networking infrastructure. Wi-Fi is intended for medium to high speed data transfer over short distances.

The 802.11 protocol allows for a number of different data transmission schemes. The Wi-Fi devices used in the GCS900 Grade Control System comply with the 802.11 b and g specification. These specifications are for devices transmitting in the S-Band Industrial, Scientific and Medical (ISM) frequency band, which operates in the frequency range of 2.4 to 2.5 GHz, and allows for bit rates of between 1 Mbps and 54 Mbps.

The GCS900 Grade Control System supports the following Wi-Fi devices:

- SNM940
- SNRx20



- Third-Party Wi-Fi devices

### 5.4.1 The Trimble SNM940 Data Communications Module

The Trimble SNM940 Data Communications Module (DCM) is the recommended Wi-Fi/cellular device for on-machine systems. In addition to quad band GSM cellular modem functionality, the SNM940 DCM has advanced data logging capabilities and supports a number of local-area communications options.

Using the NTRIP communications protocol, an SNM940 DCM can create and maintain multiple Internet connections simultaneously. This means a single SNM940 DCM can, for example, connect to both the Connected Community and a VRS™ network RTK correction service.



The following table lists the physical and electrical characteristics of the SNM940 data communications module.

**Table 5.3 — SNM940 physical and electrical characteristics**

Item	Description
Dimensions	W: 230 mm (9.06 inch) X D: 120 mm (4.72 inch) X H: 40 mm (1.57 inch)
Operating temperature	-40°C (-40°F) — +75°C (+167°F)
Storage temperature	-40°C (-40°F) — +85°C (+185°F)
Protection rating	SAE J1455
Casing	Cast aluminum
Power consumption	Idle: <11 mA (at 12 V DC) Peak: 1.0 A (at 12 V DC)
Communications link	RS-232, 802.11b/g/h/e, USB 2.0, CANbus, SAE J1939, Ethernet 10/100 Base-T
Cellular modem serial communications protocol	IBSS/NTRIP

### 5.4.2 SNRx20 multi-band radio modems

The SNRx20 range of multi-band radio modems has the same physical size and mounting layout, and offers the same mix of frequency bands, as the SNRx10 radio modems. In addition, the SNRx20 radio modems support 802.11 b and 802.11 g wireless connectivity for Wi-Fi networking.

The SNRx20 radio modem can use Wi-Fi to connect to a wireless access point and create and maintain multiple Internet connections simultaneously. This means a single SNRx20 can, for example, connect to both the Connected Community and a VRS™ network RTK correction service at the same time.

*Note – An SNRx20 radio cannot be used as a Wi-Fi local base station.*

The following figure shows a configuration using the 2.4 GHz radio module (SPS985), the SNR2420 radio modem.

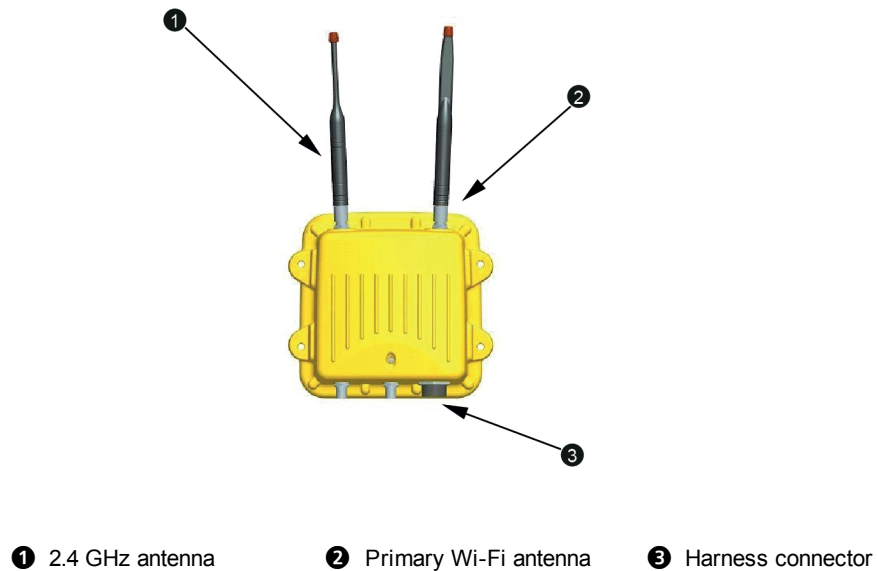

Figure 5.2 SNR2420 radio modem

Some configurations allow you to connect a remote Wi-Fi antenna to supplement the antenna on the SNRx20 unit.

The following table lists the available SNRx20 radio modem base bands.

Name	Base band
SNR420	410 – 470 MHz
SNR920	900 MHz
SNR2420	2.4 GHz

---

All configurations are supplied with a Wi-Fi module. Both the SNR420 and SNR920 radio modems are available in configurations that include a 2.4 GHz module.

### 5.4.3 Third-party wireless networking devices

The system can also use third-party wireless networking devices that meet the following requirements:

- Devices that connect to the system using a serial link
  - support for an RS-232-standard serial communications link
  - support for the Client/Client (direct serial link) communication protocol
- Devices that connect to the system using Ethernet

*Note* – Only systems that have a CB460 control box installed can connect to a third-party radio using Ethernet. This feature is not available on the CB450 control box.

### 5.4.4 Wireless WiFi Terminology

The following sections describe the meaning of common Wi-Fi terms.

#### Wi-Fi network modes

There are two Wi-Fi network operating modes:

- Infrastructure networks
- Ad hoc networks

**Infrastructure networks** consist of two or more Wi-Fi devices, one or more of which acts as an IP data router (referred to as an *access point*) and is connected to an extended data distribution system, for example a site intranet or the Internet. Each on-machine Wi-Fi device communicates with the network via an access point. The following figure illustrates a typical infrastructure network.

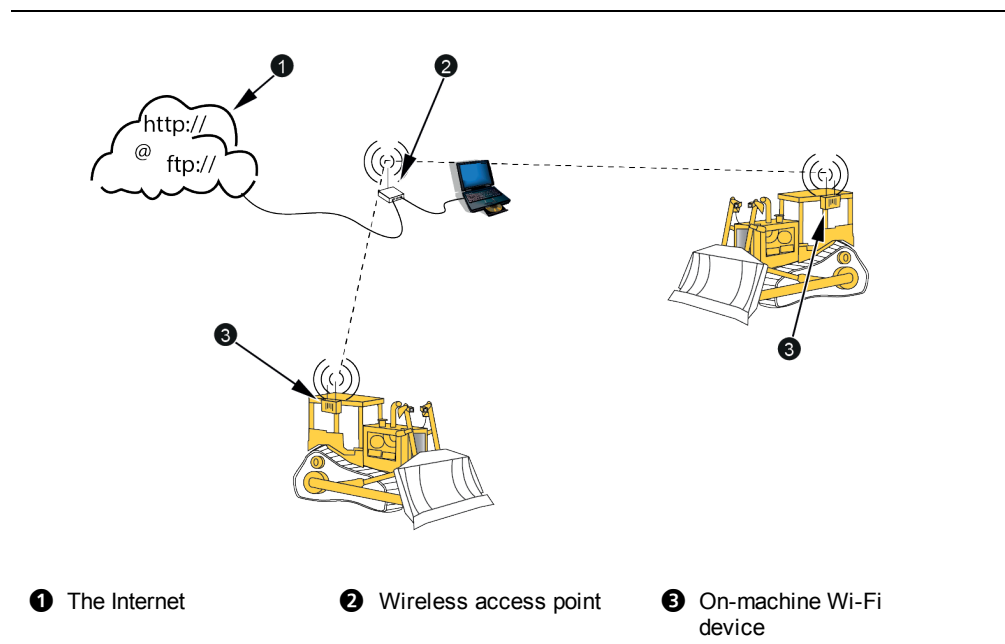

Figure 5.3 An example of an infrastructure Wi-Fi network

*Ad hoc* networks consist of two or more Wi-Fi devices communicating directly between one another, without the use of an access point. An ad hoc network does not contain an access point. If a device in an ad hoc network has an intranet or Internet connection, it may share that connection with other members of the network.

### Network name

Depending on the physical conditions on site, the range of a Wi-Fi signal is up to a few hundred meters. Since it is possible for a Wi-Fi device to be in range of more than one network, networks are identified by name. This name is technically known as the Service Set Identifier, or **SSID**.

Typically, Wi-Fi access points regularly broadcast the name of the network they are a member of, along with other information relevant to the network. This tells Wi-Fi devices not yet in a network what networks are available in their neighborhood. However, a network administrator may choose to disable this feature. Networks that do not broadcast their name and details are called **non-broadcast networks**.

### Network security

To prevent unwanted access to a Wi-Fi network, the network can be configured to require authorization before a Wi-Fi device can join the network. This process is called **authentication**. The four common types of authentication are described in the following table.

---

Authentication	Description
Open	No authentication is required.
WEP	Wired Equivalent Privacy (WEP) provides basic data confidentiality services by encrypting the data sent between Wi-Fi devices.
WPA™	Wi-Fi Protected Access (WPA) provides a method of data encryption and network authentication that is more advanced than that of WEP.
WPA2™	Wi-Fi Protected Access II (WPA2) currently provides the most secure method of encryption and network authentication for Wi-Fi networks.



## Other Devices

### In this chapter:

- Introduction
- EM400 electric mast
- PM400 power module
- LB400 external lightbars
- Valve modules
- USB keyboard

This chapter describes other devices used by the system.

## 6.1 Introduction

This chapter introduces other devices that are commonly found in the system.

## 6.2 EM400 electric mast

An EM400 electric mast controls the height above the cutting edge of the blade of a UTS target, a GNSS receiver, or LR410 laser receivers.

The following figure shows an electric mast mounted on a motor grader.



The following table lists the maximum operating heights for an electric mast when loaded with various sensor types:

Sensor	Maximum height
MS9x0 GNSS receiver	0.6 m (2 ft)
MT900 target	0.9 m (3 ft)
LR410 laser receiver	1.2 m (4 ft)

In general, electric masts should be extended the minimum amount, consistent with operating requirements.



### 6.3 PM400 power module

A power module controls and conditions the power supplied to the system components. Systems that use an SR300 survey laser receiver or an EM400 electric mast must use a power module.

The following figure shows a PM400 power module.



### 6.4 LB400 external lightbars

If your system is using a CB460 control box you can optionally connect LB400 external lightbars.

LB400 lightbars are designed for use with grade control systems. External lightbars replicate the grade and alignment information provided by the control box's integrated lightbars, however their compact size and multiple mounting options allow them to be installed in the operator's working line of sight.

The following figure shows an external lightbar mounted close to the cab floor of an excavator, to show arm extension and/or retraction.



The following table lists the physical and electrical characteristics of the LB400 lightbar.

**Table 6.1 — LB400 physical and electrical characteristics**

Item	Description
Dimensions	L: 175 mm (6.9 inch) X W: 53 mm (2.1 inch) X H: 32 mm (1.3 inch)
Weight	145 g (5 oz)
Water resistance	Waterproof to 5 psi
Communications protocol	RS-232

#### 6.4.1 Understanding lightbar information

The system uses lightbars to provide the operator with guidance information. Properly installed lightbars enable you to view guidance information, the cutting edge, and the surface you are working, simultaneously.

In each lightbar there are seven sets of LEDs, in two colors, as shown in the following figure.

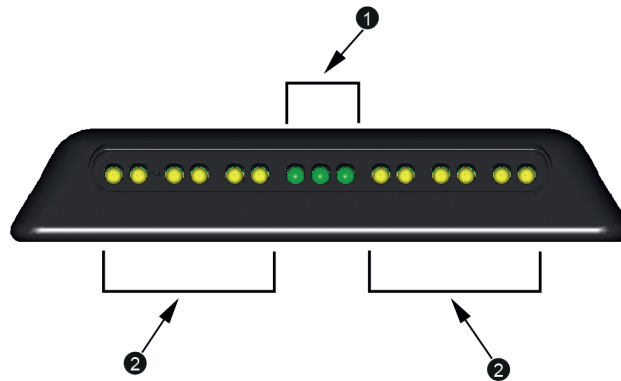

1 Green LEDs                      2 Amber LEDs

Figure 6.1 External lightbar (LB400)

The site supervisor can adjust the brightness of the LEDs.



When the cutting edge is:

- within half of the on-grade or on-line tolerance, only the central green LED is lit
- within the on-grade or on-line tolerance, the central green LED and one other green LED are lit
- off-grade or off-line, any LED, other than a green LED, is lit

The LEDs show the distance away from the design in terms of specified vertical or horizontal guidance tolerances. In the examples shown in [Table 6.2](#), the values in brackets are based on the default vertical tolerance value of 0.050 m.

A vertical tolerance value of 0.050 m means that the cutting edge is considered to be on-grade if it is within 0.050 m of the required vertical position.

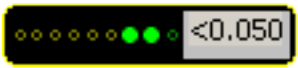
**Table 6.2 — Vertical lightbar tolerances**

This LED pattern ...	Indicates that the cutting edge is ...
	On-grade, and within half the tolerance value of the required vertical position. (Within 0.025 m.)
	On-grade, and within tolerance of the required vertical position. (Within 0.050 m.)
	Off-grade, and within 1.5 times the tolerance value of the required vertical position. (Within 0.075 m.)

This LED pattern ...	Indicates that the cutting edge is ...
	Off-grade, and within twice the tolerance value of the required vertical position. (Within 0.10 m.)
	Off-grade, and within four times the tolerance value of the required vertical position. (Within 0.20 m.)
	Off-grade, and within eight times the tolerance value of the required vertical position. (Within 0.40 m)
	Off-grade, and more than eight times the tolerance value away from the required vertical position. (Greater than 0.40 m)

Horizontal guidance information appears in the same way as the vertical position information. The default horizontal tolerance is 0.100 m.

Typical lightbar configurations are described below:

These machines ...	Have these lightbars ...
<ul style="list-style-type: none"> <li>• Bulldozers</li> <li>• Motor graders</li> <li>• Scrapers fitted with a dual-GNSS receiver system</li> </ul>	<ul style="list-style-type: none"> <li>• Two vertical</li> <li>• One horizontal</li> </ul>
Scrapers fitted with a single-GNSS receiver system	<ul style="list-style-type: none"> <li>• One vertical</li> </ul>
Excavators	<ul style="list-style-type: none"> <li>• One vertical</li> <li>• One horizontal</li> <li>• One extend/retract</li> </ul>

### Motor grader, dozer and scraper lightbar behavior

You can install up to three lightbars on motor graders, dozers and scrapers. Each lightbar shows different information for each blade position:

- One or two vertically-mounted lightbars give cut/fill guidance to the blade tip on each side.
- For 3D systems, a horizontally-mounted lightbar gives horizontal guidance.

Figure 6.2 shows how the lightbars provide guidance information and how they relate to the cross-section view of the road design, when a 3D guidance method is used. The cut/fill information is relative to the design surface. The horizontal guidance information is relative to the master alignment of the road.

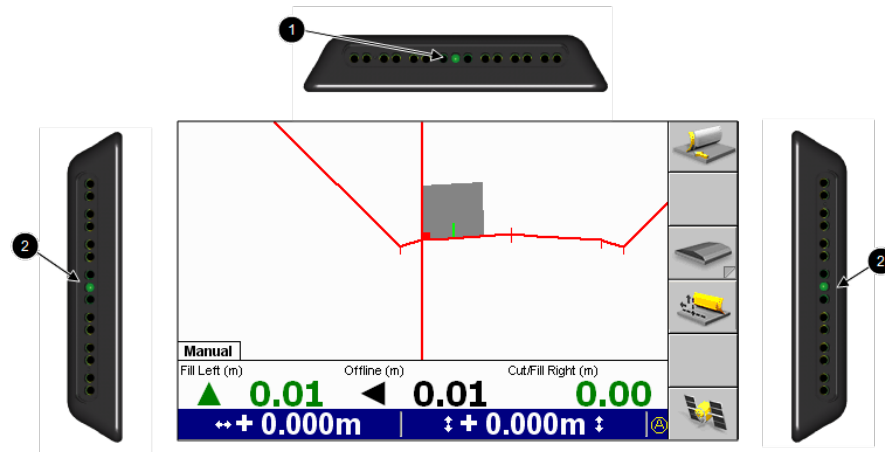

① Horizontal lightbar on line      ② Vertical lightbars on grade

Figure 6.2 3D lightbars

### Excavator lightbar behavior

You can install up to three lightbars on an excavator. Each lightbar shows different information for your blade position, as outlined in the following table:

This lightbar ...	Indicates ...	For the ...
Vertical	Corrections for cut and for fill	Lowest bucket tip relative to the design
Horizontal	Left and right corrections to the arm position relative to the horizontal alignment	Bucket tip that has focus
Extend/retract	Extension and retraction corrections to the arm position relative to the horizontal alignment	Bucket tip that has focus

The horizontal and extend/retract lightbars are not active at the same time. The system automatically selects which lightbar to activate based on the excavator’s orientation, relative to the selected horizontal alignment.

The vertical lightbar only gives guidance to one bucket tip at a time, to the following points:

- The bucket tip with the smallest *Cut* value, when both bucket tips are above the temporary working surface
- The bucket tip with the largest *Fill* value, when both bucket tips are below the temporary working surface

- The *Fill* bucket tip, when one bucket tip is below and one bucket tip is above the temporary working surface

*Note* – For machines fitted with a tilting bucket, the lightbar gives guidance to one bucket tip at a time in the same way as described above.



**Tip** – Use text items to see the cut/fill values for both bucket tips at the same time.

### Vertical lightbar guidance

The cut/fill lightbar on an excavator gives on-grade guidance to the working surface, as shown in [Figure 6.3](#).

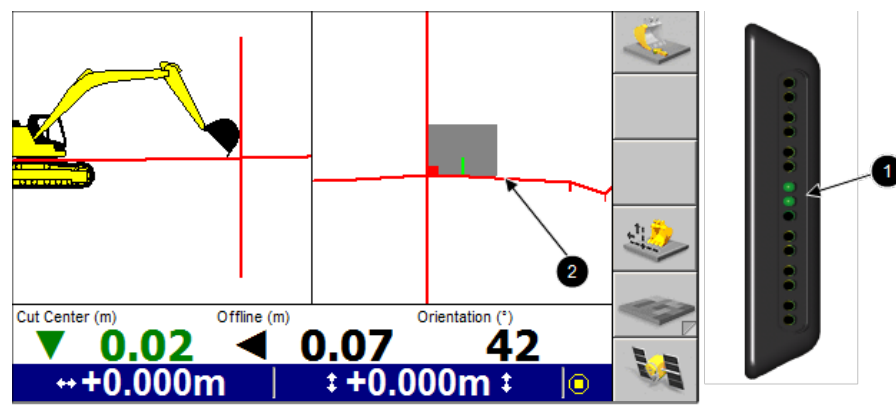

❶ Cutting edge above design – cut down

❷ Design surface

Figure 6.3 Excavator cut/fill guidance

The split screen view guidance screen and the cut/fill lightbar show the following:

- The bucket is above the working surface.
- The lightbar is providing guidance to the center of the bucket relative to the working surface.

### Left/right lightbar guidance

Excavators can operate parallel to a horizontal alignment. The left/right lightbar provides horizontal guidance once the excavator has turned, so that it is parallel to the selected alignment, as shown in [Figure 6.4](#).

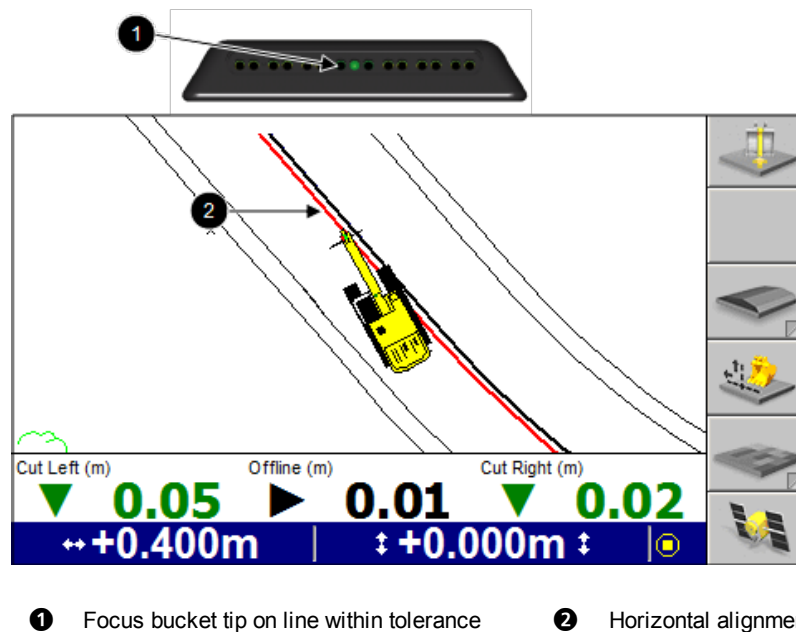



Figure 6.4 Excavator left/right guidance

Figure 6.4 also shows the following:

- The machine is parallel to the selected alignment. The lightbar gives left/right guidance to the bucket tip that has focus.
- The *Offline* text item arrow indicator gives left/right guidance.
- The bucket needs to move right 0.01 m to be on-line.
- The selected alignment (②) is shown as a thick red line.
- **Bucket Tip: Left**  and the red square on the bucket symbol shows that the left/right horizontal lightbar is providing on-line guidance to the left bucket tip.

### Extend/retract lightbar guidance

An excavator can also work square to (toward) an alignment. The extend/retract lightbar gives extension guidance to the selected alignment, as shown in Figure 6.5.

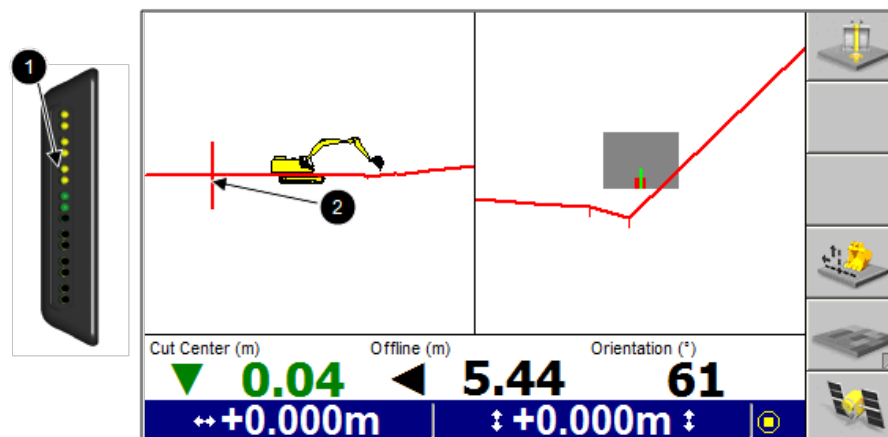

❶ Six amber LEDs flashing – retract bucket      ❷ Horizontal alignment

Figure 6.5 Excavator extend/retract guidance

Figure 6.5 also shows the following:

- The *Offline* text item arrow indicator gives extend/retract guidance.
- The bucket needs to be **retracted** 5.44 m to be on-line.
- The selected alignment is shown as a vertical red line.
- **Bucket Tip: Left**  shows that the extend/retract lightbar is providing on-line guidance to the left bucket tip.

## 6.5 Valve modules

Systems that have the automatic control option installed have a valve module that takes valve-drive messages from the control box and converts them into electrical signals used to drive the machine's electro-mechanical hydraulic valves. These valves are a part of the hydraulics system used to position the machine's cutting edge.

Valve types supported by Trimble valve modules include the following:

- Digital
- Proportional voltage
- PWM (proportional current)
- PT (proportional time)



The system supports the valve modules described in the following table.

Valve module	Type
VM410	Proportional voltage; commonly used on dozers.
VM415	Proportional voltage with a programmable voltage range.
VM420	Proportional current; commonly used on motor graders. Can be used in Proportional Time (PT) mode.
VM430	Proportional current or voltage.
Programmable valve	A CAN-enabled (programmable) valve that accepts valve drive commands directly over the CAN bus. The CAN addresses of these valve modules are programmable.
John Deere EHC	Factory fitted to John Deere dozers and motor graders.
Komatsu D155Ax-6	Factory fitted to Komatsu dozers. <b>Note</b> – Komatsu D155Ax-6 uses the bulldozer's hydraulic control unit as the valve module.

### 6.5.1 The VM410 valve module

The VM410 valve module is designed to drive Danfoss proportional voltage valves. The following figure shows a VM410 valve module.



The following table lists the physical and electrical characteristics of the VM410 valve module.

**Table 6.3 — VM410 physical and electrical characteristics**

Item	Description
Dimensions	W: 213 mm (8.4 inch) X D: 64 mm (2.5 inch) X H: 89 mm (3.5 inch)
Operating temperature	-40 °C (-40 °F) — +85 °C (+185 °F)

Item	Description
Storage temperature	-40 °C (-40 °F) — +120 °C (+248 °F)
Valve drive out	2 x Danfoss proportional voltage
Communications protocol	CAN

### 6.5.2 The VM415 valve module

The VM415 valve module is designed to drive proportional time (PT) hydraulic valves.

The following figure shows a VM415 valve module.



The following table lists the physical and electrical characteristics of the VM415 valve module.

**Table 6.4 — VM415 physical and electrical characteristics**

Item	Description
Dimensions	W: 213 mm (8.4 inch) X D: 64 mm (2.5 inch) X H: 89 mm (3.5 inch)
Operating temperature	-40 °C (-40 °F) — +85 °C (+185 °F)
Storage temperature	-50 °C (-58 °F) — +120 °C (+248 °F)
Valve drive out	2x PT
Communications protocol	CAN

### 6.5.3 The VM420 valve module

The VM420 valve module is designed to drive PWM (proportional current), and PT (proportional time) valves.

The following figure shows a VM420 valve module.



The following table lists the physical and electrical characteristics of the VM420 valve module.

**Table 6.5 — VM420 physical and electrical characteristics**

Item	Description
Dimensions	W: 213 mm (8.4 inch) X D: 64 mm (2.5 inch) X H: 89 mm (3.5 inch)
Operating temperature	-40 °C (-40 °F) — +85 °C (+185 °F)
Storage temperature	-40 °C (-40 °F) — +120 °C (+248 °F)
Valve drive out	2 x PWM/PT
Communications protocol	CAN

#### 6.5.4 The VM430 valve module

The VM430 valve module is designed to drive proportional voltage, PWM (proportional current), and PT (proportional time) valves.

The following figure shows a VM430 valve module.



The following table lists the physical and electrical characteristics of the VM430 valve module.

**Table 6.6 — VM430 physical and electrical characteristics**

Item	Description
Dimensions	W: 158 mm (6.23 inch) X D: 142 mm (5.59 inch) X H: 52 mm (2.03 inch)
Operating temperature	-40 °C (-40 °F) — +70 °C (+158 °F)
Storage temperature	-40 °C (-40 °F) — +85 °C (+185 °F)
Protection rating	IEC 60068-2-xx
Power consumption	Peak: 24.0 A (at 12 V DC)
Valve drive out	8 x Digital/PV/PWM/PT
Communications protocol	CAN

## 6.6 USB keyboard

A USB Keyboard can be used to enter alphanumeric values for dimensions and text. This capability is particularly useful during the installation process.

Any QWERTY keyboard compatible with the standard USB HID device driver can be used, for example a Microsoft® Comfort Curve Keyboard.

The keyboard can be plugged into the USB port on the front of any CB450/CB460 control box.

***Note** – Keys outside the standard layout will not work (such as media keys, internet and volume).*

## Design Surfaces, Vertical Guidance, and Offsets

### In this chapter:

- Introduction
- Specifying a design surface
- Vertical offset

Every site has a defined construction surface, based on the engineering design for the project. This is called the *design surface*.

This chapter describes how the design surface is defined, and how guidance information is calculated, for conventional and 3D systems.

## 7.1 Introduction

The GCS900 Grade Control System generates vertical guidance information by comparing the elevation of one or two points on the cutting edge of the blade, called vertical guidance points, with the elevation of the design surface above or below the vertical guidance point(s).

The system reports the corrections that the cutting edge must make in terms of cut or fill values. If the cutting edge must move:

- **down** to achieve the design elevation then the correction is a **cut** value
- **up** to achieve the design elevation then the correction is a **fill** value

## 7.2 Specifying a design surface

You can specify a design surface in the following ways:

- For a conventional design surface, create a physical reference surface, and then specify the elevation difference between the physical reference surface and the design.
- For a 3D design surface, load or create a 3D design file.

### 7.2.1 Conventional design surfaces and benching

To define a conventional design surface:

- Establish a reference surface. This is typically done in one of the following two ways:
  - For systems that use a laser receiver as a lift sensor, create a laser plane with a laser transmitter. The system generates cut/fill values that position the laser receiver so that the laser beam strikes the receiver's detectors at their vertical mid-point.
  - For systems that use a sonic tracer as a lift sensor, build a string line or curb or grade a reference plane. The system generates cut/fill values that position the sonic tracer so that the distance between the tracer and the reference surface remains constant.
- Fix the height of the reference surface, as determined by the lift sensor, relative to a known position of the cutting edge. This process is known as benching. The position of the cutting edge can be measured against a benchmark with a known elevation, or relative to the reference surface itself.

- Determine the difference in elevation between the design surface and the benchmark. This difference is known as the **reference elevation**. As you work, the offset represented by the reference elevation will reduce to zero.

Figure 7.1 shows the relationship between: the reference surface, in this case a laser plane, the elevation of the design surface, and the benchmark elevation. Because the design surface and the benchmark are not at the same elevation, the reference elevation is non-zero. In operation, the system will generate cut/fill values that will move the blade up and down to maintain the laser strike on the mid-line of the laser receivers. As the surface being worked is cut down to the design surface, the reference elevation will reduce to zero.

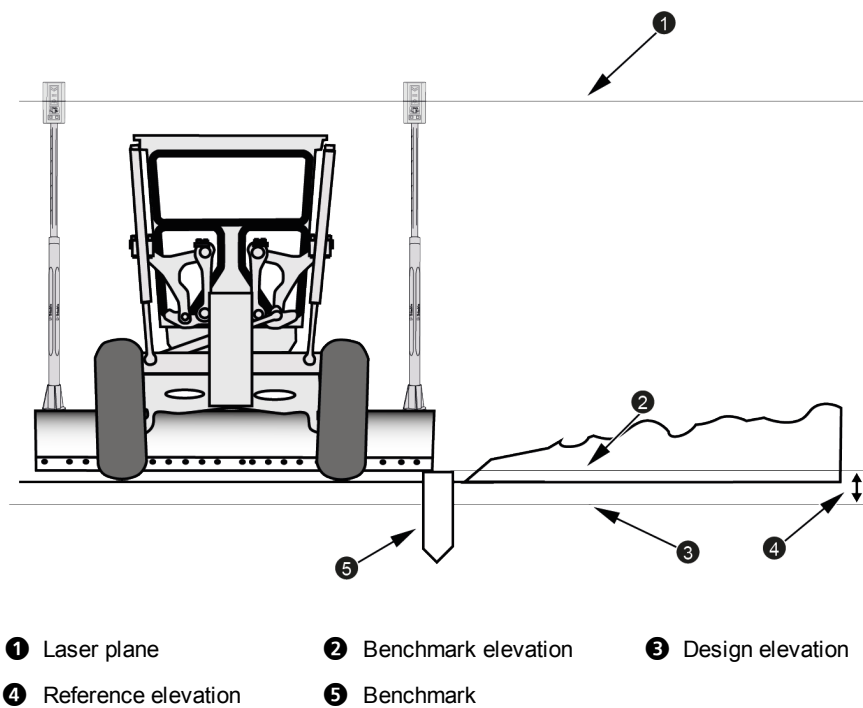
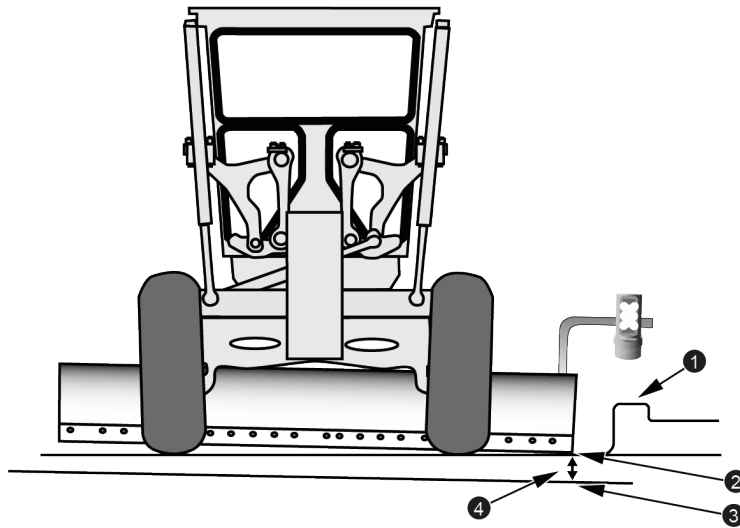

Figure 7.1 Benching a dual laser system

Figure 7.2 shows the relationship between the reference surface, in this case an existing curb line, and the benchmark elevation. In operation, the system will generate cut/fill values that will move the blade up and down to maintain a constant distance between the sonic tracer and the reference surface. As the surface being worked is cut down to the design surface, the reference elevation will reduce to zero.



- ① Reference surface      ② Benchmark elevation      ③ Design elevation and slope  
④ Reference elevation

Figure 7.2 Benching a sonic tracer system

### 7.2.2 3D design surfaces and design files

A 3D design surface is defined by a digital design surface file, or design. A design must contain a 3D design surface and can also contain background linework.

The design surface contains vertical guidance information for a specific area. The design surface can be an irregular surface or a plane.

Typically, design files are created in the office and saved onto a USB flash drive. You can load the design file directly onto the control box from the USB flash drive.

A USB flash drive can contain more than one design file. However, the system will only load one design at a time.

The system supports the following design file types:

- SV Design (.svd)
- Road (.dc)
- Triangular Irregular Network (TIN) (.ttm)
- Grid (.dtx)
- Sloping Surface (.tsd)



- Level Surface (.tsd)
- 3D Lines Design (.svl)

These file types are described in the following sections.

### SVD files

An SVD file is a fast loading design surface. An SVD file enables a machine to operate across very large design surfaces.

You can only use Trimble SiteVision Office or Business Center – HCE software to generate an SVD file.

### Road files

A road file uses horizontal and vertical alignments to describe a road surface. A series of templates or standard cross-sections are then applied to these alignments to define the road design surface.

### TIN files

A TIN file describes a design surface formed by a mesh of triangles.

A TIN is a better way of modeling the design surface than a grid. A TIN more accurately represents sharp edges, and usually models the same design with fewer points.

### Grid files

A grid file is a regular rectangular grid of points. A height is assigned to each point in the grid.

### Level and sloping surface files

The system enables you to create the following 3D design surfaces in the field:

- Level surfaces
- Sloping surfaces

Creating a level or sloping surface generates a design file, which you must load into the system for machine guidance.

When an engineer creates a level or sloping surface design in the office they will typically define the extents of the design with a design boundary. When you create a simple surface design in the field, the design is effectively unbounded.

A level surface is a simple, flat, horizontal surface defined by elevation. A level pad can be constructed using a level surface design.

Sloping surfaces are defined by a master alignment and a cross slope on either side, as shown in the following figure.

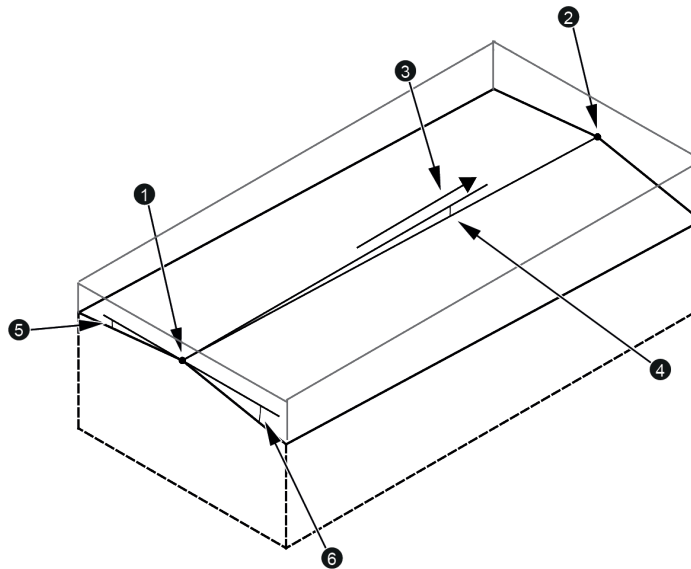

- |           |                    |                      |
|-----------|--------------------|----------------------|
| ① Point 1 | ② Point 2          | ③ Direction of grade |
| ④ Grade   | ⑤ Left cross slope | ⑥ Right cross slope  |

Figure 7.3 Sloping surface design elements

There are two methods for defining a sloping surface:

- Two-Points:
  - Both Point 1 and Point 2 consist of Northing and Easting positions, and an elevation.
  - Both points must be on the surface you want to work to.
  - The system connects the first point to the second point. The connecting line is called the *master alignment*.
- Point-and-Direction:
  - Defines the master alignment with a starting point, direction, and grade.
  - The direction specifies the bearing of the master alignment.
  - The grade is the grade at which the master alignment rises or falls along the specified bearing, and can be entered as a ratio or percentage. A grade of 1:1000 (or 0.1%) is nearly level and a grade of 1:8 (or 12.5%) is very steep for a road.
  - As you travel in the specified direction, a positive (+) grade rises and a negative (–) grade falls.

- The specified values are used to create the master alignment of the sloping surface.

Both methods require you to specify a cross slope. Cross slope is the slope at right angles to the direction of the master alignment. A typical cross slope for a road is 3%.

You must define the cross slope to the left and to the right of the master alignment. The cross slopes to the left and right of the master alignment can be set independently.

### 3D Lines design files

3D Lines designs (.svl files) specify one or more 3D lines, along with optional background linework.

3D Lines designs are useful for representing features such as paths, drains and pipelines. Working to a 3D line is like working to a virtual string line.

A 3D Lines design has the following features:

- One or more 3D lines are available for selection.
  - The width of the design surface defined by a selected 3D line can be varied.
  - The length of a selected 3D line, and hence the design surface defined by it, can be extended.
- The cross slope of the design surface defined by a 3D line is always level.
- The direction and grade of the design surface defined by a 3D line can change between segments.
- A 3D line has named start and end points. The start point is named A and the end point is named B.

The following figure shows a 3D line in plan view.

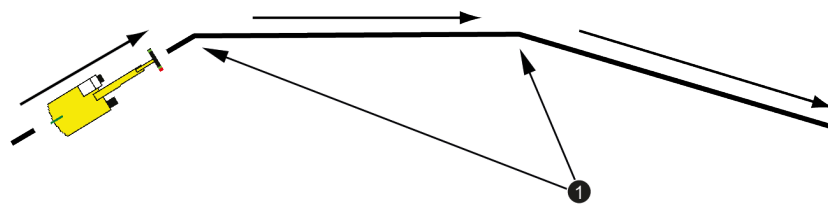

① Change in direction at segment boundary

Figure 7.4 A 3D line design in plan view

The following figure shows a 3D line in profile view.

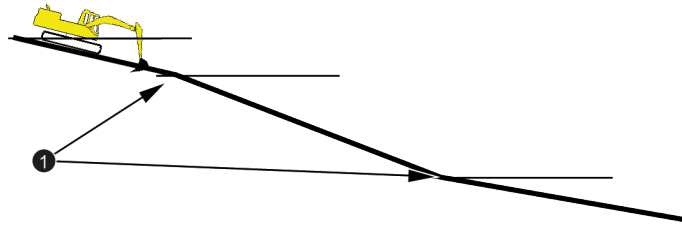

- ① Change in grade at segment boundary

---

Figure 7.5 A 3D line design in profile view

You can only use Trimble SiteVision Office or Business Center – HCE software to generate a 3D Lines design file.

### 7.3 Vertical offset

In general, it is not possible for an operator to reach the design surface in a single pass, because the original surface is too far away from the design surface in elevation and/or slope.

The system enables you to add a positive or negative offset to the design elevation to create a surface that is achievable in a single pass. This vertical offset is reduced to zero over a number of passes, as the target surface for each pass approaches the design surface.

Vertical offset is applied to a sensor's vertical guidance point.

The following figure shows a motor grader using a single-GNSS plus the cross slope sensor group to work to a design surface. The system uses the GNSS receiver to monitor the position of the left blade tip. To monitor the right blade tip, the system uses the information supplied by the cross slope sensor group to project the position of the left blade tip out to the right blade tip.

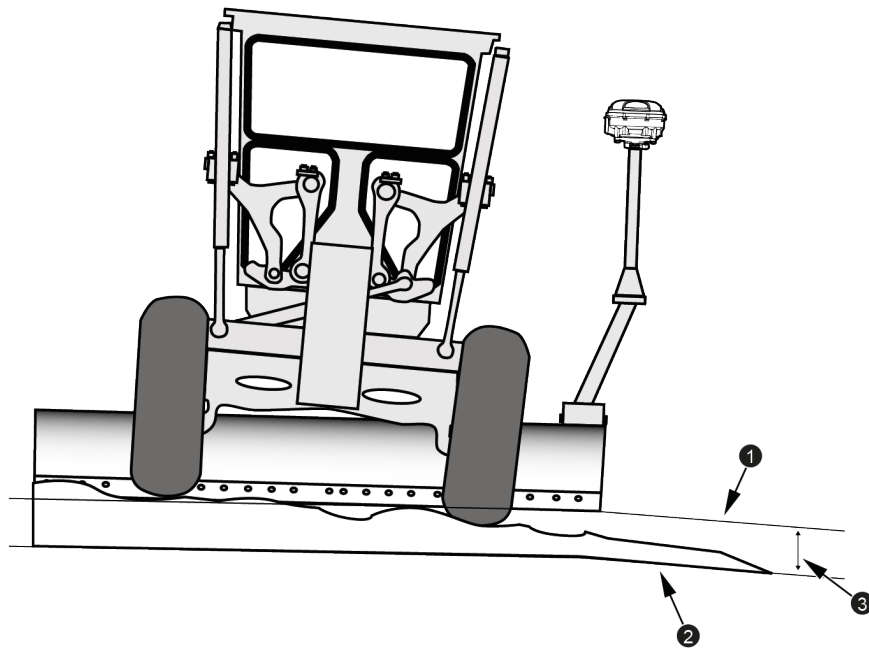

- ❶ Working surface
- ❷ Design surface
- ❸ Vertical offset

Figure 7.6 Vertical offset from a 3D design surface

The operator has set a vertical offset to create a working surface that is above the design surface. The following figure shows how this might look in the cross-section view guidance screen.

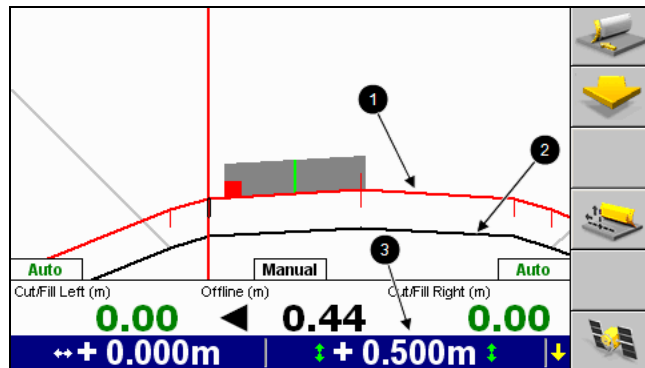

- ❶ Working surface
- ❷ Design surface
- ❸ Vertical offset value

Figure 7.7 3D guidance with vertical offset

The following figure shows a motor grader using lift plus cross slope conventional guidance to work to a design surface. The height of the left blade tip is monitored by a sonic tracer measuring its distance from an existing curb line. The height of the right blade tip is monitored by cross slope sensors.

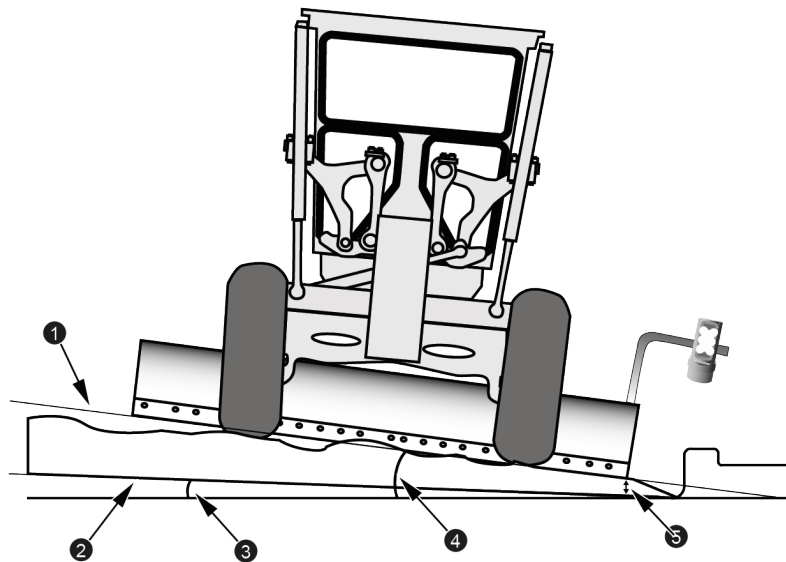

- |                       |                   |                      |
|-----------------------|-------------------|----------------------|
| ❶ Working surface     | ❷ Design surface  | ❸ Design cross slope |
| ❹ Working cross slope | ❺ Vertical offset |                      |

Figure 7.8 Vertical and slope offset from a conventional design surface

The operator has set a vertical offset to lift the left blade tip to a workable height above the design surface, and increased the slope to an achievable value. The following figure shows how this might look in the cross-section view guidance screen.

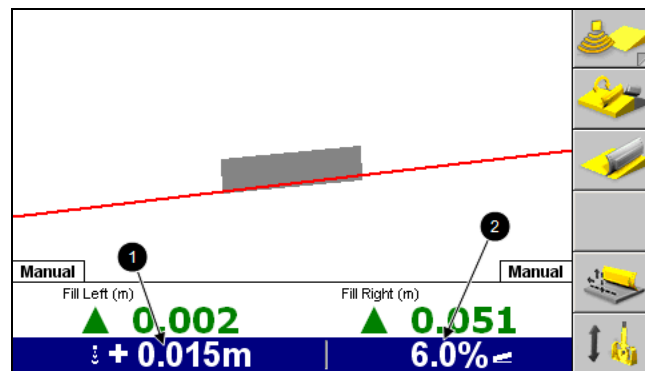

❶ Vertical offset

❷ Working cross slope

Figure 7.9 Example of vertical offset in a conventional guidance system

For 3D systems, vertical offset can only be used when the center of the blade, or one or both ends of the blade, are receiving guidance.

For conventional systems, vertical offset can only be used when one end of the blade is receiving lift guidance.





## Conventional Guidance Systems

### In this chapter:

- Introduction
- Conventional guidance methods
- Sensor swap
- Automatic slope swap
- Dip reduction (blade rotation compensation)

This chapter describes the conventional guidance methods the GCS900 Grade Control System supports.

## 8.1 Introduction

Conventional guidance provides cutting edge guidance relative to an external reference such as a laser plane, string line or gravity, and is independent of the location of the machine. It is useful for constructing flat and sloping pads, and grade matching.

In addition to conventional systems, single-3D sensor systems also offer conventional guidance.

## 8.2 Conventional guidance methods

Depending on the sensors installed, the system supports the following conventional guidance methods:

- Blade slope
- Lift
- Lift plus blade slope
- Cross slope
- Lift plus cross slope
- Independent lift
- Linked lift

For more information, refer to the *GCS900 Grade Control System Operator's Manual* for your machine type.

### 8.2.1 Blade slope guidance

Blade slope guidance enables you to set and maintain a constant cutting edge slope, and is only available on motor graders and non-A4:M1 dozers with an AS400 blade slope sensor installed.

Blade slope guidance is useful for constructing and trimming basic roads and flat and sloping pads.

If you use automatic controls, blade slope guidance enables you to maintain the correct blade slope. For motor graders, you can control the height of the cutting edge by manually adjusting the height of one blade tip, while the automatic controls adjust the height of the other blade tip.

### Blade slope sensors

The following table lists the minimum sensor combination required for blade slope guidance:

Sensors	Comments
Blade slope	Blade must be square to the machine, or rotation accounted for. Requires manual control of blade height.

The following figure shows a motor grader with blade slope sensor installed.

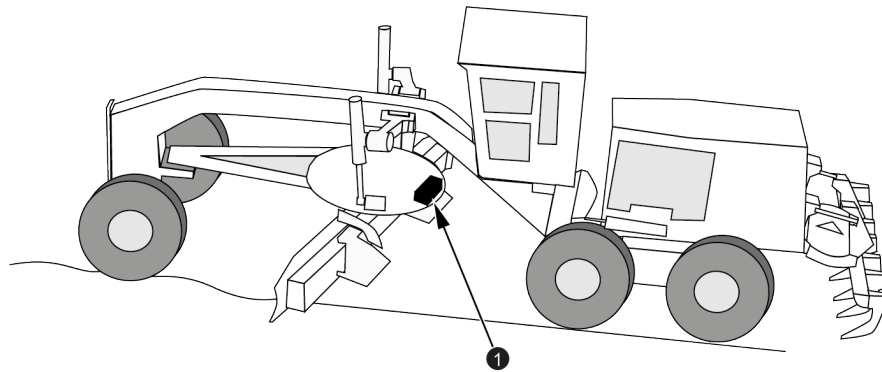

❶ Blade slope sensor

Figure 8.1 A typical blade slope guidance system

### Blade slope guidance views

The following figure shows the cross-section view guidance screen when the system is gathering blade slope data.

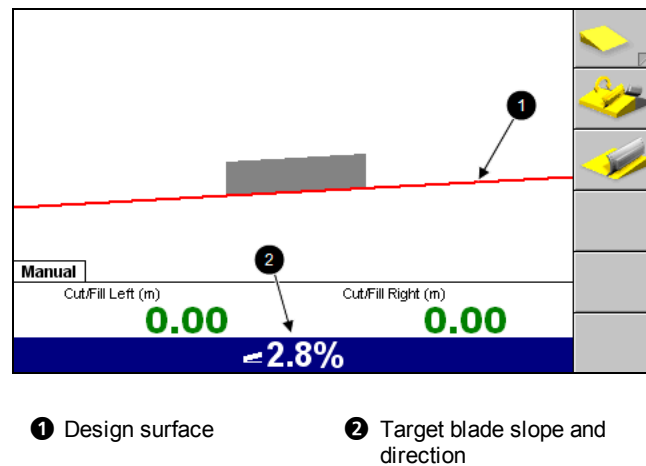

Figure 8.2 A blade slope only cross-section guidance screen

Points to note in [Figure 8.2](#):

- The blade slope icon appears to the *left* of the target blade slope value, indicating that the system is generating guidance for the *left* blade tip.
- If automatic controls were engaged, the *left* ram would be driven to correct any errors in blade slope. This is indicated by the single automatic controls status indicator, which appears in the bottom *left* of the guidance area.
- The target blade slope of 2.8% appears in the guidance settings area. The direction of the target blade slope is down to the left. This is indicated by the direction of the blade slope icon's slope.
- Because a blade slope system does not generate absolute elevation data, guidance information is not generated for the *right* tip. Even if automatic controls were enabled, it would still be up to the operator to manually adjust the *right* blade tip to the correct elevation.

When you use blade slope guidance, two optional text guidance screens are available in addition to the cross-section view guidance screen.

### Blade slope lightbar information

When you use blade slope guidance, the lightbars only give guidance to one blade tip, and only the lightbar corresponding to that tip is active. Both the horizontal lightbar and the lightbar corresponding to the unguided blade tip are off.

## 8.2.2 Lift guidance

Lift guidance enables the operator to set and maintain a constant cutting edge height relative to a reference elevation. There is a single vertical guidance point which is located on or beyond the cutting edge of the blade.

Lift guidance is useful for constructing batters and flat and sloping pads. For machines with automatic controls, one-point lift guidance enables the operator to adjust the height of one blade tip manually, while the automatic controls adjust the height of the other blade tip.

### Lift sensors

The following table lists the minimum sensor combinations required for lift guidance:

Sensors	Comments
Single laser receiver	The vertical guidance point is on the cutting edge, at the point directly underneath the laser receiver when the blade is level. If the laser plane is tilted, you must work parallel to the mainfall of the design.
Sonic tracer	The vertical guidance point is beyond the end of the cutting edge, at the point directly underneath the sonic tracer when the blade is level.

The following figure shows a motor grader with a single laser receiver providing lift guidance to the left blade tip.

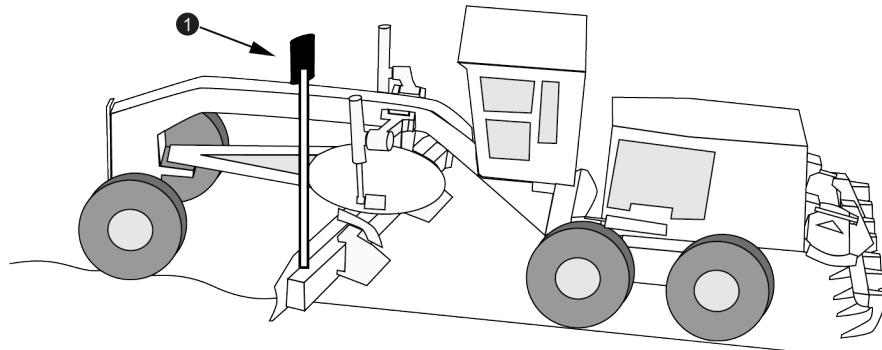

① Laser receiver

Figure 8.3 A typical lift guidance system

### Lift guidance views

The following figure shows the cross-section view guidance screen when the system is gathering lift guidance data.

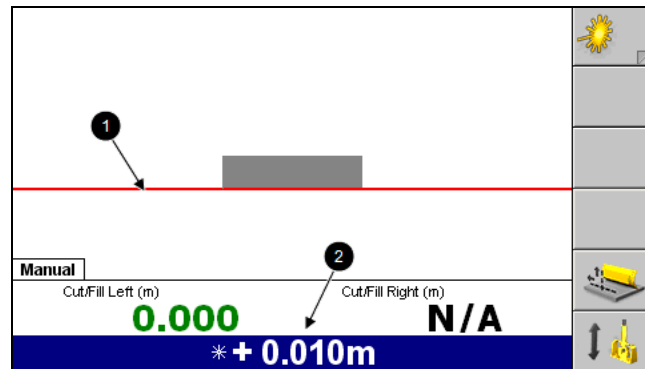

❶ Design surface

❷ Vertical offset value

Figure 8.4 A lift cross-section view guidance screen

Points to note in [Figure 8.4](#):

- The position of the laser icon, which appears to the *left* of the desired elevation value, indicates that the system is generating guidance for the *left* blade tip. If the system were fitted with automatic controls, and these were engaged, it would be the *left* ram that would be driven to correct any errors in the height off the left tip.
- The desired elevation of +0.010 m appears in the guidance settings area. The desired elevation is based on the reference value chosen when the lift sensor was benched. In this example, the laser was given a reference elevation of 0 m when it was benched, and an offset of 1 cm added. This causes the system to give guidance to a plane 1 cm above the benchmark. For more information, refer to the *GCS900 Grade Control System Operator's Manual* for your machine type.
- Because a one-point lift system does not generate absolute elevation or mainfall data, the system assumes that the non-guided blade tip, in this case the *right* tip, is always at the correct elevation on a level plane. Even if the system had automatic controls fitted, it would still be up to the operator to manually adjust the *right* blade tip to the correct elevation.

When you use lift guidance, there are two optional text guidance screens available in addition to the cross-section view guidance screen.

### Lift lightbar information

When you use lift guidance, the lightbars only give guidance to one blade tip, and only the lightbar corresponding to that tip is active. Both the horizontal lightbar and the lightbar corresponding to the unguided blade tip are off.

### 8.2.3 Lift plus blade slope guidance

Lift plus blade slope guidance is a combination of blade slope guidance and one-point lift guidance. There is a single vertical guidance point located on or beyond the cutting edge of the blade.

Lift plus blade slope guidance enables you to complete the following tasks simultaneously:

- Set and maintain the height of one tip of the cutting edge relative to a reference surface
- Control the height of the other tip of the cutting edge, to maintain the blade slope at a constant value

For machines with automatic controls, the height of both blade tips are controlled in the following way:

- The height of one blade tip is adjusted by the automatic controls to maintain a preset value relative to a reference surface
- The height of the other blade tip is adjusted by the automatic controls to maintain a preset blade slope

Lift plus blade slope guidance is useful for constructing basic roads, batters and flat and sloping pads.

### Lift plus blade slope sensors

The following table lists the minimum sensor combinations required for lift plus blade slope guidance:

Sensors	Comments
Blade slope sensor and laser receiver	The vertical guidance point is on the cutting edge, at the point directly underneath the laser receiver when the blade is level.
Blade slope sensor and sonic tracer	The vertical guidance point is beyond the end of the cutting edge, at the point directly underneath the sonic tracer when the blade is level.

The following figure shows a motor grader with blade slope sensor and sonic tracer, providing lift control of the left blade tip and blade slope control of the right blade tip.

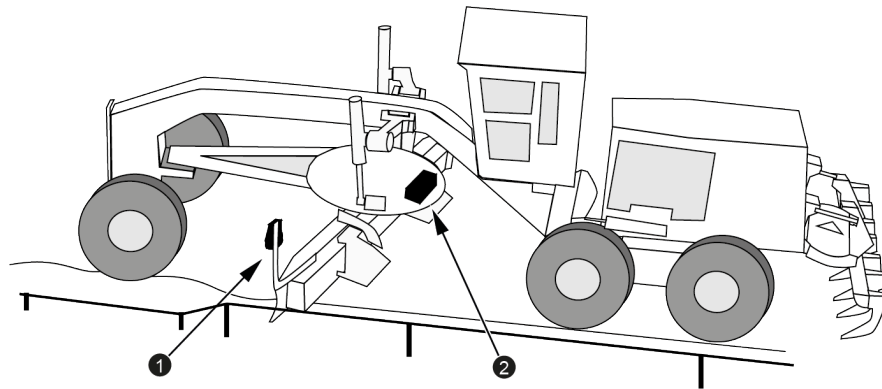

- ❶ Sonic tracer
- ❷ Blade slope sensor

Figure 8.5 A typical lift plus blade slope system

### Lift plus blade slope guidance views

The following figure shows the cross-section view guidance screen when the system is gathering lift plus blade slope data.

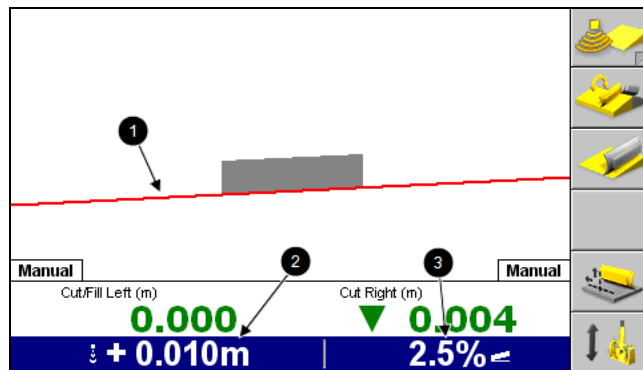

- ❶ Design surface
- ❷ Vertical offset
- ❸ Target slope

Figure 8.6 Lift plus blade slope cross-section view guidance screen



Points to note in [Figure 8.6](#):

- The system is generating guidance for both blade tips.
- The position of the sonic tracer icon, which appears on the *left* of the guidance setting area, and to the *left* of the reference elevation value, indicates that a sonic tracer is providing lift guidance for the left blade tip. If the system were fitted with automatic controls, and these were engaged, it would be the *left* ram that would be driven to correct any errors in blade height.
- The elevation offset of +0.010 m appears in the guidance settings area next to the sonic tracer icon.
- The position of the blade slope icon, which appears on the *right* of the guidance setting area, and to the *right* of the target blade slope value, indicates that the blade slope sensor is providing blade slope guidance for the right blade tip. If the system were fitted with automatic controls, and these were engaged, it would be the *right* ram that would be driven to correct any errors in blade slope.

When you use lift plus blade slope guidance, in addition to the cross-section view guidance screen, there are also two optional text guidance screens available.

#### Lift plus blade slope lightbar information

When you use lift guidance, the left and right vertical lightbars will give guidance to both blade tips. The horizontal lightbar will be off.

### 8.2.4 Cross slope guidance

Cross slope guidance enables you to set and maintain a constant cutting edge slope, as viewed in the direction of travel of the machine, independent of the mainfall (pitch) and cross slope (roll) of the machine and the rotation of the blade.

Cross slope guidance is useful for constructing roads, batters, and flat and sloping pads.

If you use automatic controls, cross slope guidance enables you to control the height of the cutting edge by manually adjusting the height of one blade tip. The automatic controls adjust the height of the other blade tip to maintain the correct cross slope.

#### Cross slope sensors

The following table lists the minimum sensor combinations required for cross slope guidance:

Sensors	Comments
Cross slope sensor group	Requires manual control of blade height.

The following figure shows a motor grader with the cross slope sensor group installed.

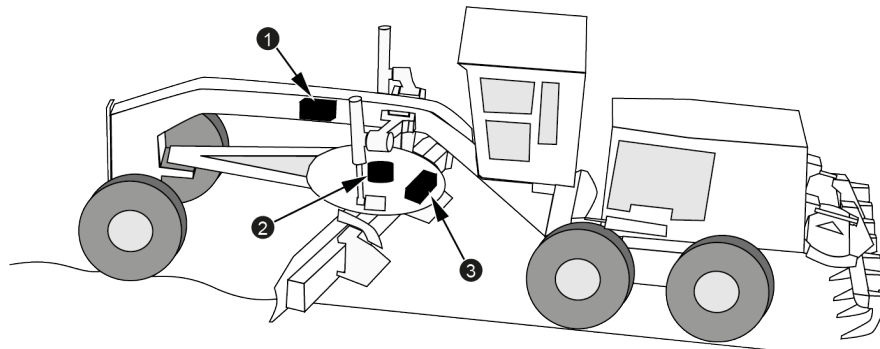

❶ Mainfall sensor

❷ Blade rotation sensor

❸ Blade slope sensor

Figure 8.7 A typical cross slope guidance system

### Cross slope guidance views

The following figure shows the cross-section view guidance screen when the system is gathering blade cross slope data.

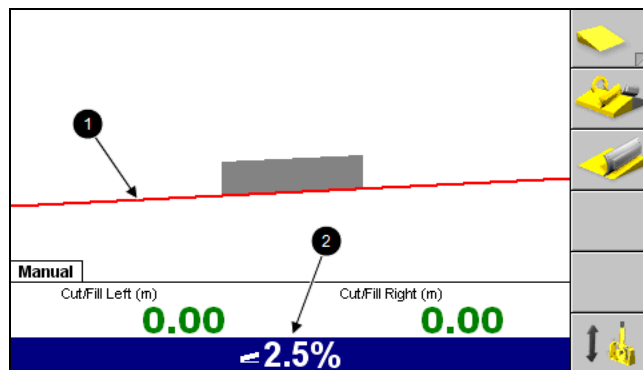

❶ Design surface

❷ Target cross slope

Figure 8.8 A cross slope cross-section view guidance screen

Points to note in [Figure 8.8](#):

- The cross slope icon, which appears to the *left* of the target cross slope value, indicates that the system is generating guidance for the *left* blade tip.

- If automatic controls were engaged, it would be the *left* ram that would be driven to correct any errors in cross slope. This is indicated by the single automatic controls status indicator, which appears in the bottom *left* of the guidance area.
- The target cross slope of 2.5% appears in the guidance settings area. The direction of the target cross slope is down to the left. This is indicated by the direction of the cross slope icon's slope.
- Because there is no absolute elevation data generated by a blade slope system, no guidance information is generated for the *right* tip. Even if automatic controls were enabled, it would still be up to the operator to manually adjust the *right* blade tip to the correct elevation.

In addition to the cross-section screen, there are also two optional text guidance screens available when you are using cross slope guidance.

#### Cross slope lightbar information

When you use blade cross slope guidance, the lightbars only give guidance to one blade tip, and only the lightbar corresponding to that tip is active. Both the horizontal lightbar and the lightbar corresponding to the unguided blade tip are off.

### 8.2.5 Lift plus cross slope guidance

Lift plus cross slope guidance is a combination of cross slope guidance and one-point lift guidance. There is a single vertical guidance point located on or beyond the cutting edge of the blade.

Lift plus cross slope guidance enables you to simultaneously:

- Set and maintain the height of one tip of the cutting edge constant relative to a reference elevation.
- Control the height of the other tip of the cutting edge, to maintain the cross slope of the cutting edge at a constant value, independent of the mainfall and cross slope of the machine and the rotation of the blade.

Lift plus cross slope guidance is useful for constructing basic roads, batters, and flat and sloping pads. For machines with automatic controls, you can control the height of both blade tips in the following way:

- The automatic controls adjust the height of one blade tip to maintain a preset value
- The automatic controls adjust the height of the other blade tip to maintain a preset cross slope

### Lift plus cross slope sensors

The following table lists the minimum sensor combinations required for lift plus cross slope guidance:

Sensors	Comments
Cross slope sensor group and laser receiver	The vertical guidance point is on the cutting edge, at the point directly underneath the laser receiver when the blade is level.
Cross slope sensor group and sonic tracer	The vertical guidance point is beyond the end of the cutting edge, at the point directly underneath the sonic tracer when the blade is level.

The following figure shows a motor grader with mainfall, blade slope and blade rotation sensors and a sonic tracer providing lift control of the left blade tip and cross slope control of the right blade tip.

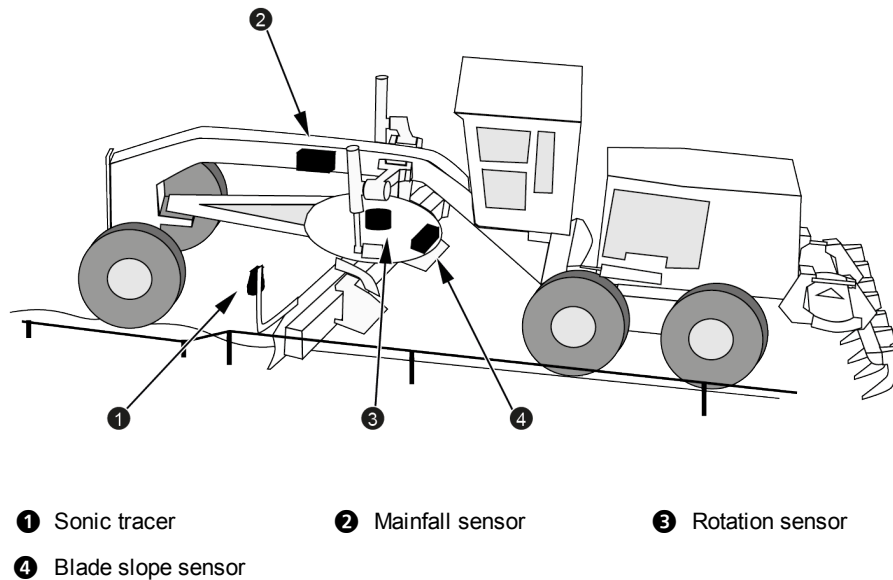
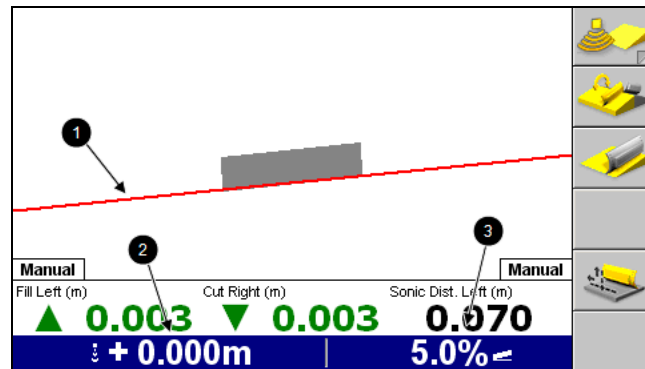

Figure 8.9 A typical lift plus cross slope system

### Lift plus cross slope guidance views

The following figure shows the cross-section view guidance screen when the system is gathering lift plus cross slope data.



- ❶ Target surface
- ❷ Vertical offset
- ❸ Target cross-slope

Figure 8.10 Lift plus cross slope cross-section view

Points to note in [Figure 8.10](#):

- The system is generating guidance for both blade tips.
- The position of the sonic tracer icon, which appears on the *left* of the guidance setting area, and to the *left* of the desired elevation value, indicates that a sonic tracer is providing lift guidance for the *left* blade tip. If the system were fitted with automatic controls, and these were engaged, it would be the *left* ram that would be driven to correct any errors in blade height.
- The current elevation offset of +0.000 m appears in the guidance settings area, next to the sonic tracer icon.
- The position of the cross slope icon (on the *right* of the guidance setting area, and to the *right* of the target cross slope value) indicates that the cross slope sensor group is providing cross slope guidance for the *right* blade tip. If the system were fitted with automatic controls, and these were engaged, it would be the *right* ram that would be driven to correct any errors in blade cross slope.

When you use lift plus cross slope guidance, in addition to the cross-section view guidance screen, there are also two optional text guidance screens available.

### Lift plus cross slope lightbar information

When you use lift plus cross slope guidance, the lightbars will give guidance to both blade tips, and only the lightbar corresponding to the tips will be active.

## 8.2.6 Independent lift-lift guidance

Independent lift guidance combines two independent instances of single lift guidance. Each end of the cutting edge is guided by a lift sensor, and each lift sensor can use a different elevation reference.

There are two vertical guidance points located on or beyond the cutting edge of the blade.

Independent lift guidance enables you to simultaneously set and maintain the height of:

- one tip of the cutting edge, relative to one reference elevation
- the other tip of the cutting edge, relative to another reference elevation

### Independent lift sensors

The following table lists the minimum sensor combinations required for independent lift-lift guidance:

Sensors	Comments
Dual laser receivers	The vertical guidance points are on the cutting edge, at the points directly underneath the laser receivers when the blade is level.
Dual sonic tracers	The vertical guidance points are beyond the end of the cutting edge, at the point directly underneath the sonic tracer when the blade is level.

The following figure shows a motor grader with dual laser receivers providing independent lift-lift guidance.

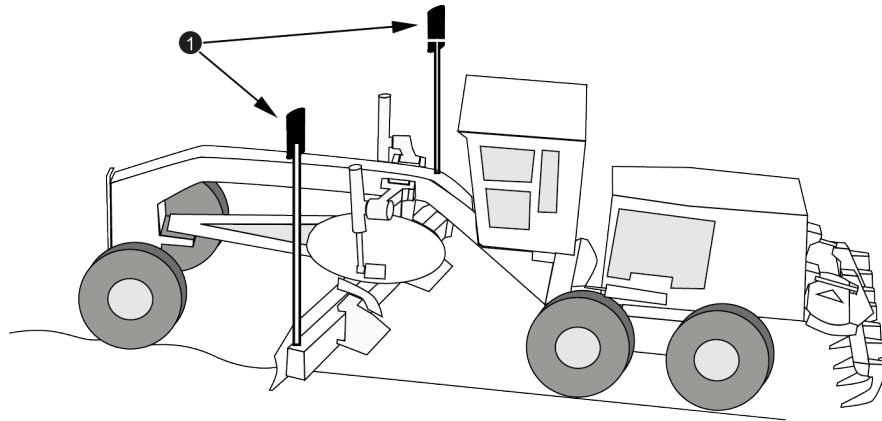

❶ Laser receivers

Figure 8.11 A typical independent lift-lift system

For information about independent lift-lift guidance techniques, refer to the Operator’s Manual for your machine.

**Independent lift-lift guidance views**

The following figure shows the cross-section view guidance screen when the system is gathering independent lift data.

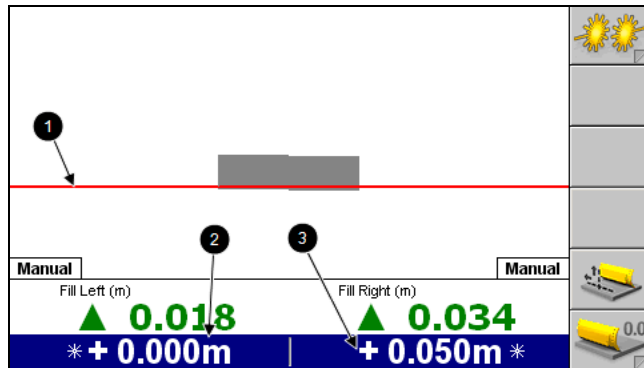

❶ Design surface                      ❷ Left vertical offset  
 ❸ Right vertical offset

Figure 8.12 Independent lift-lift cross section view

Points to note in [Figure 8.12](#):

- The system is generating guidance information for both blade tips.
- The position of the laser icon (on the *left* of the guidance setting area, and to the *left* of the desired elevation value) indicates that a laser receiver is providing lift guidance for the left blade tip. If the system were fitted with automatic controls, and these were engaged, it would be the *left* ram that would be driven to correct any errors in the left tip height.
- Lift guidance is being provided for the right blade tip by a laser receiver. This is indicated by the position of the laser icon, which appears on the *right* of the guidance setting area, and to the *right* of the desired elevation value. If the system were fitted with automatic controls, and these were engaged, it would be the *right* ram that would be driven to correct any errors in the right tip height.
- The cross slope and elevation of the working surface is calculated using the left and right reference heights entered when the laser receivers were benched, and the left and right mast extensions after benching.

When you use independent two-point lift guidance, in addition to the cross-section view guidance screen, there are also two optional text guidance screens available.

#### Independent lift lightbar information

When you use blade cross slope guidance, the light bars will give guidance to both blade tips, and only the light bars corresponding to the tips will be active. The horizontal light bar is off.

### 8.2.7 Linked lift-lift guidance

Linked lift-lift guidance combines two dependent instances of lift guidance. The two blade tips will be at the same distance from the working surface and will move up and down together.

Linked lift-lift guidance is useful for constructing batters and flat and sloping pads. For machines with automatic controls, linked lift-lift guidance enables the operator to steer the machine while the controls adjust the height and slope of the cutting edge so that it remains parallel to the reference surface.



**Linked lift-lift sensors**

The following table lists the minimum sensor combination required for linked lift-lift guidance.

Sensors	Comments
Dual laser receivers	The vertical guidance points are on the cutting edge, at the points directly underneath the laser receivers when the blade is level.
Dual sonic tracers* and Dual EM400s	The vertical guidance points are beyond the end of the cutting edge, at the point directly underneath the sonic tracer when the blade is level.

\*Sonic tracers cannot be used in linked mode.

The following figure shows a motor grader with dual laser receivers installed.

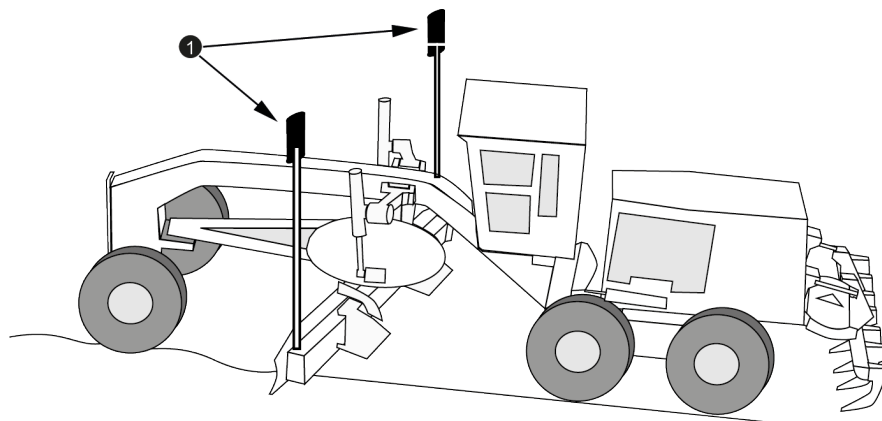

① Laser receivers

Figure 8.13 A typical linked lift-lift system

### Linked lift guidance views

The following figure shows the cross-section view guidance screen when the system is gathering linked lift-lift data.

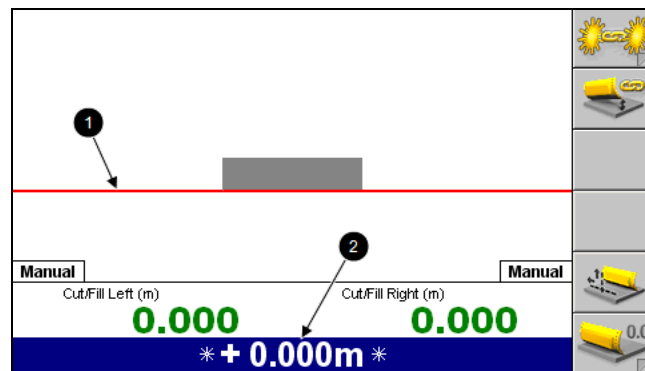

- ① Design surface                      ② Vertical offset

Figure 8.14 Linked lift-lift cross-section view

Points to note in [Figure 8.14](#):

- A laser receiver is providing lift guidance for both blade tips, indicated by the laser icon which appears on both the left and right side of the desired elevation value. If automatic controls were engaged, the system would drive both the *left* and *right* rams to correct any errors in the height of the left and right blade tips.
- The desired elevation of +0.000 m appears in the guidance settings area. This is based on the reference value chosen when the right hand lift sensor was benched. In this example, the right hand laser was given a reference elevation of 0 m when it was benched and no vertical offset has been added. For more information on benching lasers, refer to the *GCS900 Grade Control System Operator's Manual* for your machine type.
- The slope of the working surface is calculated using the cut/fill values measured at the vertical guidance points.

In addition to the cross-section view guidance screen, there are also two optional text guidance screens available when you use linked lift guidance.

### Linked lift lightbar information

When you use linked lift guidance, the light bars give guidance to both blade tips, and only the light bar corresponding to the tips is active. The horizontal light bar is off.

### 8.3 Sensor swap

The **Sensors** softkey (F1) enables you to cycle through all valid combinations of sensors connected to your motor grader or bulldozer. It allows you to select the appropriate configuration for the task you are performing. The **Sensors** softkey will display the sensors enabled at the time. For example,  laser lift guidance on the left blade tip while maintaining a constant cross slope.

By pressing and holding this softkey, you may directly select a sensor combination or disable sensor combinations that you do not want to use.

### 8.4 Automatic slope swap

Conventional guidance methods that monitor blade slope or cross slope support an automatic slope swap feature.

When you turn the automatic slope swap feature on, and set the automatic controls for the end of the blade controlled by slope to Manual, the system automatically changes the direction of the design slope to match the direction of the blade slope.

When you turn the automatic slope swap feature on, and set the automatic controls for the end of the blade controlled by slope to Auto, the system automatically changes the direction of the design slope to match the direction of the blade slope, when you change the end of the blade receiving slope guidance.

The direction of the cross slope reverses when the direction of the measured cross slope of the blade reverses. For example, if you are working a surface that is very close to a design cross slope of 2% down to the right, then the measured cross slope of the blade will be close to 2% down to the right (that is, the blade is very close to parallel with the design surface). When you reach the end of a pass, and put the controls in manual, and turn around, the measured cross slope of the blade is now close to 2% down to the left. If auto slope swap is turned on, the target cross slope setting will change to 2% down to the left.

This feature is most useful when you are doing final trimming of your surface in a machine equipped with automatic controls.

If automatic slope swap is turned off, the system displays the **Flip Target Slope** softkey  that enables you to swap the direction of the target slope manually.

### 8.5 Dip reduction (blade rotation compensation)

For conventional guidance systems that use a blade slope sensor, when a machine's blade is rotated while the system is operating under automatic control, then one end of the blade may over cut. For example, for a machine moving forward, rotating the

blade clockwise can result in the left hand end of the blade overcutting the design surface.

You can optionally use the dip reduction feature to compensate for this behavior.

## Excavator 2D Guidance Systems

### In this chapter:

- Introduction
- Depth guidance
- Depth-slope guidance
- Depth dual slope guidance
- Profile guidance
- Alignments with profiles
- Measure mode
- Establishing an elevation reference

This chapter describes the conventional (2D) guidance that an excavator system supports.

## 9.1 Introduction

An excavator system can support the following conventional guidance methods:

- Depth
- Depth-Slope
- Dual Slope (only available with a HS410 cab rotation sensor or GNSS Receiver Support)
- Profile
- Profiles with Alignments (only available with GNSS Receiver Support)

To switch between guidance methods, in the *Setup Menu – Configuration* menu, select *Guidance Method*. Press **Change Method** and select the guidance method that you require.

Excavator conventional guidance requires the following sensors:

- Bucket curl
- Stick angle or laser catcher
- Boom angle
- Pitch/roll
- VA boom angle (for machines with a VA boom)
- Tilt bucket angle (for machines with a tilt bucket)
- HS410 (only needed if you use Cab Rotation Support)
- MS972 Receiver (only needed if you use GNSS Receiver Support)

When the excavator uses a conventional guidance method, the left lightbar provides depth to grade guidance, and the right lightbar provides laser strike indication guidance (if a laser is configured).

## 9.2 Depth guidance

Depth guidance provides elevation and reach guidance to the excavator bucket. It is useful for the excavation of flat bottoms and basements, and for leveling work.

Depth guidance supports cab rotation, provided that the system is receiving machine pitch and roll information, and the design surface is flat.

For information on how to create depth memories, refer to the Operator's Manual for your machine.

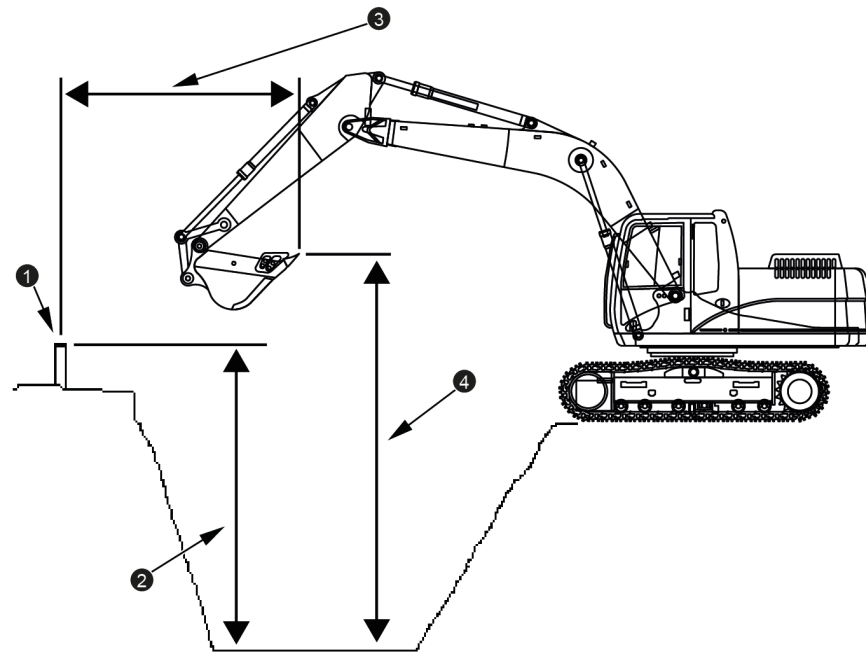

- ❶ Benchmark (0.0)
- ❷ Target depth
- ❸ Reported reach value
- ❹ Reported cut or fill value

Figure 9.1 Excavator Depth guidance

The following figure shows the split view guidance screen when the system is gathering depth guidance data.

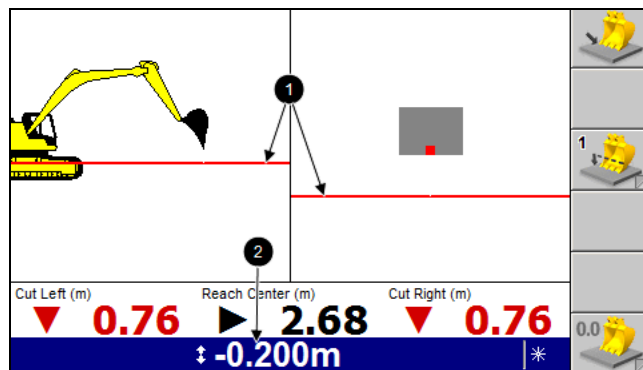

- ❶ Design surface
- ❷ Target depth

Figure 9.2 Depth guidance in split screen view

Points to note in [Figure 9.2](#):

- The target depth is 2 meters below the bench height.
- The center of the bucket is currently:
  - 0.76 meters above the target depth
  - 2.68 meters away from the benchmark

### 9.3 Depth-slope guidance

Depth-Slope guidance provides cut/fill and reach guidance to the excavator bucket, and also uses a target slope value. Reach and cut/fill guidance at the target slope is given relative to the benchmark.

Depth-Slope guidance enables the excavation of a simple slope, and does not support cab rotation.

For information on how to create depth or slope memories, refer to the Operator's Manual for your machine.

The following figure shows an example of a Depth-Slope guidance calculation.

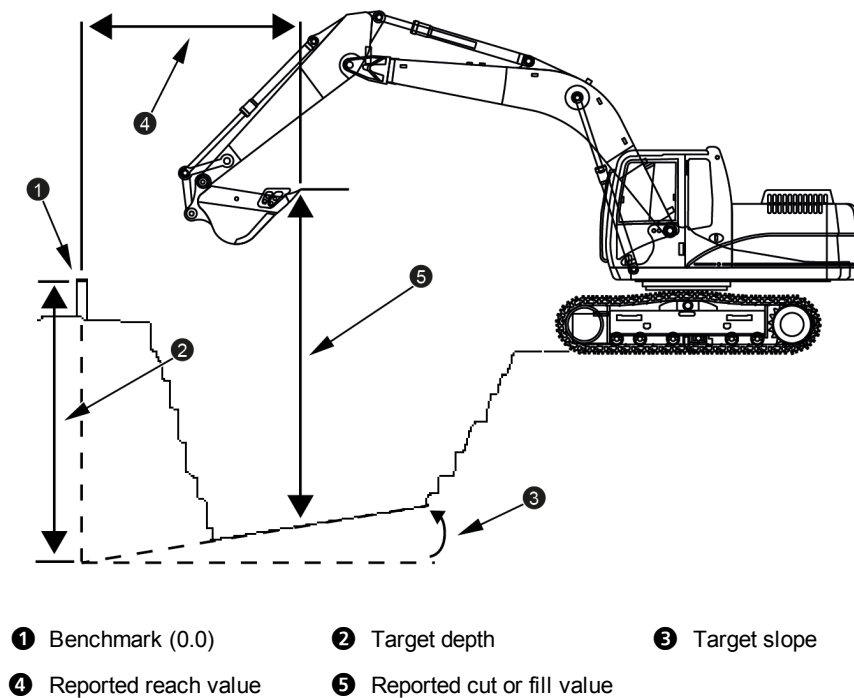
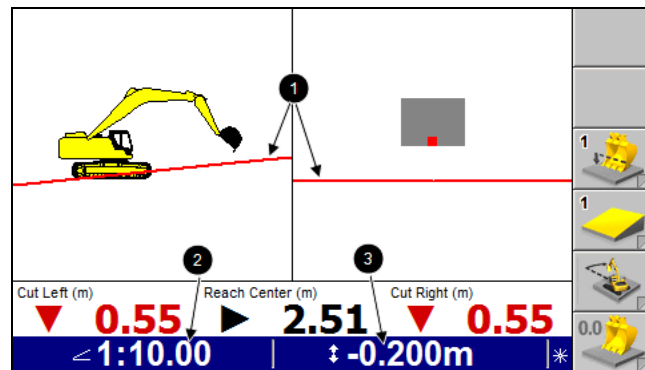

Figure 9.3 Depth-Slope guidance calculation



The following figure shows the split view guidance screen when the system is gathering Depth-Slope data.



- ① Design surface
- ② Target slope
- ③ Target depth

Figure 9.4 Depth-Slope split view guidance screen

Points to note in [Figure 9.4](#):

- The position of the focus point indicator on the bucket icon shows that the system is generating guidance for the center of the bucket.
- The target depth is 2 meters below the benchmark.
- The target slope is 1:10, rising away from the machine.

## 9.4 Depth dual slope guidance

Depth dual slope provides reach and elevation guidance to a dual slope (both grade and cross slope).

*Note* – *Depth dual slope is only available when an HS410 cab rotation sensor or GNSS Receiver Support is installed and configured.*

For information on how to create depth or dual slope memories, refer to the Operator's Manual for your machine.

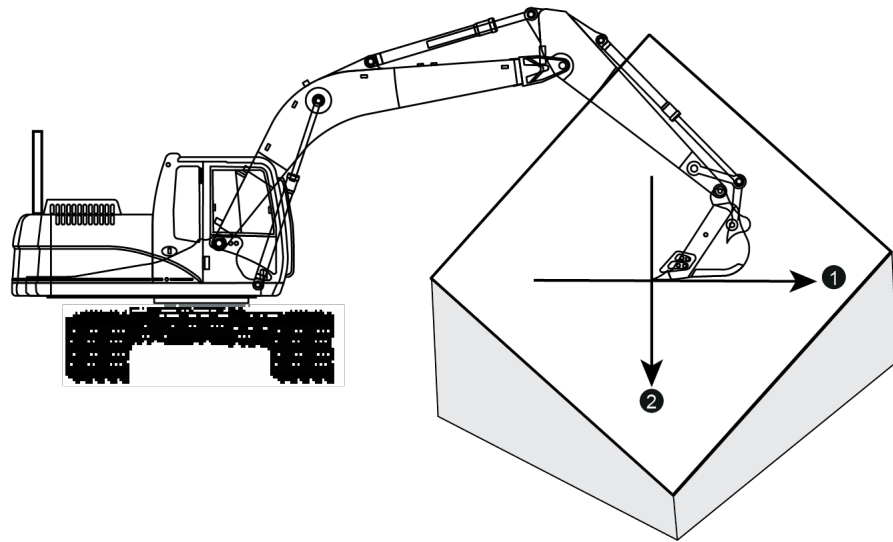

- ❶ Grade
- ❷ Cross slope

Figure 9.5 Depth dual slope guidance

The following figure shows the split view guidance screen when the system is gathering depth dual slope data.

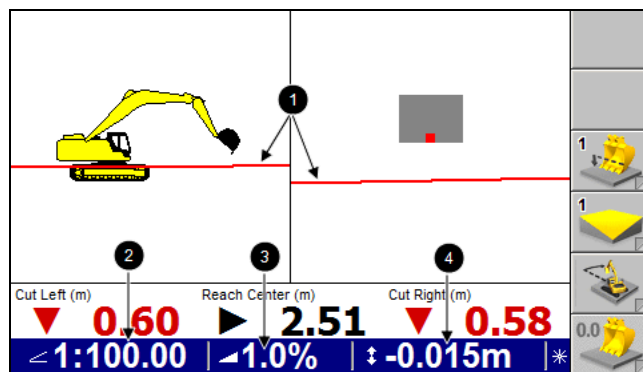

- ❶ Design surface
- ❷ Target grade
- ❸ Target cross slope
- ❹ Target depth

Figure 9.6 Depth dual slope split view guidance screen

Points to note in [Figure 9.6](#):

- The position of the focus point indicator on the bucket icon shows that the system is generating guidance for the center of the bucket.
- The target depth is 0.015 meters below the benchmark.

- The target grade is 1:100, rising away from the machine.
- The target cross slope is -1:100 (1.0%).

## 9.5 Profile guidance

Profile guidance enables you to excavate a pre-defined profile section with an unlimited number of reach and elevation points.

For information on how to create a profile or depth and slope memories, refer to the Operator's Manual for your machine.

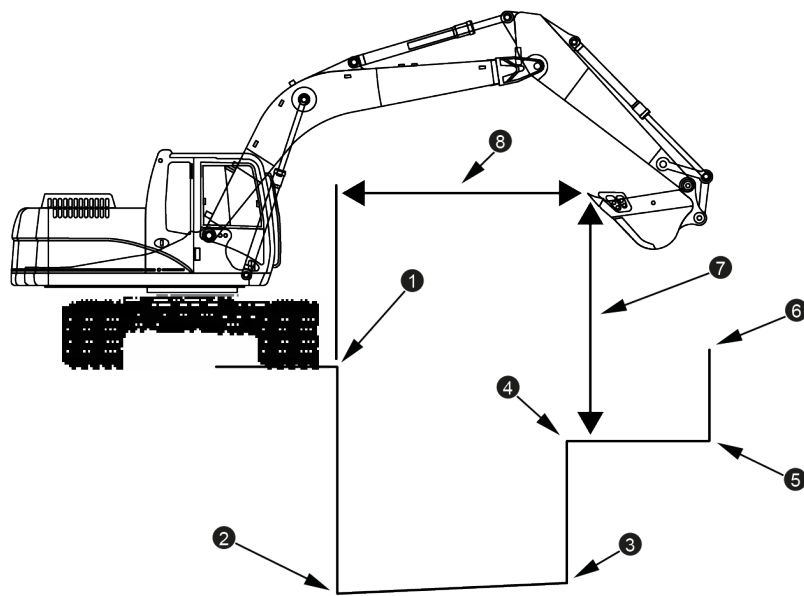

- |  |                  |           |
|--|------------------|-----------|
| ① Benchmark (0.0) and point 1 (origin) | ② Point 2        | ③ Point 3 |
| ④ Point 4                              | ⑤ Point 5        | ⑥ Point 6 |
| ⑦ Reported cut or fill                 | ⑧ Reported reach |           |

Figure 9.7 Profile guidance

The following figure shows the split view guidance screen when the system is gathering Profile data.

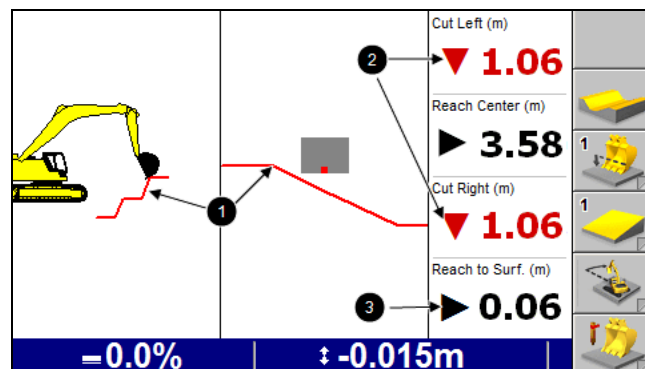

- ① Design surface
- ② Cut value to surface directly below bucket teeth
- ③ Distance to nearest point horizontally on the design surface - Reach to Surface

Figure 9.8 Profile split view guidance screen

Points to note in [Figure 9.8](#):

- The bucket is currently 1.06 meters away from the target depth.
- The bucket is currently 0.06 meters away from the closest point on the design surface, horizontally, to the bucket.

## 9.6 Alignments with profiles

**Note** – *Alignments with Profiles is only available when GNSS Receiver Support is installed and configured.*

Alignments with Profiles is flexible and versatile and is useful for the excavation of channels, trenches and carriage ways.

Alignments with Profiles guidance provides elevation and slope guidance to an alignment and profile. It allows you to create an alignment in the field and then attach a profile at right angles to the alignment. For example, to dig a drainage type ditch that does not go in a straight line.

**Note** – *By default, profiles are always applied to the right of the alignment. In the Select Profile dialog you can flip the profile to apply it to the left of the alignment.*

For information on how to create a profile, select an alignment or create depth memories, refer to the Operator's Manual for your machine.

The following figure shows an example of an Alignments with Profiles guidance calculation. The alignment is displayed as a dotted line. The profile is hinged onto

the alignment at its origin point resulting in an alignment with a cross section that matches the profile.

*Note* – The profile origin point to hang onto the alignment can be changed in the *Select Profile* dialog.

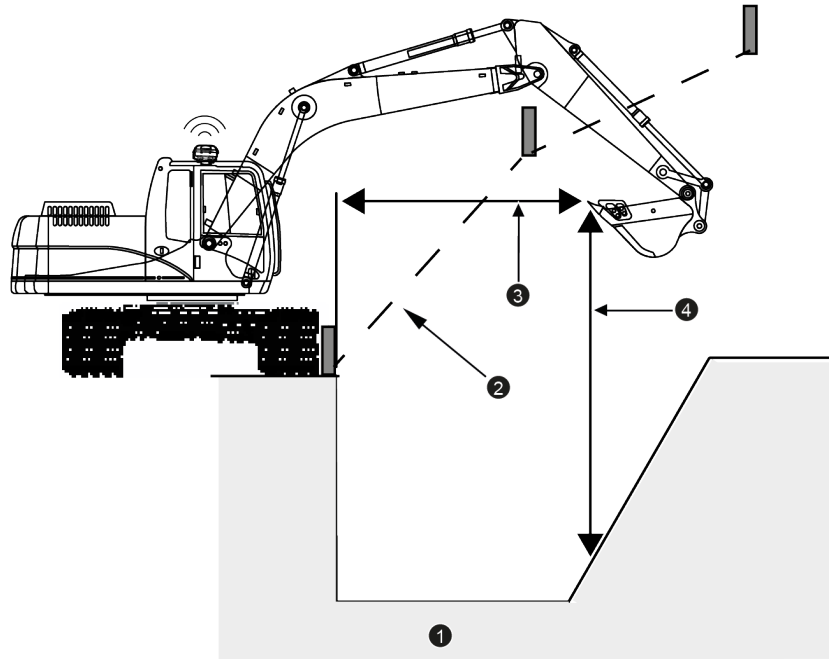

- ❶ Profile
- ❷ Alignment
- ❸ Reported reach
- ❹ Reported cut or fill

Figure 9.9 Alignments with Profiles guidance

The following figure shows the split view guidance screen when the system is gathering Alignments with Profiles data.

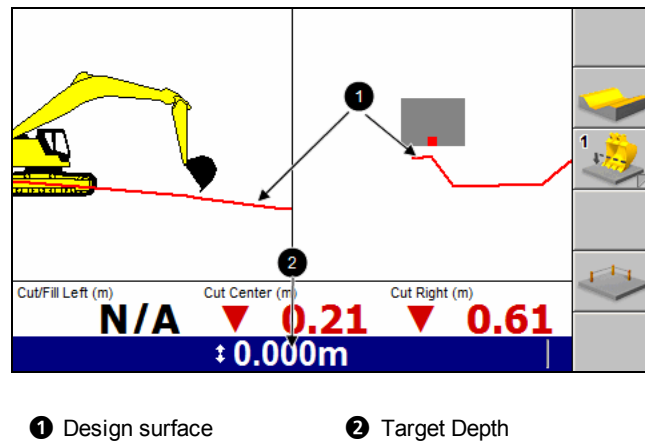

Figure 9.10 Alignment with Profiles split view guidance screen

Points to note in [Figure 9.10](#):

- The position of the focus point indicator on the bucket icon shows that the system is generating guidance for the center of the bucket.
- The target depth is 0 meters (same height as the benchmark).

## 9.7 Measure mode

*Note – Measure mode is not available when GNSS Receiver Support is enabled on a 2D Excavator system.*

Measure mode enables the operator to measure the distance and slope between two points.

The operator places the bucket cutting edge over an initial point and from then on the system displays any deviation from this point in terms of horizontal reach, elevation and slope.

Measure mode does not support cab rotation. The orientation of the excavator arm must be consistent when you take any measurements.

## 9.8 Establishing an elevation reference

An elevation reference is the zero point for reach and elevation. You can use either of the following as an elevation reference:

- A laser plane
- A benchmark

### 9.8.1 Elevation from a laser plane

When you use the system to establish an elevation reference from a laser plane, and calculate the target depth directly from the laser, this is known as depth from laser. To use depth from laser, you must:

- set up a laser transmitter
- enable the laser catcher on your machine
- make sure the system:
  - is not benched
  - can accept laser strikes

The following figure shows how the system calculates elevation guidance as an offset from the height of the laser plane.

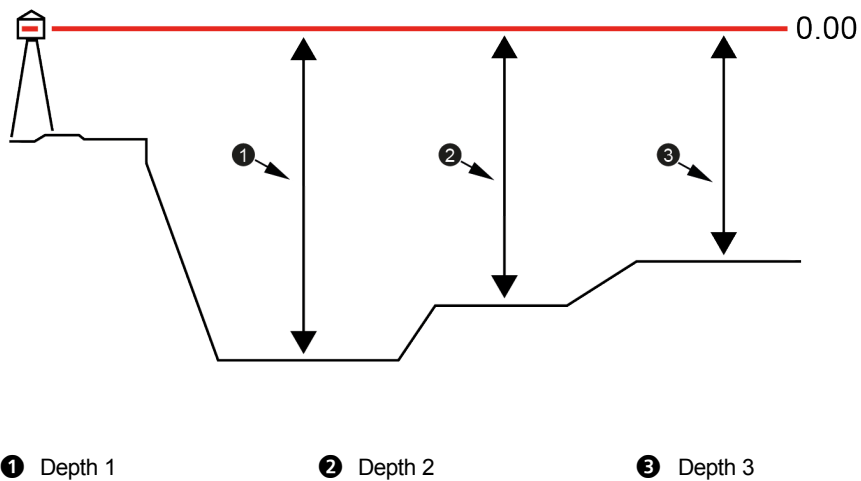

Figure 9.11 Depth from laser

## 9.8.2 Elevation from a benchmark

To establish an elevation reference from a benchmark, you must bench the bucket focus point over a location with known elevation.

As you move around the site, you will need to transfer the benchmark elevation. There are three ways of doing this:

- Laser referencing
- Touch-Point
- 3D positioning of the machine relative to a benched point (this is only available when GNSS Receiver Support is installed and configured)

### Laser referencing

If you use Depth or Depth Slope guidance with an enabled laser catcher, you can use the laser catcher to transfer bench information from one location to another. After you have benched the system, and have a laser reference relative to the bench point, you can move the machine to a different operating location, as shown in the following figure.

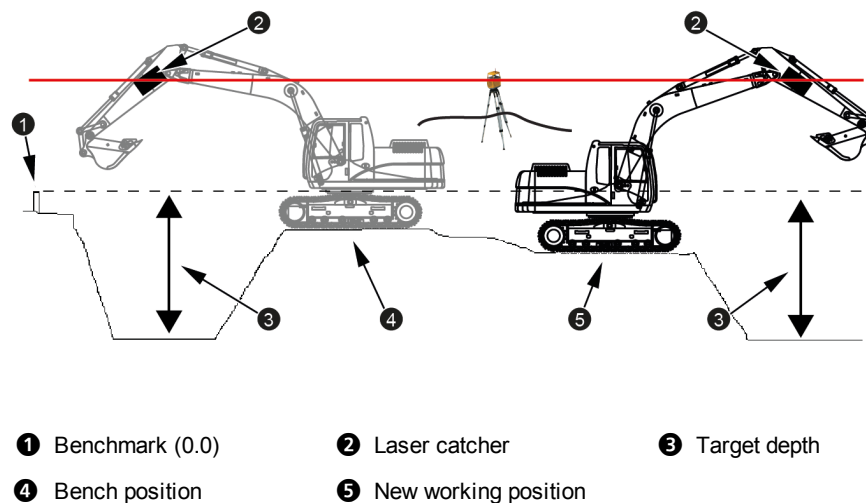

Figure 9.12 Laser referencing

### Touch-Point

If you use Depth or Depth Slope guidance without a laser catcher, you can use Touch-Point to transfer the elevation reference from one location to another. Touch-Point is only available after you have benched the system and requires a common feature, such as a rock, that you can easily access from both locations. Using



Touch-Point transfers the zero (bench) depth from one working location to another, as shown in the following figure.

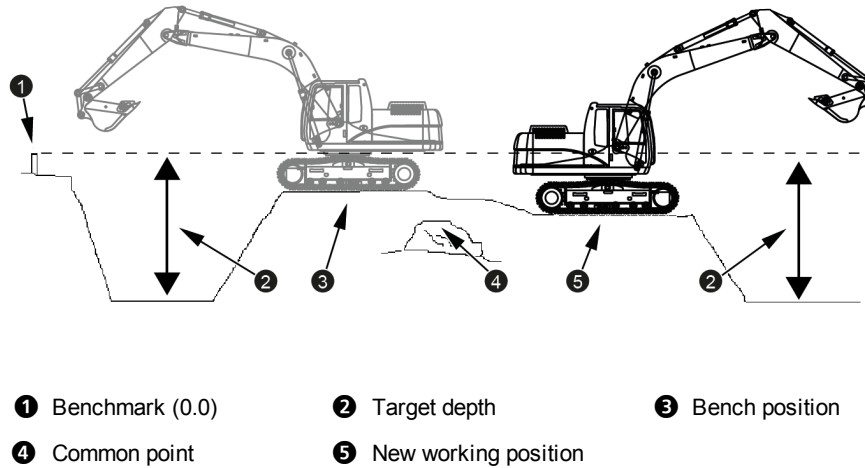
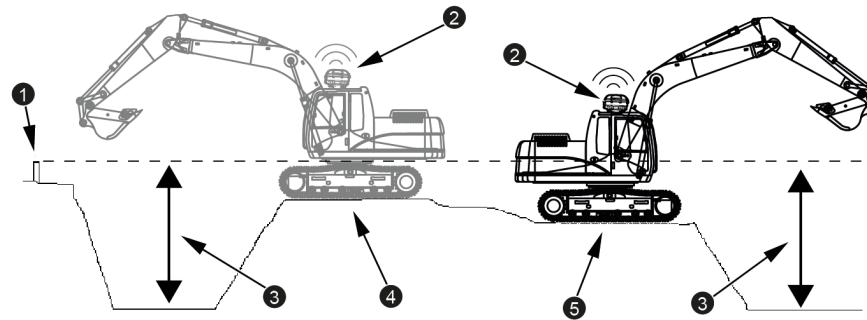

Figure 9.13 Laser referencing

**Note** – When using *Depth Slope* guidance, you cannot rotate the cab to reach the *Touch-Point* location. You must reach the *Touch-Point* in the digging orientation of the excavator arm.

### 3D positioning relative to a benched point

If you use *Depth* or *Depth Slope* guidance with GNSS Receiver Support, you can use 3D positioning relative to the benched point. After you have benched the system, and have GNSS coverage, you can move the machine to a different operating location, as shown in the following figure. This eliminates the need to catch lasers or do touch points to transfer elevation around the site.



- ❶ Benchmark (0.0)
- ❷ GNSS MS9x2 receiver
- ❸ Target depth
- ❹ Bench position
- ❺ New working position

---

Figure 9.14 GNSS Receiver Support

## 3D Guidance Systems

### In this chapter:

- Introduction
- Overview of 3D guidance
- 3D design files
- 3D guidance surfaces
- Lane guidance
- 3D guidance sensors
- 3D guidance methods
- Switching between conventional and 3D guidance systems
- Cut adjustment
- Horizontal guidance
- Machine orientation and pitch

This chapter describes the 3D guidance features of the GCS900 Grade Control System.

## 10.1 Introduction

3D guidance uses the three dimensional coordinates of the machine to provide cutting edge guidance relative to a three dimensional digital design. 3D systems can provide both vertical and horizontal guidance, and is useful for constructing complex designs, such as highways and curved banks.

## 10.2 Overview of 3D guidance

To calculate the cut and fill corrections for each blade tip that uses 3D guidance, the system generates a guidance plane under the blade which has a mainfall and cross slope that very closely approximates those of the working surface.

The system can determine the cross slope of the guidance plane by calculating the cross slope of:

- the working surface at a position directly below or above a single vertical guidance point on the cutting edge
- a line joining the two points on the working surface below or above two vertical guidance points on the cutting edge

The method of calculating the cross slope is referred to as the vertical guidance method. The different vertical guidance methods provide flexible cutting edge guidance that enables you to:

- hang the blade tip over the crown of a road without cutting the crown off
- hang the blade tip over the side slope (batter) without incorrectly raising or lowering the vertical guidance to the road surface
- cut narrow ditches that are smaller than your blade
- for irregular design surfaces, create a smooth cut with the blade

3D guidance systems can also provide horizontal guidance. The horizontal equivalent of a vertical guidance point is called the focus point. There is only one active focus point on the cutting edge, either at the left or right tip of the blade.

## 10.3 3D design files

3D guidance systems use a design file loaded into the CB4x0 control box system memory from a USB flash drive.

For information on lane guidance, the surface guidance feature for SVD/SVL designs, see [10.5 Lane guidance](#).

When a design file loads, the:

- Plan view guidance screen appears
- Vertical lightbars are lit to provide guidance to the design surface
- The **Offsets** softkey  is available
- *Select Design* item in the *Setup Menu – Configuration* menu displays the name of the design
- *Vertical Offset* and *Horizontal Offset* items in the *Setup Menu – Configuration* menu are available

If a design is not loaded:

- All the LEDs on all the lightbars are off
- In the text views screens, **N/A** appears as the value of guidance parameters
- Cross-section view displays a **No Design Loaded** message

If you turn off the system while a design is loaded, when you power up again, the system attempts to reload the same design.

In addition to defining a design surface, design files can also provide the following information:

- Avoidance zones
- On-screen linework

### 10.3.1 Avoidance zones

Avoidance zones are designated areas that you must keep away from. Avoidance zones can be site-wide, or they can be specific to a particular design.

The system provides avoidance zone proximity detection:

- for machines with rippers
  - at the front of the machine to the width of the blade
  - at the rear of the machine to the length of the ripper
- for all other machines with blades
  - at the front and rear of the machine to the width of the blade
- for excavators
  - at the front of the machine to the width of the bucket tips
  - at the rear of the machine to the width of the antenna positions

### Site-wide avoidance zones

When the system is turned on, if there is a site avoidance zone file in the root folder of the system memory, then the file is automatically loaded and displayed in the plan view guidance screen. The system provides site avoidance zone proximity detection until the control box is turned off.

*Note – If the site avoidance zone file cannot load, the control box turns off. Contact your site supervisor immediately.*

### Design avoidance zones

Design avoidance zones are specific to a design surface. The design avoidance zones load from the system memory as the design loads.

The design avoidance zones appear in the plan view guidance screen. The system provides proximity detection while the design surface remains loaded.

*Note – If the design avoidance zone cannot load, the selected design does not load. To continue, select an alternative design surface. Contact your site supervisor immediately.*

### Warning levels

As the machine approaches an avoidance zone, three levels of warning are used:

*Note – Your site supervisor sets the avoidance zone warning distance. This distance can vary with the selected machine type. Ask what it is set to for your machine.*

- If you are within three times the warning distance, the following warnings occur:
  - The avoidance zones turn magenta.
  - If configured, the *Avoid. Dist.* text item shows the distance and direction to the closest avoidance zone boundary.

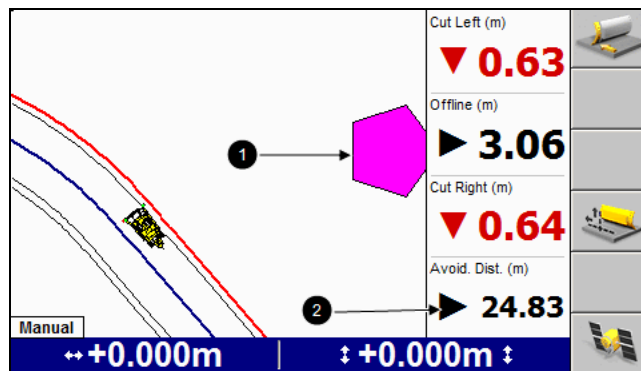

- ① Avoidance zone shown in magenta      ② Avoidance distance displays

Figure 10.1 First level of avoidance zone warning

- Once you are inside the configured warning distance, the following additional warnings occur:
  - In the plan view guidance screen, a warning symbol flashes on the machine icon.
  - The *Avoid* indicator appears to the right side of the status bar.
  - The beeper sounds three times.

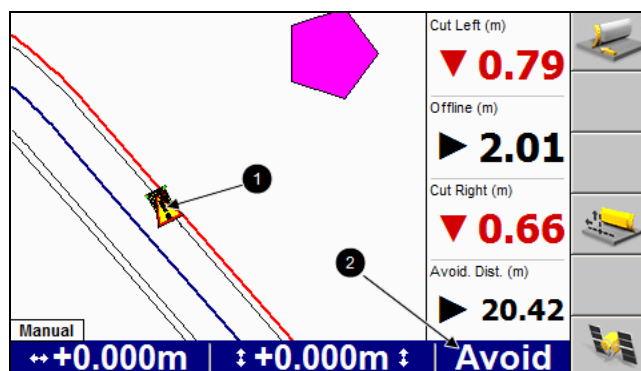

- ① Flashing warning symbol      ② *Avoid* indicator

Figure 10.2 Second level of avoidance zone warning

- If you enter the avoidance zone:
  - A flashing message **Avoidance Zone Entered** appears on a yellow background. The message appears in all guidance screens.
  - Constant beeping sounds until you exit the avoidance zone.
  - The *Avoid. Dist.* text item shows a negative value.

- The location where your machine entered and exited the avoidance zone is recorded in the program log.

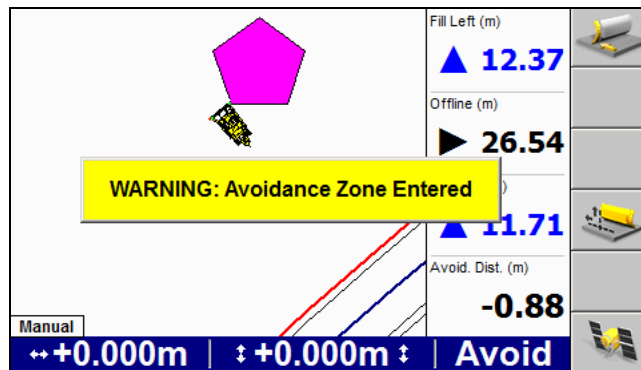

### No avoidance zone guidance

The system does not provide avoidance zone guidance when any of the following messages appear:

- **Very Low Accuracy (GNSS)**
- **Old Position**
- **No GNSS Data (Left) or (Right) or (Center)**
- **No UTS Data**
- **Check UTS Radio**
- **Check Machine Radio**
- **Option Not Installed**
- **Check Machine Type**
- **Check Machine Measurements**
- **Adjust Bolt Hole**
- **Check UTS Battery**
- **Level UTS and Check UTS Setup**
- **Search For Machine Target**
- **Quick Searching ...**
- **Full Searching ...**

If any of the above messages appear, the following warnings are activated:

- The **No Avoid** indicator appears on the status bar.
- The *Avoid. Dist.* text item, if configured, appears as **N/A**.



If the **Direction Unknown** message appears, you are warned as you approach or enter an avoidance zone, but the *Avoid. Dist.* text item, if configured, appears as **N/A**.

### Supported file types

Avoidance zones can be either \*.avoid.svl or \*.avoid.dxf files and must only contain **closed** polygons.

It is recommended that avoidance zones should be exported via the Machine Avoidance Zone exporter in Business Center – HCE. Business Center – HCE analyzes the files and allows only those containing closed polygons to be exported to either SCS900 or GCS900 Grade Control System.



---

CAUTION — Avoidance zone files which include linework which are not closed polygons will cause incorrect avoidance zone proximity detection and warnings.

---

Avoidance zones exported from Business Center – HCE to SCS900 are in a \*.avoid.dxf format, and can only be exported at the site level, not the design level.

It is not possible to export an avoidance zone in the field from SCS900 to GCS900 Grade Control System by using the *Export to GCS900 Grade Control System* option in SCS900.

### 10.3.2 On-screen linework

A design may include on-screen linework that includes the following background elements:

- Site map
- Background linework
- Design boundary
- Road alignments

You can select these background elements for horizontal guidance.

#### Site map

The site map provides an outline of the site. When a site map is present on the USB flash drive, you can transfer it to the control box's system memory. The site map information loads once it is in the system memory.

Site map information appears in the plan view guidance screen.

The following figure shows an example of a site map with the addition of background linework.

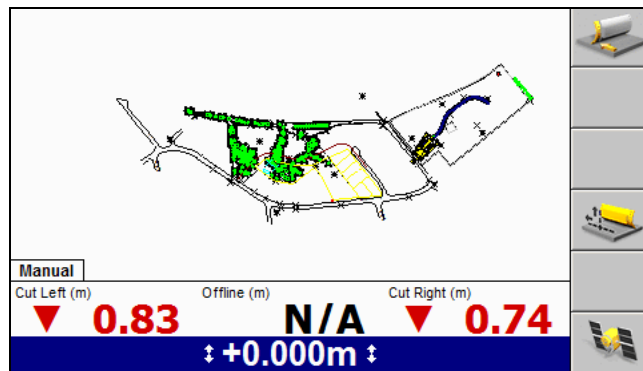

### Background linework

Background linework is similar to a site map, but background linework information loads and unloads with the selected design.

Background linework information is useful for showing perimeters and other areas of interest around the design surface. Background linework information appears in the plan view guidance screen.

The following figure shows an example of different types of background linework.

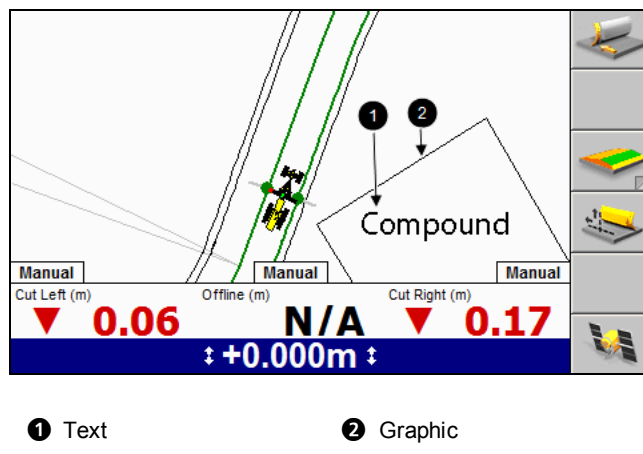

- ① Text
- ② Graphic

Figure 10.3 Example of background linework

### Design boundary

Most designs have a boundary which indicates the extents of the vertical guidance information. If you move outside the design boundary, vertical guidance stops. The plan view guidance screen uses gray linework to display design boundaries.

The following figure shows an example of a design with a boundary.

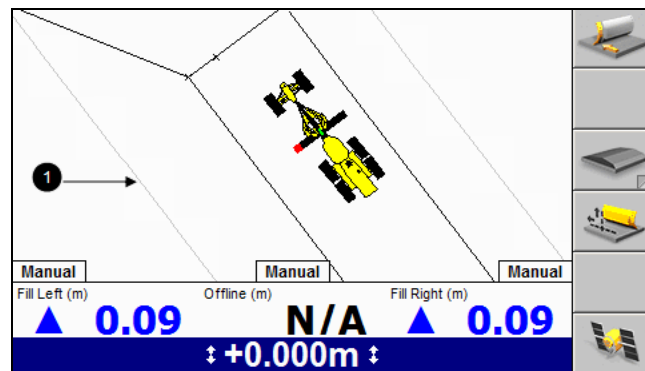

① Design boundary

Figure 10.4 Example of a design boundary

If the current blade position (at the blade focus) is not within the design boundary:

- The LEDs at each end of the relevant vertical lightbar flash repeatedly
- All guidance text items appear as **N/A**

If both blade tips are outside the design boundary:

- In cross-section view, the screen is blank except for the error message **Off Design No cross-section available.**
- In profile view, the screen is blank except for the error message **Off Design No profile available.**

*Note – Surface design files can have holes or gaps (such as lakes) in them, and there can be valid areas of guidance within the gaps (such as islands).*

### Road alignments

Road design files (.dc files) can specify road features such as shoulder alignments, in addition to the master alignment of the road. The master alignment and any additional alignments are shown in both the plan view and cross-section view guidance screens.

The following figure shows a plan view of a road design.

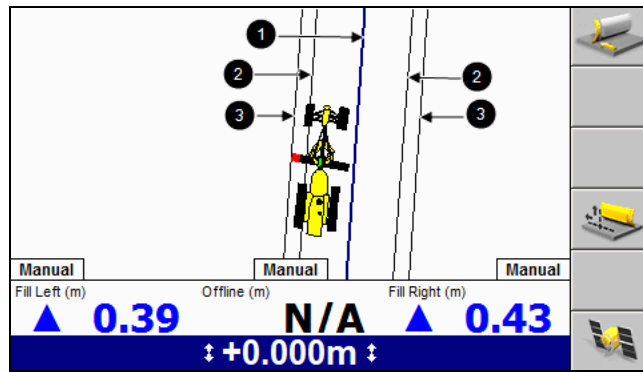

- ❶ Master alignment
- ❷ Shoulder
- ❸ Other alignments

Figure 10.5 Example of road alignments in the plan view guidance screen

The following figure shows a cross-section view of a road design.

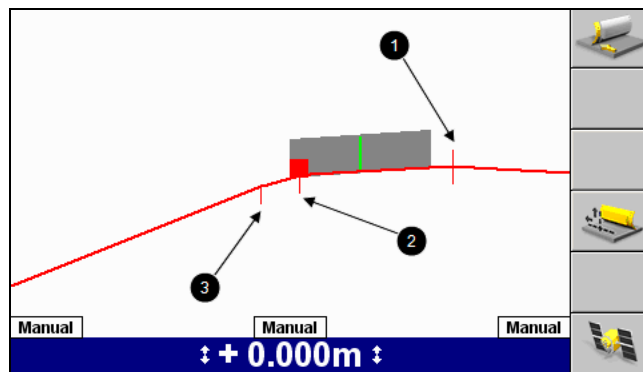

- ❶ Master alignment
- ❷ Shoulder
- ❸ Other alignment

Figure 10.6 Example of road alignments in the cross-section view guidance screen

## 10.4 3D guidance surfaces

3D guidance systems enable you to specify surfaces, other than the final design surface, that provide a source of vertical guidance information. These are called working surfaces, which you can use as intermediate surfaces between the current ground surface and the final design surface.

Depending on the type of design, the following working surfaces are available in addition to the design surface:

- Reference surfaces
- Layered lifts
- Perpendicular lifts
- Vertical lifts

The following color conventions are used to display design and working surfaces in cross section and profiles views:

- The design surface appears as a light gray line.
- The working surface appears as a red line.

As with design surfaces, you can apply temporary offsets to working surfaces. In this case the following color conventions are used in cross section and profiles views:

- The design surface appears as a light gray line.
- The working surface appears as a black line.
- The temporary working surface, created by the application of the offset to the working surface, appears as a red line.



**Tip** – In all cases, guidance is given to, and automatic controls attempt to cut to, the surface indicated by the red linework.

#### 10.4.1 Reference surfaces

Road (\*.dc) designs may include reference surfaces when the finished surface is built up of a number of layers. For example, a road surface might be built up from four or five layers, made up of different grades of material. When preparing the road design, the engineer can use a reference surface to specify the finished level of each layer.

A design may contain any number of reference surfaces. Reference surface names are assigned in SiteVision Office.

The following figure shows a road design with a reference surface selected as the working surface.

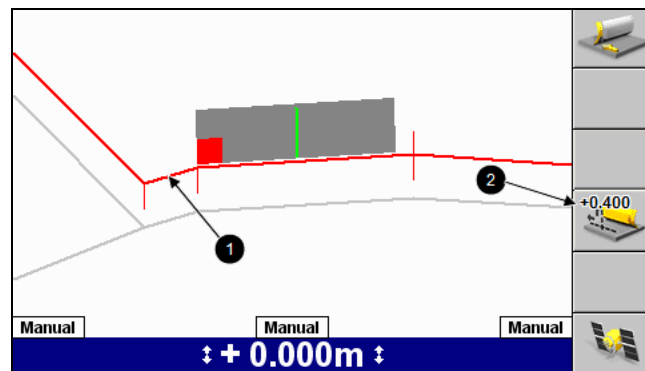

- ① Reference surface (working surface)      ② Height of reference surface

Figure 10.7 Cross-section view with a reference surface as the working surface

The **Vertical Offset: Reference Surface** softkey  indicates the height of the reference surface, shown in the previous figure as  $+0.400$ .

#### 10.4.2 Layered lifts

The system uses a layered lift to define a working surface relative to a currently loaded road design. Layered lifts are only available when a road design (\*.dc) file is loaded.

The layered lift feature enables the operator to build a road to the full width of the side slopes (batters) in lifts of a specified thickness. Layered lifts are useful when building up large fills or cutting down cuttings.

The system calculates the layered lift according to the type of road design file. There are two types of road design file:

- Standard layered lift. Standard layered lift designs have any number of horizontal alignments; the layered lift is applied to the master alignment.
- Dynamic layered lift. Dynamic layered lift designs are only available when the following combinations of design file formats are exported from SiteVision Office V7.1, or later, as .dc road designs:
  - \*.yxz and \*.040 files
  - \*.001 and \*.040 files
  - \*.GP2 and \*.040 files
  - \*.066 and \*.040 files

There are two types of dynamic layered lift designs:

- Single slope. Single slope dynamic layered lift designs have any number of horizontal alignments; the layered lift is applied to second and second last alignments.
- Dual slope. Dual slope dynamic layered lift designs have five horizontal alignments. The layered lift is applied to the center alignment.

### Standard layered lift

The system creates a layered lift for a standard design file in the following way:

1. The value that is entered as the displacement of the layered lift from the design surface is used to raise or lower the master alignment of the road, as shown below.

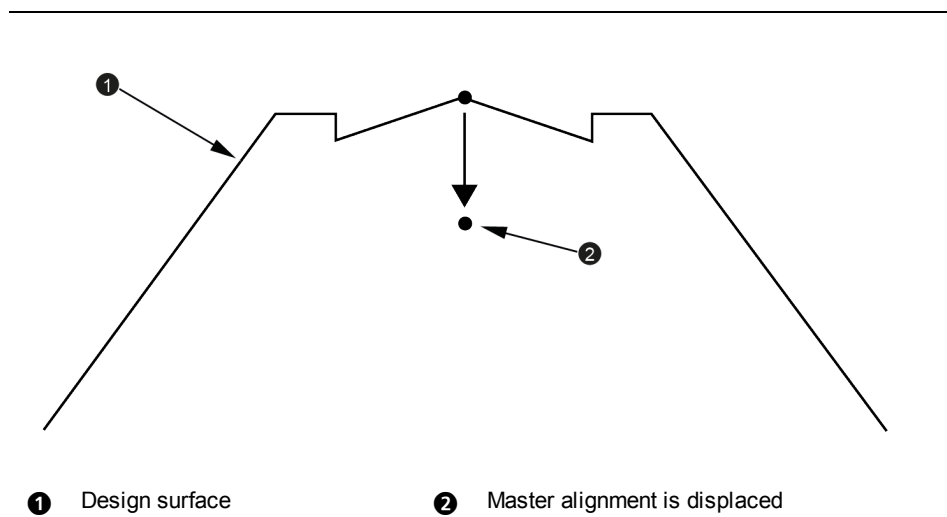

Figure 10.8 Master alignment displaced, in this case downward

2. The first non-vertical design elements on the left and right sides of the master alignment are extended until the original design surface is intersected. The following figure shows a case where the road surface needs to be built up, that is when the side slope of the design is set to *Fill*. In this case, the layered lift displacement will be negative.

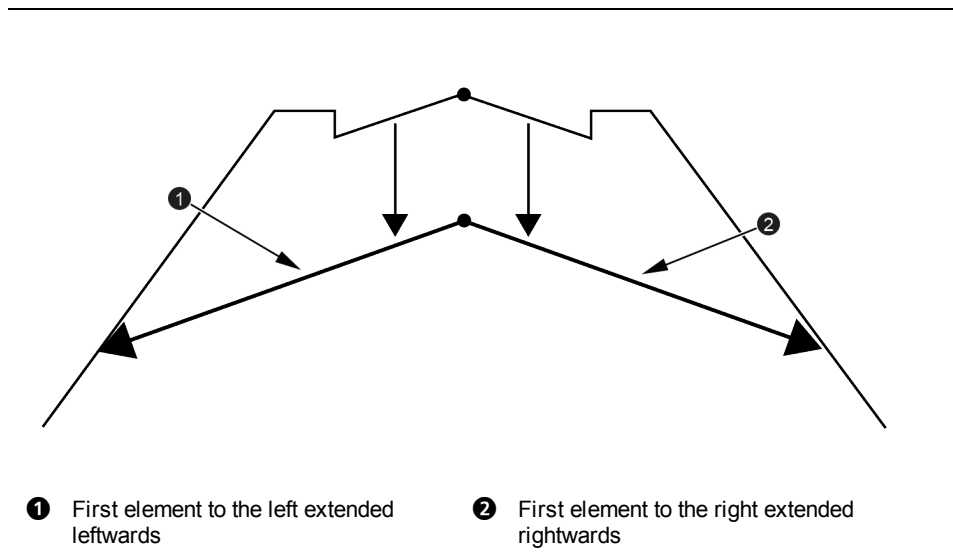

Figure 10.9 First non-vertical elements extended

The surface created by extending the design elements in this way creates the working surface shown in the following figure.

---

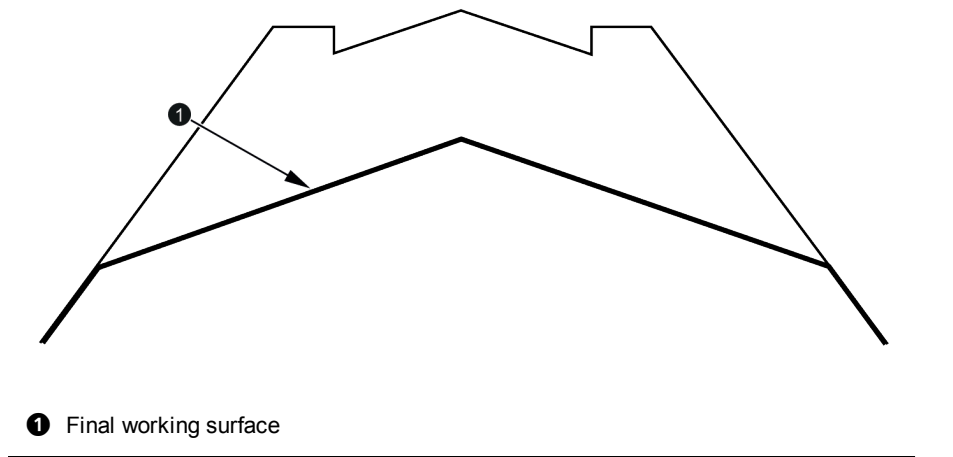
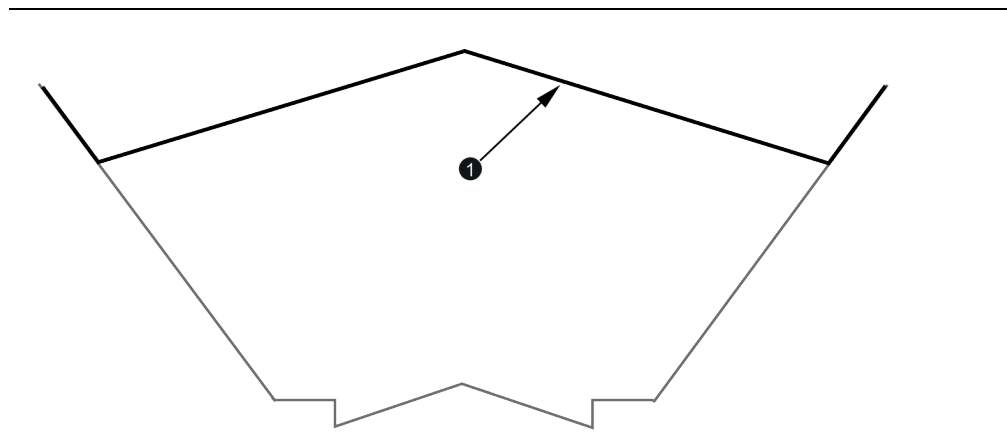

Figure 10.10 Layered lift working surface - filling towards the design surface

When you are cutting down to the road surface, the process is similar except that the layered lift is displaced above (that is, with a positive value) the design surface, as shown in the following figure.





❶ Final working surface

Figure 10.11 Layered lift working surface - cutting towards the design surface

The cross slope of the elements left and right of the master alignment is maintained through superelevated areas or other changes to the cross slope.

Horizontal guidance is available to the intersection of the layered lift surface and the original design surface.

The following figure shows a road design with a layered lift as the working surface, as displayed in the cross-section view guidance screen.

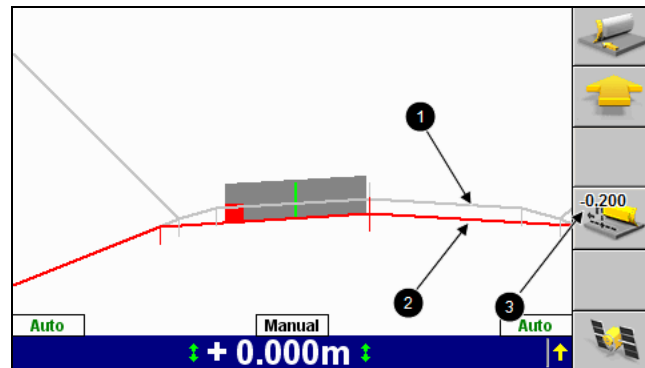

❶ Design surface

❷ Working surface

❸ Lift offset value

Figure 10.12 Cross-section view of a road design with a layered lift as the working surface

### Single slope dynamic layered lift

The system creates a single slope dynamic layered lift in the following way:

1. The value that is entered as the displacement of the layered lift from the design surface is used to raise or lower the second and second last cross section element, as shown in the following figure. In this case, the layered lift displacement is negative.

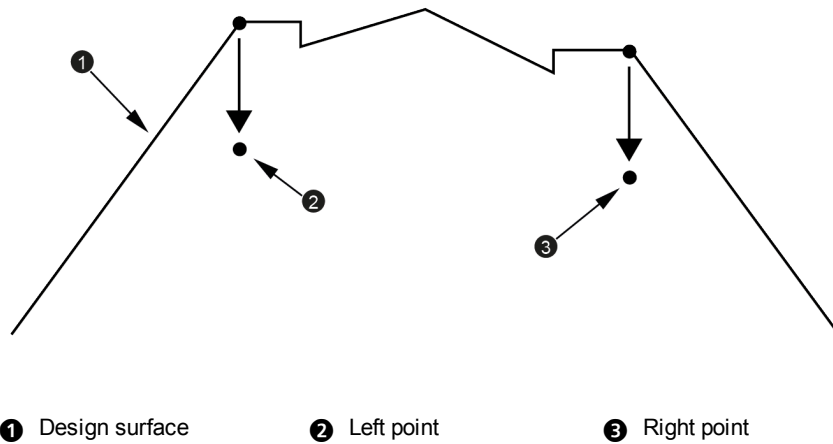

Figure 10.13 Alignments lowered

2. A line is drawn between the second and second last cross section elements until the original design surface is intersected, as shown in the following figure.

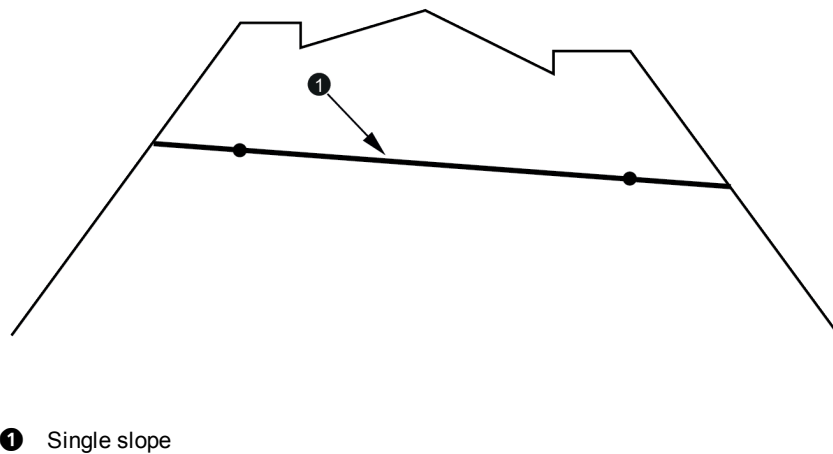
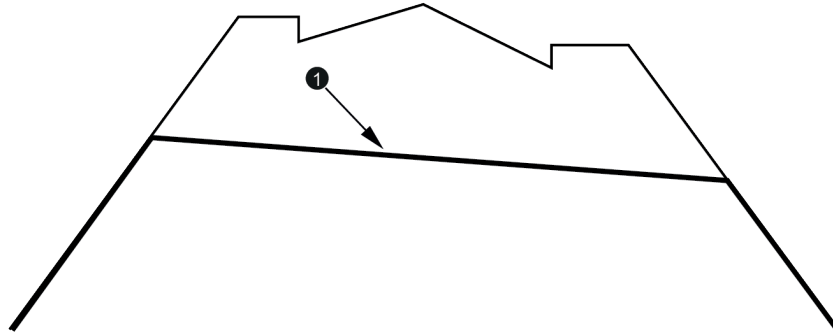

Figure 10.14 Single slope created

3. The surface created by drawing a line between these design elements creates the working surface shown in the following figure.



① Final working surface

Figure 10.15 Single slope layered lift working surface - filling towards the design surface

When you are cutting down to the road surface, the process is similar except that the layered lift is displaced above (that is, with a positive value) the design surface, as shown in the following figure.

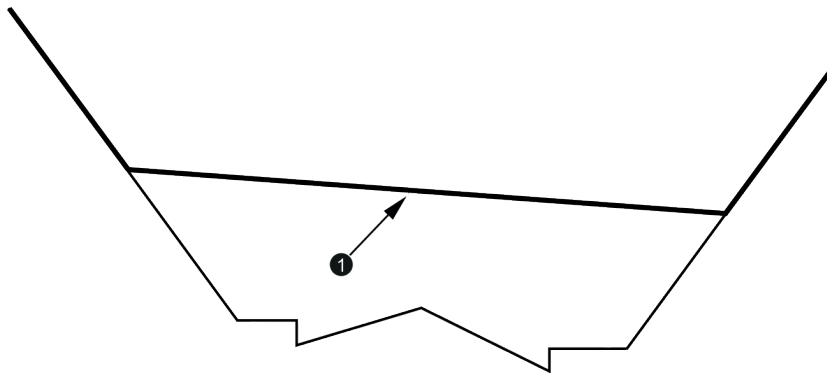

① Working surface

Figure 10.16 Single slope layered lift working surface - cutting towards the design surface

The cross slope of the second and second last element is maintained through superelevated areas or other changes to the cross slope.

Horizontal guidance is available to the intersection of the layered lift surface and the original design surface.

The following figure shows a road design with a single slope layered lift as the working surface as displayed in the cross-section view guidance screen.

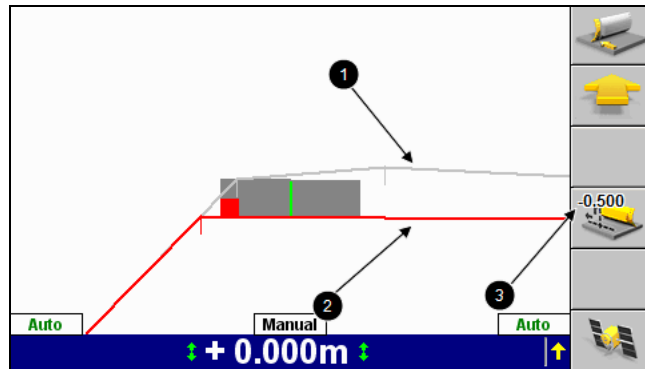

- ① Design surface
- ② Working surface
- ③ Lift offset

Figure 10.17 Cross-section view with a single slope dynamic layered lift as the working surface

### Dual slope dynamic layered lift

The system creates a dual slope dynamic layered lift in the following way:

1. The value that is entered as the displacement of the layered lift from the design surface is used to raise or lower the center alignment from the original design data as shown in the following figure.

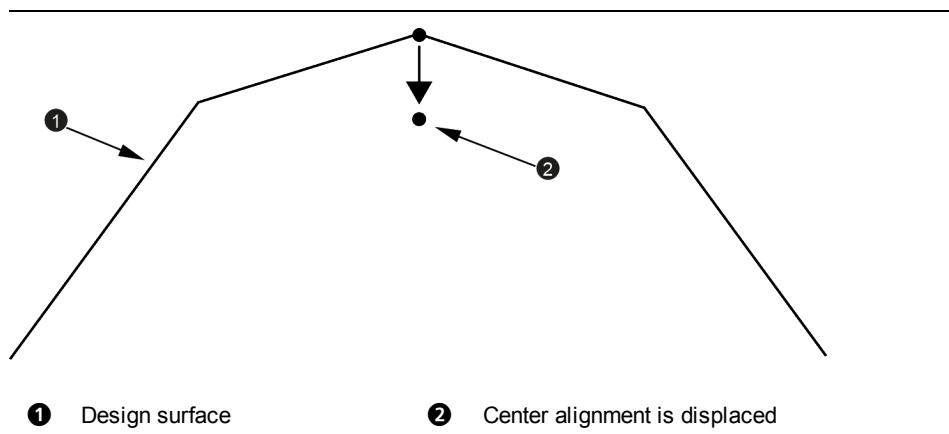

- ① Design surface
- ② Center alignment is displaced

Figure 10.18 Single cross slope alignment – lowered

2. The first design elements on the left and right sides of the master alignment are extended until the original design surface is intersected, as shown in the following figure. In this case, the layered lift displacement is negative.

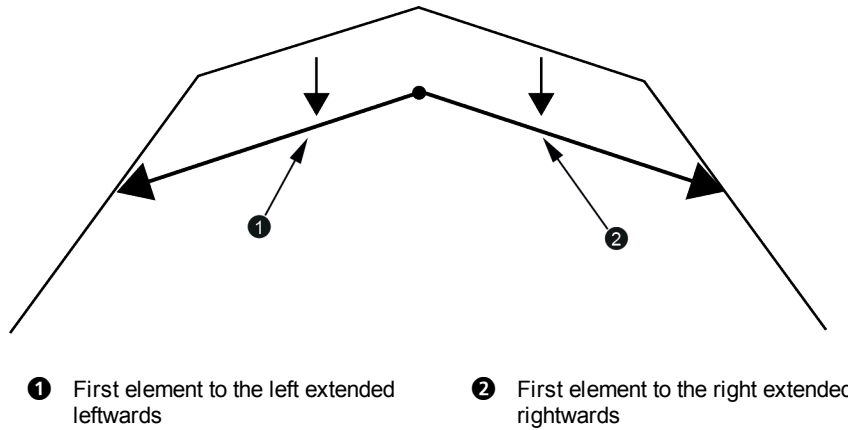

Figure 10.19 Left and right first design elements extended

3. The surface created by drawing a line between these design elements creates the working surface shown in the following figure.

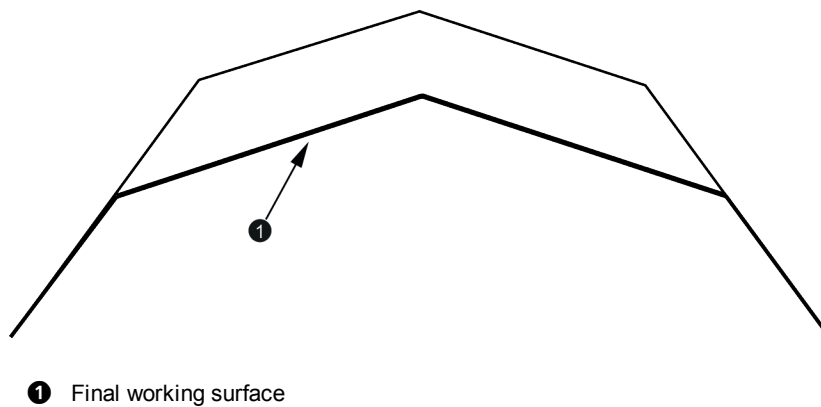
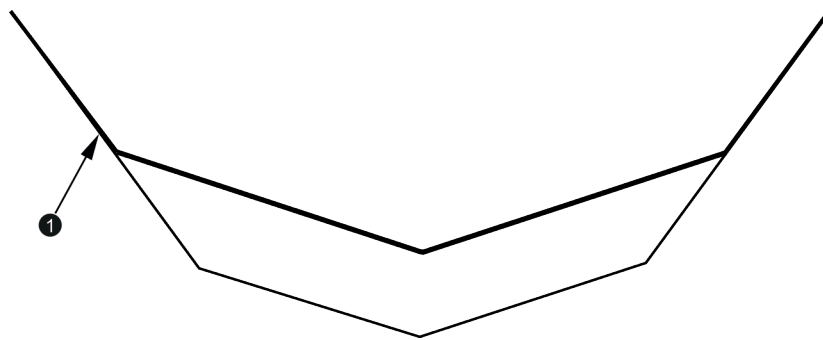

Figure 10.20 Dual slope layered lift working surface - filling towards the design surface

When you are cutting down to the road surface, the process is similar except that the layered lift is displaced above (that is, with a positive value) the design surface, as shown in the following figure.



① Working surface

Figure 10.21 Dual slope layered lift working surface - cutting towards the design surface

The cross slope of the elements left and right of the center alignment are maintained through superelevated areas or other changes to the cross slope.

Horizontal guidance is available to the intersection of the layered lift surface and the original design surface.

The following figure shows a road design with a layered lift working surface as displayed in the cross-section view guidance screen.

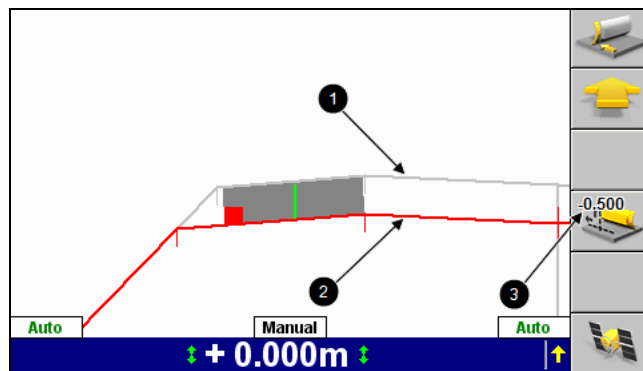

① Design surface                      ② Working surface  
 ③ Lift offset

Figure 10.22 Cross-section view with a dual slope dynamic layered lift as the working surface

### 10.4.3 Perpendicular lifts

Some applications require a constant thickness of material to be laid over a design surface. Using perpendicular lifts, the thickness of material is the same on sloping and flat sections of the design.

The following figure shows a cross-section of a perpendicular lift applied to a design surface.

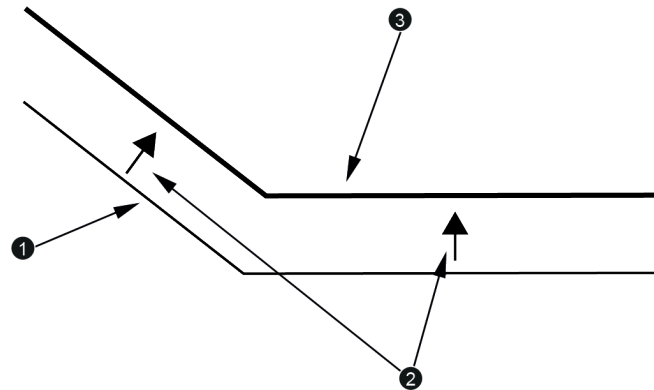

- ① Design surface      ② Offset perpendicular to design surface      ③ Working surface

Figure 10.23 Perpendicular lift

The following figure shows a road design with a perpendicular lift working surface as displayed in the cross-section view guidance screen.

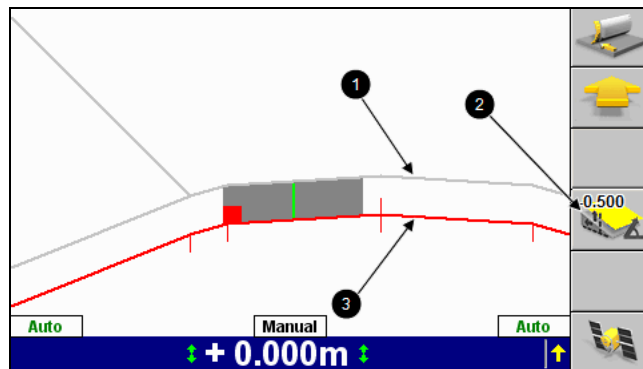

- ① Design surface      ② Lift offset value  
③ Working surface

Figure 10.24 Cross-section view with a perpendicular lift as the working surface

Perpendicular lifts are calculated dynamically, as shown in [Figure 10.25](#). The working surface (①) is calculated by identifying the point on the design surface (②) directly below the vertical guidance point on the cutting edge (③) and applying the lift distance at right angles to the design surface at that point (④). Each time the machine passes over a point where the design changes in slope (an inflection point) the working surface is recalculated. For this reason, for large lift values and large

slope differences, the working surface *may appear* to change as the machine moves across an inflection point.

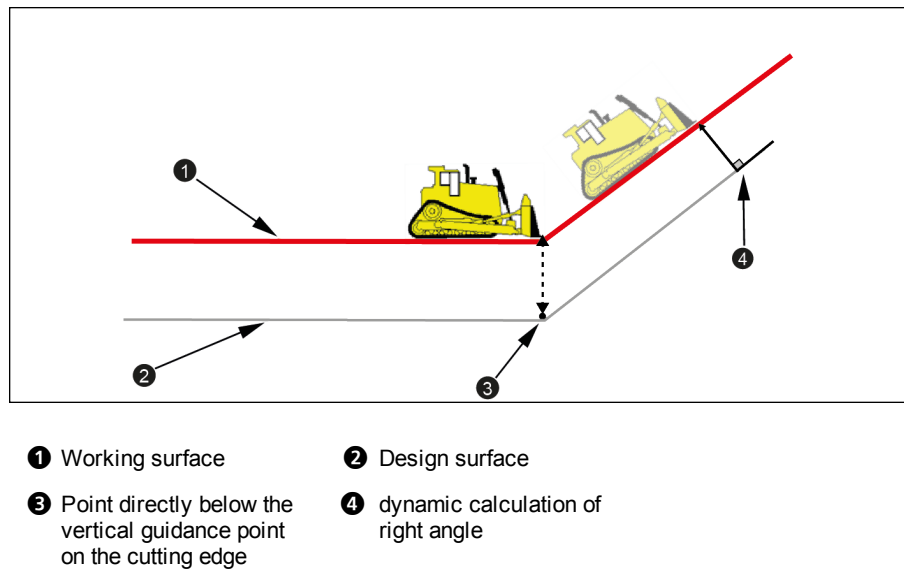

Figure 10.25 Dynamic calculation of perpendicular lift

#### 10.4.4 Vertical lifts

A vertical lift is almost the same as a vertical offset. A vertical lift is used to specify large offsets, while a vertical offset is better for small, temporary offsets.

Vertical lifts are useful when the design requires bulk cut or fill. The design can be cut away or built up in stages by working to different vertical lift surfaces until the site approaches the final design surface. When the site is close to design, a vertical offset can be applied to the original design surface.

The following figure shows a cross-section view with a vertical lift applied to a design consisting of level and sloping surfaces. The thickness of material is less on the sloping surface than on the level surface.



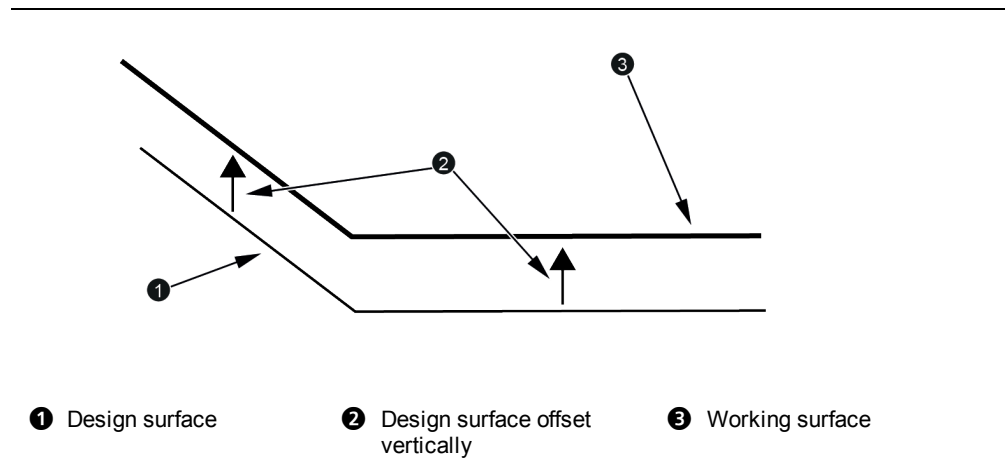

Figure 10.26 Vertical lift

The following figure shows a road design with a vertical lift working surface as displayed in the cross-section view guidance screen.

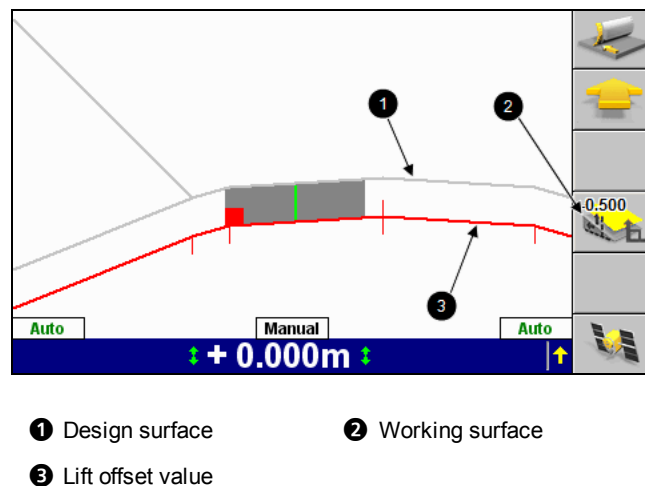

Figure 10.27 Cross-section view with a vertical lift as the working surface

## 10.5 Lane guidance

Lane guidance is a surface guidance feature for SVD/SVL designs. When lane guidance is selected, the blade is guided to the specified lane and either side to the continuation of the lane's cross-slope.

Lane guidance allows you to hold the machine guidance point onto a specified surface or lane. This is particularly useful when working on narrow surfaces such as a V ditch.

If you use the *3D, 1 Point Focus* guidance method and have *Adjust cut to avoid overcut* set to *Yes* any deviation of the focus tip across (or past) the center of the ditch will cause the blade to climb up the other side, altering the slope you are trying to build.

If you use the *3D, 1 Point Center* guidance method, any deviation of the center of the blade across (or past) the top of the ditch will cause the blade to flip to the next grade beside the ditch.

Both of these problems are solved by using Lane Guidance and holding the machine guidance point to the surface of the V ditch.

Lane Guidance can also be used to extend the grade of the lane either side (up to 1,000 meters) so that a continuous surface can be built at one grade. This is useful when building up large fills to reach the final design height. It also facilitates operations during the early stages of road construction by allowing the operator to build primary lanes(s) without being directly over them.

Lane guidance is perpendicular from the master alignment, as shown in [Figure 10.28](#). The master alignment runs up and down the screen. When you select a point for lane guidance, the plan lines to the immediate left and right of the point are found and are used to bound the lane. When either of the plan lines or the master alignment ends in the up or down direction, the lane also ends. Guidance based on lane selection will also end if there is no TIN under the lane bounding lines or if the lane turns more than 90 degrees away from the master alignment. The minimum lane width is 0.3 meters (12 inches).

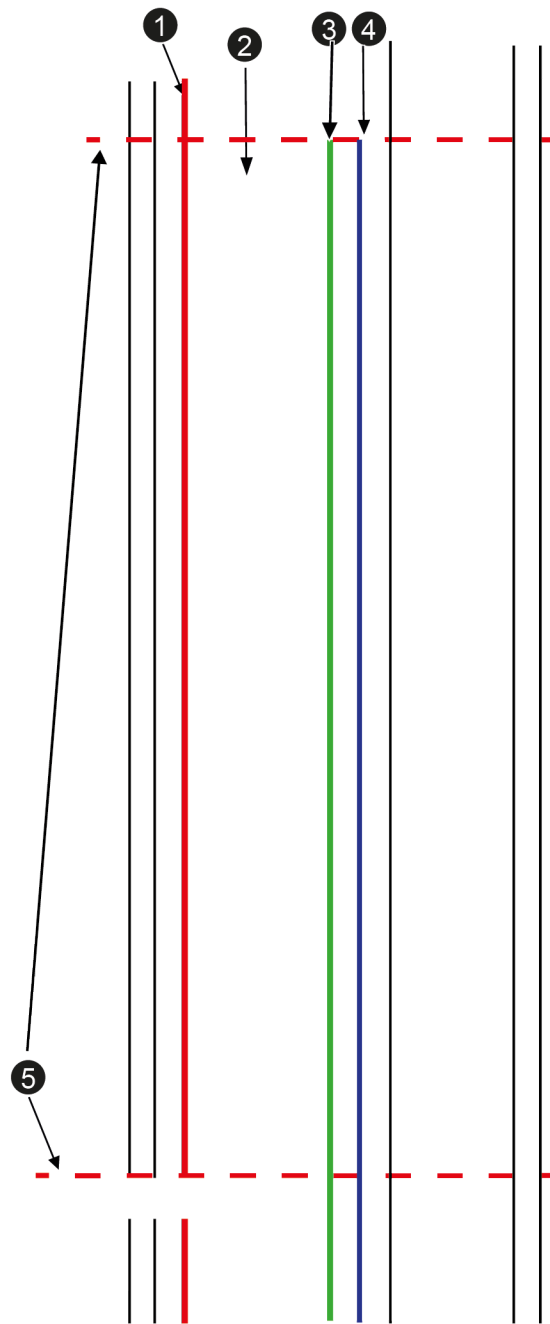

- 1** Red (left) lane side
- 2** Selected lane
- 3** Green (right) lane side
- 4** Master alignment
- 5** Lane end

Figure 10.28 Lane guidance bounds

Lane guidance can be used with the normal horizontal and vertical offsets and working surfaces. The normal vertical guidance points (3D 1 point center, 3D 2 points tips etc) are used to calculate the blade position on the lane.

### 10.5.1 Lane guidance indicator

In the figure below, the lane guidance indicator shows exactly where lane guidance is derived from. It consists of a line drawn across the lane (④), with lane focus points (⑤) defining the lane sides (① and ②). There is a lane guidance indicator for each vertical guidance point. The lane guidance indicator provides a projection of the slope, which is extended beyond the lane sides, through the lane focus points on either side of the lane. The lane guidance indicator moves with the machine.

The left blade tip for lane guidance is calculated using the lane guidance indicator. The height/slope of the right guidance tip (⑥) is interpolated from the cross-section of the lane focus points (⑤) which are perpendicular to the master alignment (③) and cross through the right guidance tip (⑥).

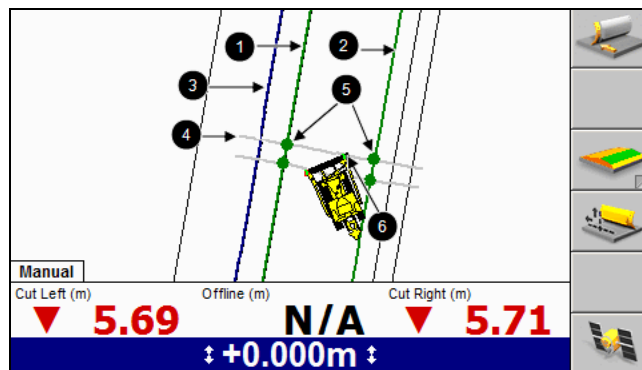

- ① Left lane side
- ② Right lane side
- ③ Master alignment
- ④ Lane guidance indicator line
- ⑤ Lane focus points
- ⑥ Right guidance tip

Figure 10.29 Lane guidance indicator with 2 points tips guidance

### 10.5.2 Extended lane guidance

The selected lane guidance is extended either side of the lane so that you can deliberately or temporarily get extended guidance, as shown in the figure below.

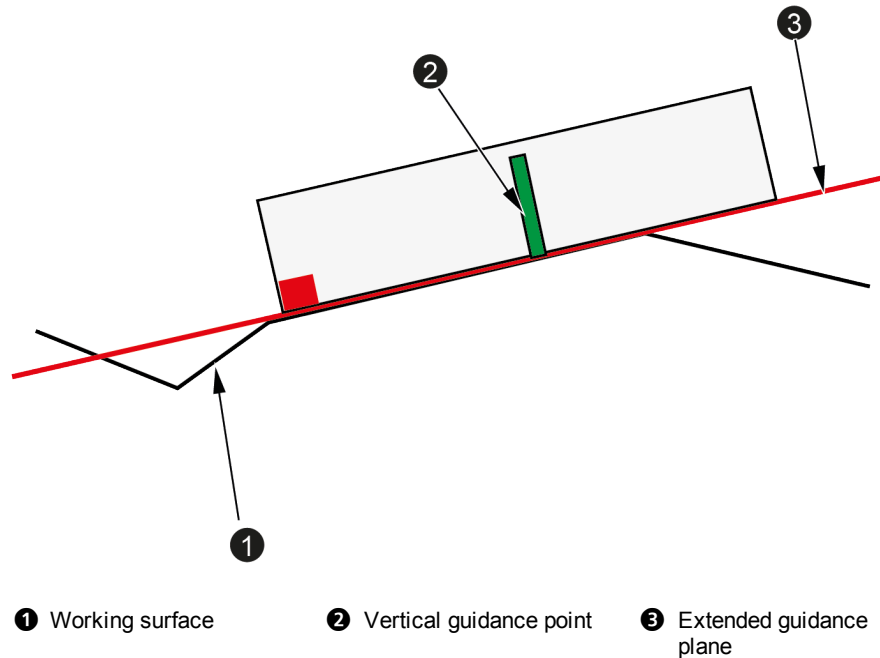

Figure 10.30 Extended lane guidance

The deliberate use of extended guidance allows you to create cut/fill layers, much like a Layered Lift does. This can also be offset in height so that the road can be built up or cut down in layers.

The temporary use of extended guidance can be used, for example, to cast excess material over the centerline of a road. While the north lane is selected and being built, excess material can be cast over onto the south lane. By doing this, the cutting edge can remain fixed to the cross-slope of the north lane at all times.

### 10.5.3 Master alignment

A master alignment is required for lane guidance. Often a master alignment is included in the design SVL/SVD from the office. If this is the case, the master alignment cannot be changed.



**Tip** – A master alignment can be included in an SVD/SVL design by using Trimble Business Center - HCE software in the office.

If a master alignment has not been included in the design SVD/SVL from the office, you will need to select a master alignment when you first select lane guidance. The master alignment should be parallel to the selected lane.

*Note – A master alignment can also be one of the two lane sides, perfectly fitting the expectation that the master alignment is parallel to the selected lane.*

The master alignment will be stored with the design and it will always be associated with it unless you select a different master alignment.

When it comes to more complex road designs that include such things as a clover leaf ramp, the position of the master alignment may need to change. In [Figure 10.31](#) below, the position of the master alignment in the clover leaf ramp is different from the master alignment on the main road.

---

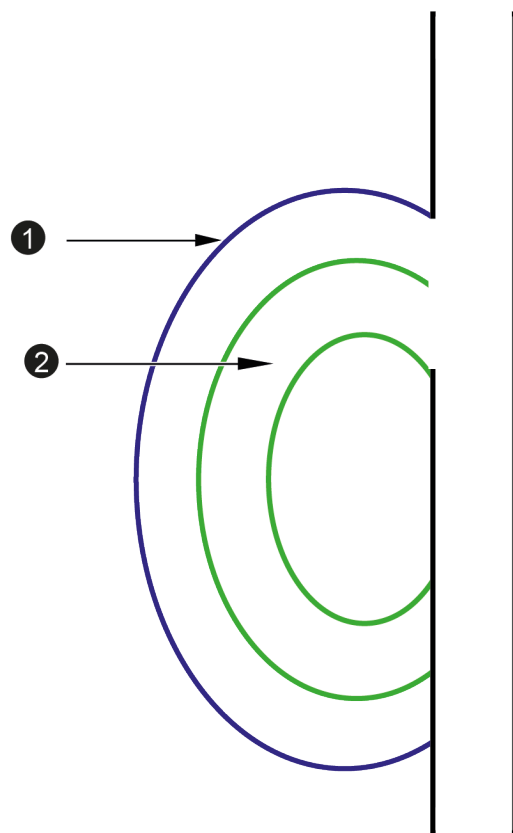

① Master alignment      ② Selected lane

---

Figure 10.31 Clover leaf ramp

When working with these type of designs where it is necessary for the master alignment to change positions, one of the following options can be chosen:

#### Master alignment from the office (included in design)

- Two different designs with two different master alignments need to be created, one for the main road and one for the clover leaf ramp.
- One design with one master alignment for the main road is created. When you start working on the clover leaf ramp, lane guidance should be turned off and conventional guidance methods used.

#### Master alignment selected by the user

- Select a master alignment for the main road. When you start working on the clover leaf ramp, change the master alignment accordingly.
- Select a master alignment for the main road. When you start working on the clover leaf ramp, lane guidance should be turned off and conventional guidance methods used.

*Note – A different master alignment could give different vertical guidance to the same section of the design. It is recommended that the same master alignment be used with the same lane.*



**Tip** – All master alignments are drawn as double-thick blue lines in plan view, whether lane guidance is turned on or off. This includes master alignments included in any design type from the office (SVD/SVL designs) and user defined master alignments.



**Tip** – Station / Chainage and MA Offset are useful text items and can be used with designs that include a master alignment.



**Tip** – The Station / Chainage text item only displays a value for a master alignment from the office.

## 10.6 3D guidance sensors

Any 3D sensor combination can support all the 3D guidance methods described in [10.7 3D guidance methods](#).

The following table lists the minimum sensor combinations required for 3D guidance:

Sensors	Comments
Single GNSS	Assumes that the blade is horizontal and not rotated

Sensors	Comments
Single GNSS plus:	
<ul style="list-style-type: none"> <li>• cross slope sensor group for motor graders and dozers</li> <li>• blade slope sensor for dozers</li> </ul>	Assumes dozer blades are not rotated
Single UTS	Assumes that the blade is horizontal and not rotated
Single UTS plus:	
<ul style="list-style-type: none"> <li>• cross slope sensor group for motor graders and dozers</li> <li>• blade slope sensor for dozers</li> </ul>	Assumes dozer blades are not rotated
Dual GNSS	—

The following figure shows a motor grader with a UTS and a cross slope sensor group installed.

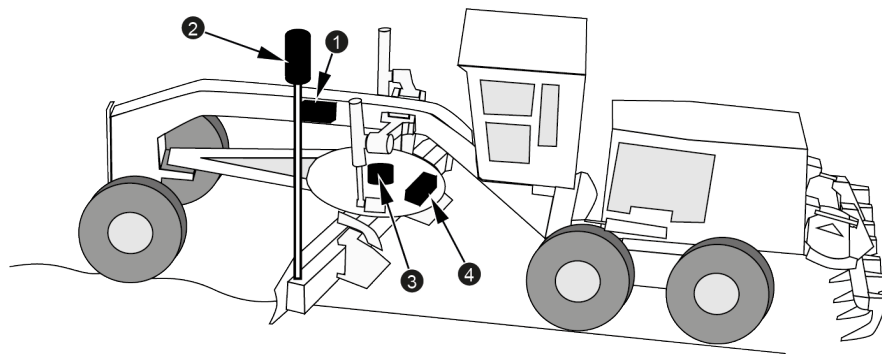

- ❶ AS400 mainfall sensor      ❷ MT900 UTS target      ❸ RS400 rotation sensor  
 ❹ AS400 blade slope sensor

Figure 10.32 A typical 3D system

## 10.7 3D guidance methods

Depending on the sensors installed on the machine, the system supports the following 3D guidance methods:

- One-point center 3D
- One-point focus 3D



- Two-points tips 3D

When using any 3D guidance method, the lightbars give guidance to both blade tips. The horizontal lightbar indicates horizontal corrections, if a horizontal alignment is selected.

The following figure shows an example of the relationship between the vertical lightbar patterns and the cross-section view guidance screen.

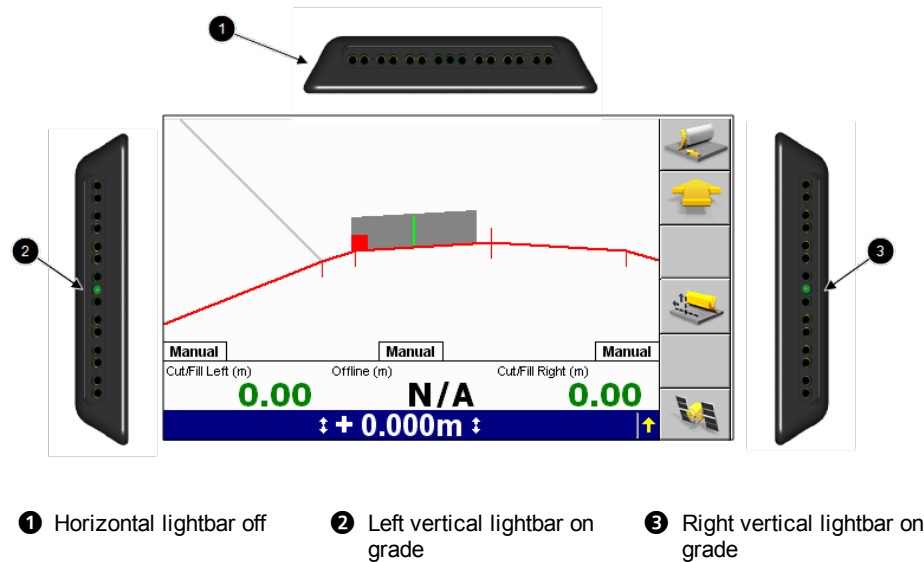

Figure 10.33 One-point center 3D guidance lightbar information

In addition to the lightbars, the optional text items *Cut/Fill Left* and *Cut/Fill Right* will also report vertical guidance corrections.

To learn how to set up and use 3D guidance methods, refer to the Operator's Manual for your machine.

### 10.7.1 One-point center 3D guidance

The one-point center 3D guidance method generates guidance information using a guidance plane based on a single vertical guidance point in the center of the blade.

The one-point center 3D guidance method is best suited to design surfaces made up of broad planes, including road designs.

#### One-point center 3D vertical guidance points

The following figure shows how the guidance plane is calculated for a vertical guidance point located at the mid-point of the cutting edge.

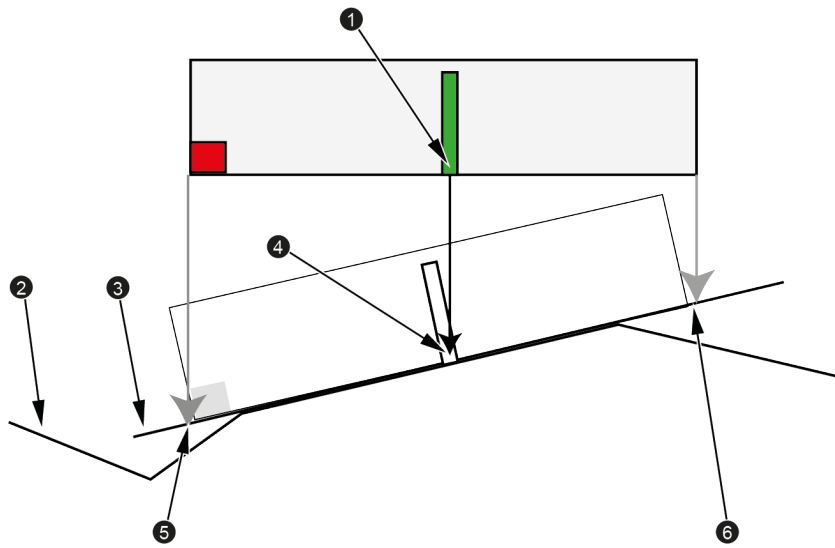

- ① Vertical guidance point
- ② Working surface
- ③ Guidance plane
- ④ Cross slope of guidance plane calculated at this point
- ⑤ Left tip correction (cut)
- ⑥ Right tip correction (cut)

Figure 10.34 Vertical guidance point for one-point center 3D guidance

### One-point center 3D guidance views

The following figure shows the cross-section view guidance screen when the system is gathering one-point center 3D data. The guidance screen displays a cross section of the job, at right angles to the direction of travel of the machine and the blade from the point of view of the operator.

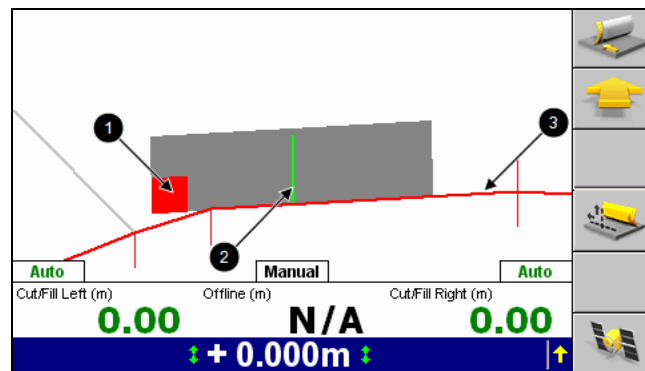

- ❶ Focus indicator
- ❷ Vertical guidance point indicator
- ❸ Working surface

Figure 10.35 A one-point center 3D cross-section view guidance screen

Points to note in Figure 10.35:

- The vertical guidance point indicator on the blade graphic indicates that a single, central, vertical guidance point is used to calculate the guidance plane.
- The left end of the blade is on grade even though it is above the working surface.

The following figure shows the plan view guidance screen when the system is gathering one-point center 3D data. The guidance screen displays a plan view of the site plan and a road design (.dc file).

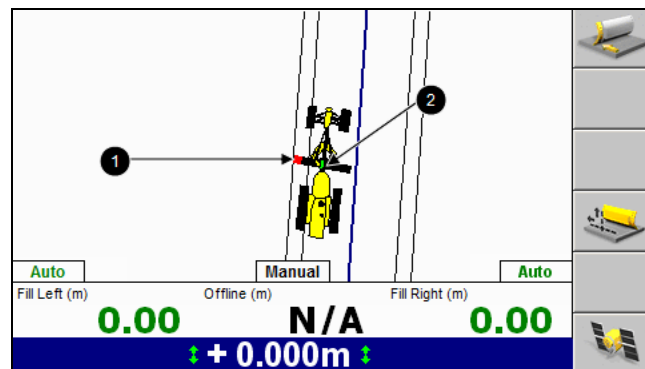

- ❶ Focus indicator
- ❷ Vertical guidance point indicator

Figure 10.36 A one-point center 3D plan view guidance screen

In addition to the plan and cross-section view guidance screens, there are also two optional text guidance screens available when you are using one-point center

guidance. The profile view guidance screen is also available for any design type, other than a road (.dc) design.

### 10.7.2 One-point focus 3D guidance

The one-point focus 3D guidance method uses a guidance plane based on a single vertical guidance point at the tip of the blade receiving horizontal guidance to generate guidance information.

The one-point focus 3D guidance method is best suited to working design surface features that are less than half a blade width wide, or design surfaces with small features that need to be formed.

#### One-point focus 3D vertical guidance points

The following figure shows how the guidance plane is calculated for a vertical guidance point located at the focus of the cutting edge.

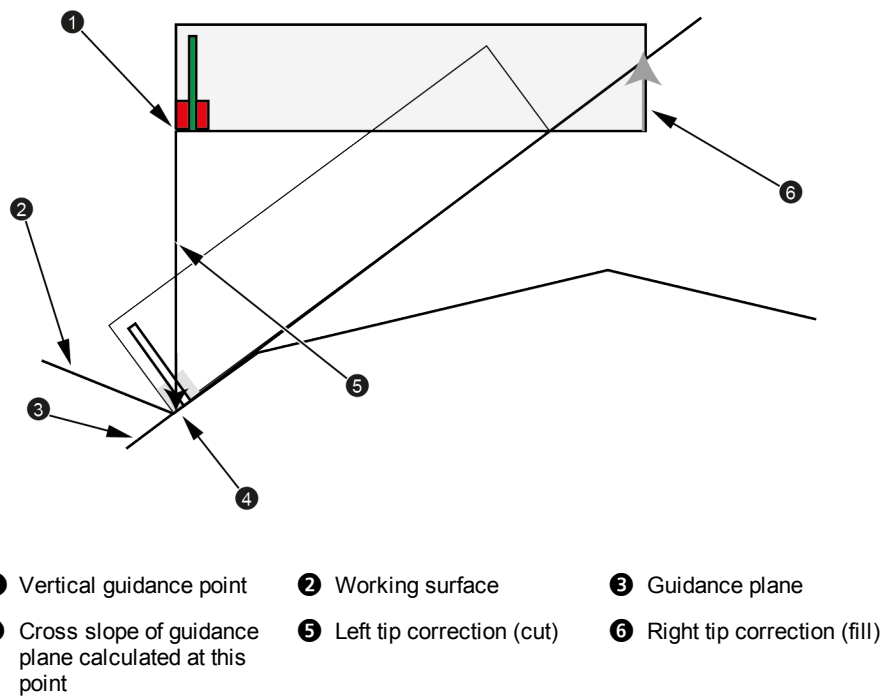
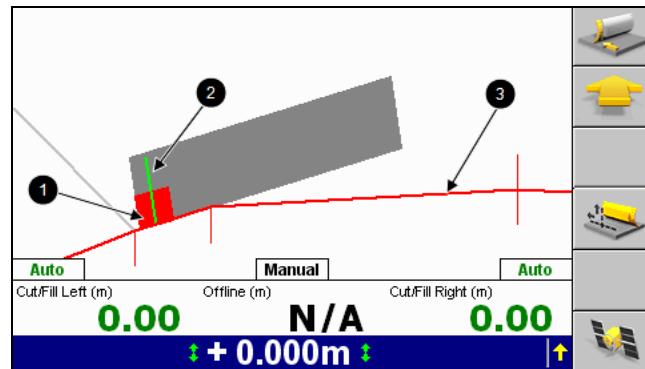

Figure 10.37 Vertical guidance point for one-point focus 3D guidance

### One-point focus 3D guidance views

The following figure shows the cross-section view guidance screen when the system is gathering one-point focus 3D data. The guidance screen displays a cross section of the job and the blade, at right angles to the direction of travel of the machine, from the point of view of the operator.



- ❶ Focus indicator
- ❷ Vertical guidance point indicator
- ❸ Working surface

Figure 10.38 A one-point focus 3D cross-section view guidance screen

Points to note in [Figure 10.38](#):

- The guidance plane is being calculated using a single vertical guidance point located at the tip of the cutting edge that has focus, as indicated by the vertical guidance point indicator on the blade graphic.
- The right end of the blade is on grade, even though it is above the working surface.

The plan view guidance screen is similar to that of [One-point center 3D guidance](#).

In addition to the plan and cross-section view guidance screens, there are also two optional text guidance screens available when you are using one-point focus guidance. The profile view guidance screen is also available for any design type, other than a road (.dc) design.

### One-point focus 3D vertical guidance points

The following figure shows how the guidance plane is calculated for a vertical guidance point located at the focus of the cutting edge.

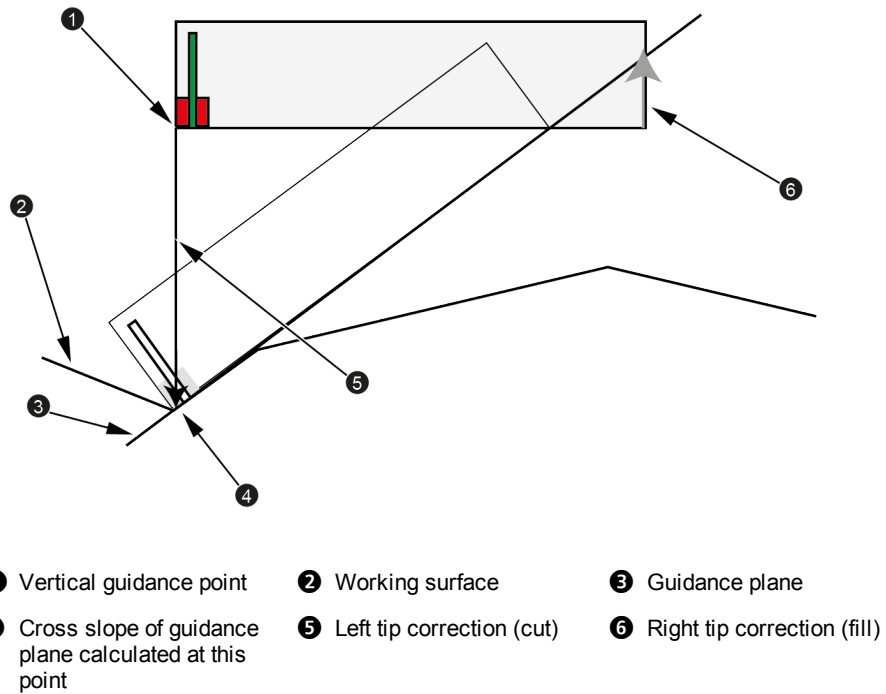
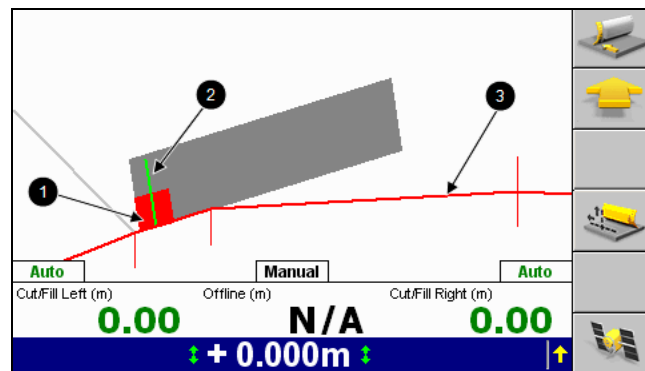

Figure 10.39 Vertical guidance point for one-point focus 3D guidance

### One-point focus 3D guidance views

The following figure shows the cross-section view guidance screen when the system is gathering one-point focus 3D data. The guidance screen displays a cross section of the job and the blade, at right angles to the direction of travel of the machine, from the point of view of the operator.



- ❶ Focus indicator
- ❷ Vertical guidance point indicator
- ❸ Working surface

Figure 10.40 A one-point focus 3D cross-section view guidance screen

Points to note in [Figure 10.40](#):

- The guidance plane is being calculated using a single vertical guidance point located at the tip of the cutting edge that has focus, as indicated by the vertical guidance point indicator on the blade graphic.
- The right end of the blade is on grade, even though it is above the working surface.

The plan view guidance screen is similar to that of [One-point center 3D guidance](#)

In addition to the plan and cross-section view guidance screens, there are also two optional text guidance screens available when you are using one-point focus guidance. The profile view guidance screen is also available for any design type, other than a road (.dc) design.

### 10.7.3 Two-points tips 3D guidance

The two-points tips 3D guidance method generates guidance information using a guidance plane based on two vertical guidance points near the tips of the blade.

The two-points tips 3D guidance method tends to have an “averaging” effect on design surfaces, and is best suited to working complicated design surfaces where a smooth finish is desired.

#### Two-point tips 3D vertical guidance points

The following figure shows how the guidance plane is calculated for two vertical guidance points inset from the tips of the cutting edge.

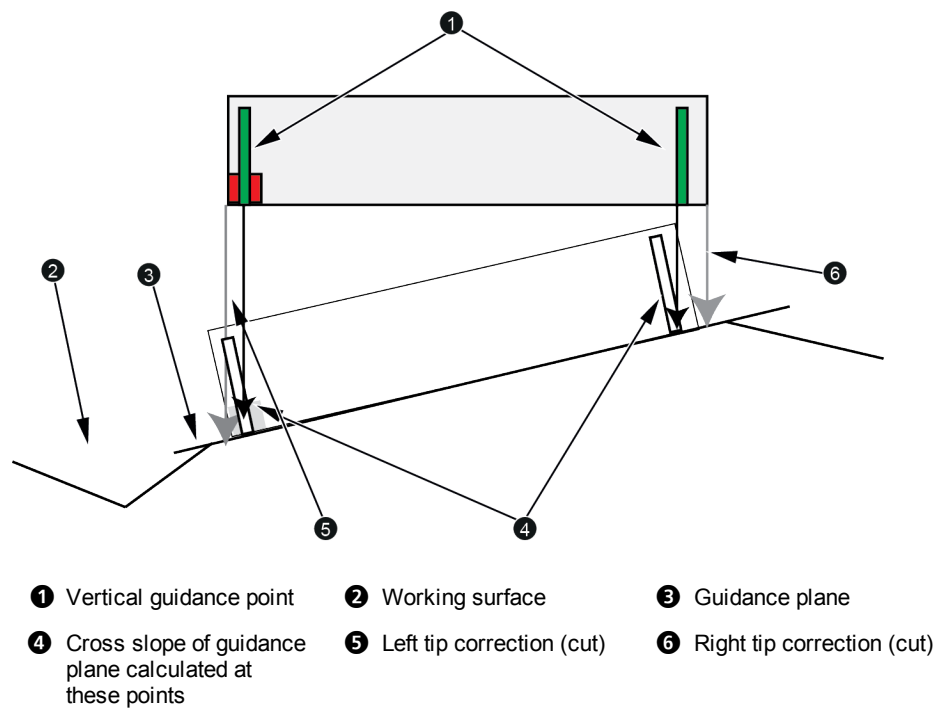

Figure 10.41 Vertical guidance point for two-point tips 3D guidance

By default each vertical guidance point is inset by 200 mm from the tip of the cutting edge.

### Two-points tips 3D guidance views

The following figure shows the cross-section view guidance screen when the system is gathering two-points tips 3D data. The guidance screen displays a cross section of the job, at right angles to the direction of travel of the machine, and the blade, from the point of view of the operator.



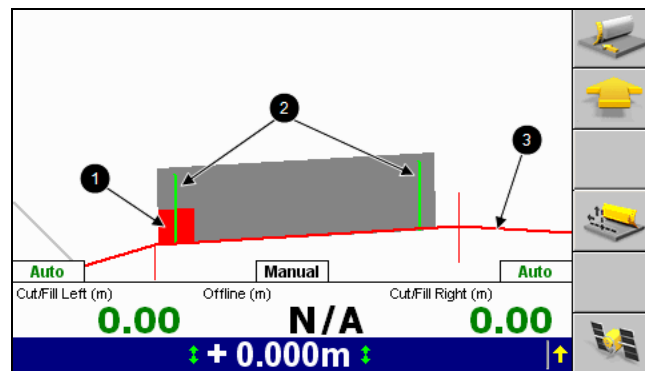

- ❶ Focus indicator                      ❷ Vertical guidance point indicators

Figure 10.42 A two-points tips 3D cross-section view guidance screen

The plan view guidance screen is similar to that of [One-point center 3D guidance](#).

In addition to the plan and cross-section view guidance screens, there are also two optional text guidance screens available when you use two-points tips guidance. The profile view guidance screen is also available for any design type, other than a road (.dc) design.

## 10.8 Switching between conventional and 3D guidance systems

The operator can use a 2D guidance method on a 3D-configured system even if the sensors required for the 3D configuration are not detected. Furthermore, you can easily switch between 3D and 2D guidance methods as an alternative to using multiple machine settings files. This feature is available on 3D excavators and all grading systems.

To learn how to swap between systems, refer to the *GCS900 Grade Control System Operator's Manual* for your machine type.

## 10.9 Cut adjustment

In some situations the guidance information generated by one-point guidance methods, or two-point guidance methods where the vertical guidance points are located well in from the tips, will cause the tips of the blade to cut into the design surface. This is called overcut. The system gives you the option of automatically adjusting cut/fill guidance to prevent overcut.

**Note** – *Overcut protection has no effect when you use the default two-points tips guidance method. For example, if the blade straddles the crown of a road, the crown may be cut off.*

The lightbars and the *Cut/Fill* text items provide blade tip guidance to the adjusted vertical guidance plane. The *Cut Adjust* text item can be selected to display the adjustment that has been made to avoid overcut.

The following illustrations highlight some situations where overcut protection will have a significant impact on the blade guidance. The illustrations on the left show outcomes with overcut protection *off*. The illustrations on the right show outcomes with overcut protection *on*.

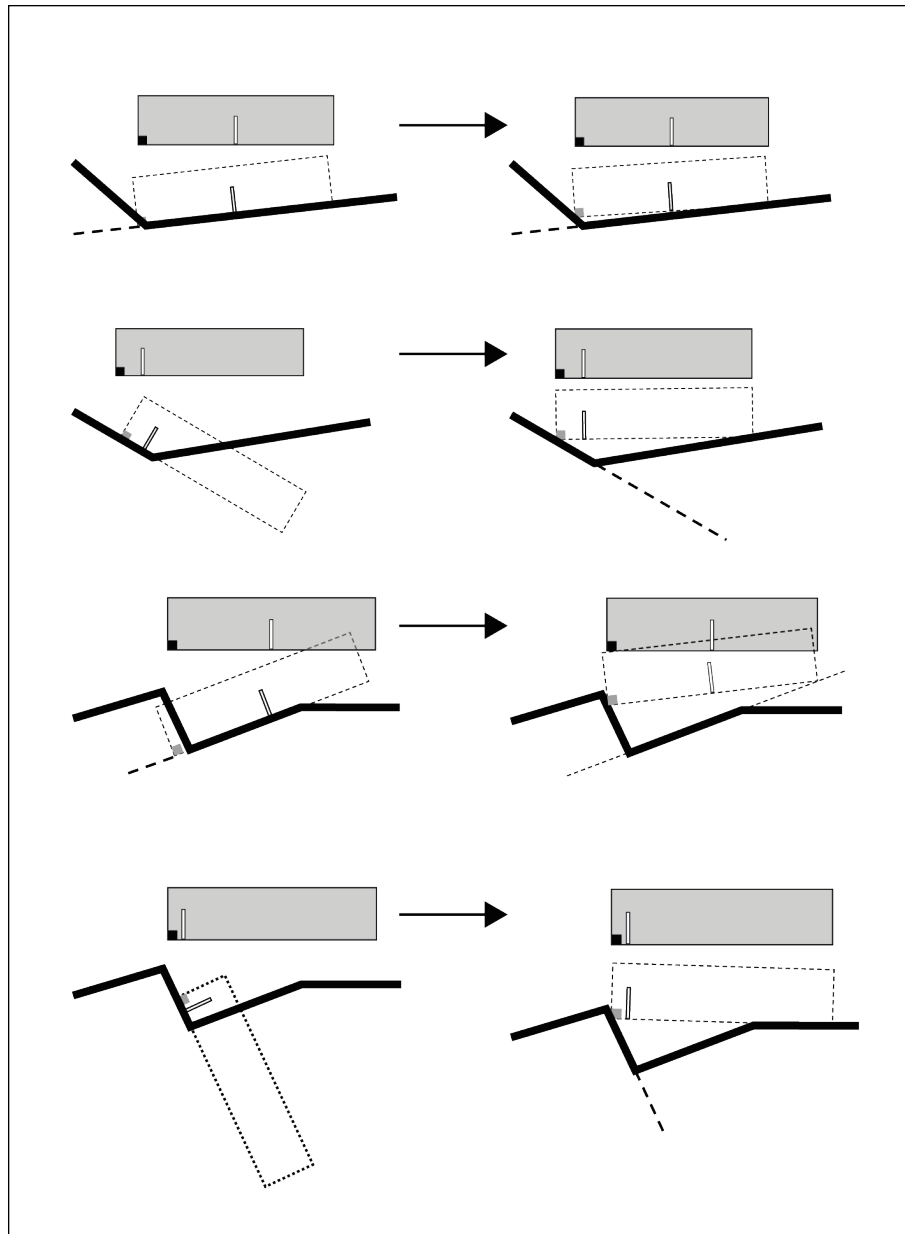

## 10.10 Horizontal guidance

The system generates horizontal guidance information relative to the following design features:

- Design alignments in road files, including widening and superelevation
- 3D lines
- Master alignment of sloping surfaces
- Design boundaries and linework in site maps and background plans
- Dynamic layered lifts

These design features are called horizontal alignments, or simply, alignments.

To generate horizontal guidance corrections, the system calculates the horizontal distance between the focus point on the cutting edge of the blade and the selected horizontal alignment.

When you select a horizontal alignment, the horizontal lightbar indicates horizontal corrections.

The following figure shows an example of the relationship between the horizontal lightbar pattern and the cross-section view guidance screen.

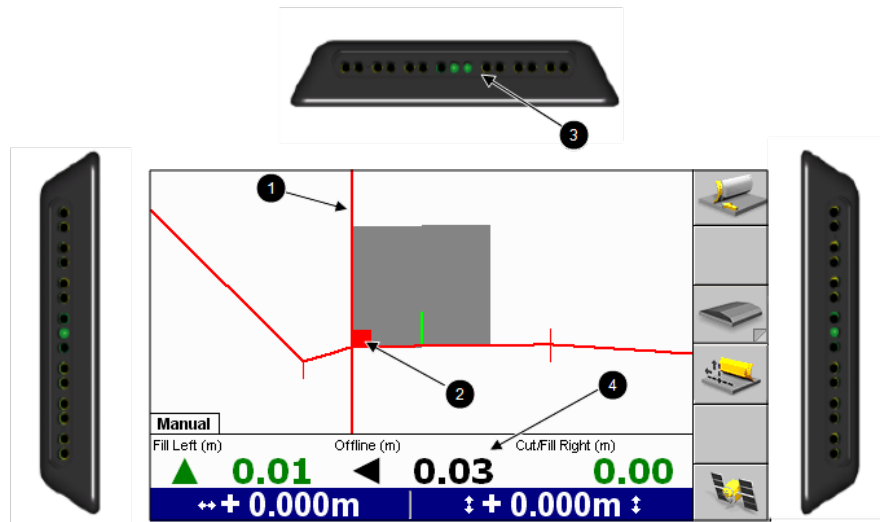

- ❶ Horizontal alignment
- ❷ Focus - horizontal guidance point
- ❸ Horizontal lightbar between 25 mm and 50 mm to the right
- ❹ "Offline" - the 3D horizontal guidance text item

Figure 10.43 An example of horizontal guidance (external lightbars)

*Note* – If no horizontal alignment is selected the horizontal lightbar is turned off.

In addition to the lightbars, the optional text item *Offline* will also report horizontal guidance corrections.

### 10.10.1 Road design alignments

Each alignment in an .svd or .dc road design file is numbered, and can also be named. The master alignment is *always* alignment number “0”. Positive alignment numbers are alignments to the true right of the master alignment. Negative alignment numbers are alignments to the true left of the master alignment.



**Tip** – “True right” and “true left” mean right and left in the direction of the road looking away from the starting point or first station in the design. If the machine is facing back toward the start of the road, positive alignments appear to the left of the master alignment.

If the alignment selected for horizontal guidance stops, or is no longer available at your current position:

- the LEDs at each end of the horizontal lightbar flash repeatedly
- the text items for horizontal guidance appear as **N/A**

However, the system remembers the alignment, and horizontal guidance resumes when the selected alignment reappears.

In the cross-section view guidance screen, the selected alignment is drawn with a vertical red line. If a horizontal offset is applied, the selected alignment is drawn with a double-width black tick mark, and the working alignment is drawn with a vertical red line.

The following figure shows a cross-section view guidance screen when an alignment is selected for horizontal guidance.

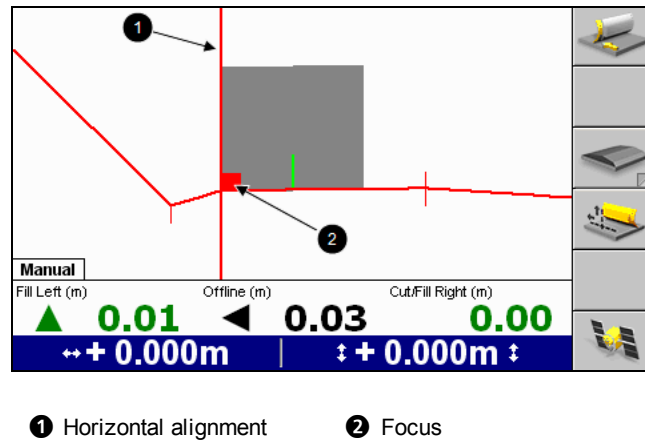
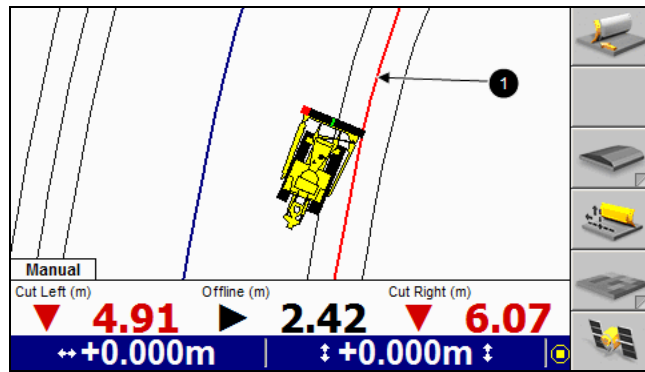

Figure 10.44 A cross-section view of horizontal guidance to a road alignment

In the plan view guidance screen, the selected alignment is drawn with a double-width red line. If a horizontal offset is applied, the selected alignment is drawn with a double-width black line, and the working alignment is drawn with a double-width red line.

The following figure shows a plan view guidance screen when an alignment is selected for horizontal guidance. Notice the additional road alignments.



1 Horizontal alignment

Figure 10.45 Plan view of a road design with an alignment selected for horizontal guidance

*Note* – The cross-section view also displays any graphical lines selected for horizontal guidance.

The following table explains the items in [Figure 10.44](#) and [Figure 10.45](#):

Item	Description
Horizontal offset	Horizontal offset is the offset distance left (–) or right (+) of the selected alignment.
Design surface	The surface, defined in the design, that guidance is provided to.
Working alignment	Shown as a vertical red line above and below the working surface. It is parallel to the selected alignment, and offset by the horizontal offset value. Keep the guidance point that has focus on this line.
Master alignment	The major alignment of a road or slope design.

A road design file can be exported from Business Center – HCE or SiteVision Office version 5.5, or later, software as an .svd file with an accompanying .svl roading linework file. If a road file is exported in this way, you can enable auto selection of the horizontal alignment.

When the Autoselect option is active, the system selects the alignment that is closest to the blade tip that has focus as the horizontal guidance reference. As you work along the alignment, the system finds all alignments that have the same name as the selected alignment.

When the roading alignment stops, the Autoselect feature searches for the start of the next alignment within a radius of 2 m (6 ft) from the blade tip that has focus. Continue in the required direction until the next alignment is selected.



**Tip** – If you use Autoselect, you do not have to reselect the same alignment when the line is not continuous.

Road alignments are only available in .svl files when the .dc file is exported from Business Center – HCE or SiteVision Office as a combination of .svl and .svd files.

### 10.10.2 Road design layered lift alignments

The intersection of a layered lift working surface and the original road design (.dc) surface can be selected for horizontal guidance.

In the cross-section view guidance screen, the selected alignment is drawn with a vertical red line. If a horizontal offset is applied, the selected alignment is drawn with a double-width black tick mark, and the working alignment is drawn with a vertical red line.

The following figure shows a cross-section view guidance screen when the true-left layered lift alignment is selected for horizontal guidance.

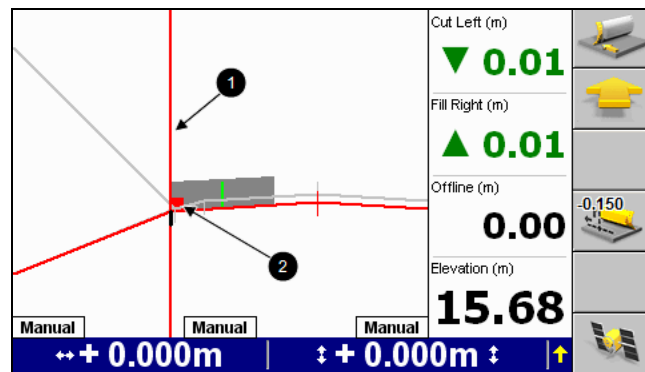

- ① Horizontal alignment      ② Focus

Figure 10.46 Cross-section view of a road design with a layered lift alignment selected

In the plan view guidance screen, the selected alignment is drawn with a double-width red line. If a horizontal offset is applied, the selected alignment is drawn with a double-width black line, and the working alignment is drawn with a double-width red line. The plan view guidance screen is similar to [Figure 10.45](#).

### 10.10.3 Horizontal guidance to a dynamic layered lift alignment

Horizontal guidance is given to single slope and dual slope dynamic layered lift designs in the same way as with any other design. For more information see [Layered lifts, page 162](#).

In addition, for .dc designs, the intersection of the dynamic layered lift working surface and the original road design surface (known as the daylight points) can be selected for horizontal guidance.

By default, daylight point markers appear in the plan view guidance screen for single slope and dual slope dynamic layered lift designs. The markers are drawn as short bold black lines.

The daylight point markers move as the machine moves to show the daylight points for the current blade height.

When a daylight point is selected for horizontal guidance, the daylight point marker appears as a short bold red line, and the *Offline DL* and *Offline DR* text items shows the distance from the blade tip with focus to the selected daylight point, as shown in the following figure.

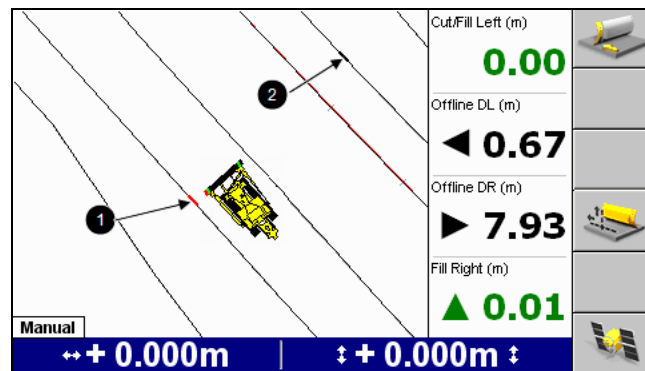

- ❶ Left daylight point selected for horizontal guidance      ❷ Right daylight point

Figure 10.47 Plan view guidance screen with daylight point markers

Daylight points do not appear in the cross-section view guidance screen.

### Horizontal position information

There are optional text items that provide information about the machine's position relative to two alignments. This horizontal guidance information is given to the daylight points via the following text items:

- Offline L
- Offline R
- Offline DL
- Offline DR

The calculation of each horizontal guidance text item considers the vertical guidance point or points. The vertical guidance point, or mid-point between two vertical guidance points is used as the dividing point to separate the alignments into two groups.



Alignments on the left of this dividing point are considered for *Offline L* and *Offline DL* guidance. Alignments on the right of this dividing point are considered for *Offline R* and *Offline DR* guidance.

The horizontal guidance text items are:

- *Offline L* (Left) and *Offline R* (Right):
  - The distance from each blade tip to the closest alignment to that blade tip.
  - DC (.dc) designs calculate the distance along a cross-section of the road that is at right angles to the master alignment and that passes through the vertical guidance point, or mid-point between the vertical guidance points, as shown in the following figure.

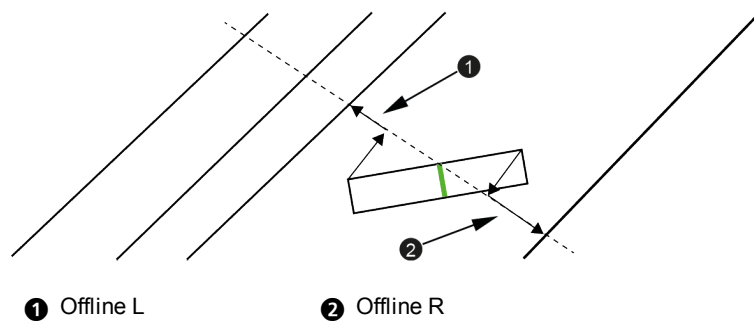

Figure 10.48 Offline L and Offline R for a DC (.dc) road design

- SV (.svd) designs calculate the distance along a line through the blade, and only consider named alignments, as shown in the following figure.

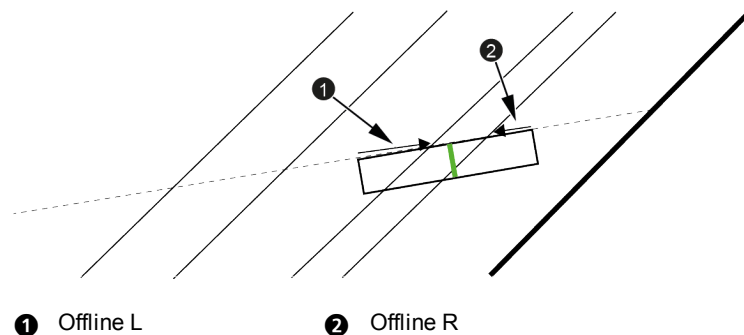

Figure 10.49 Offline L and Offline R for an SV (.svd) road design

- For design files other than SV and DC, N/A is shown.
- *Offline DL* (Dynamic Left) and *Offline DR* (Dynamic Right):
  - For single slope DC designs, the value is the distance from the respective blade tip to the closest daylight point, as shown in the following figure.

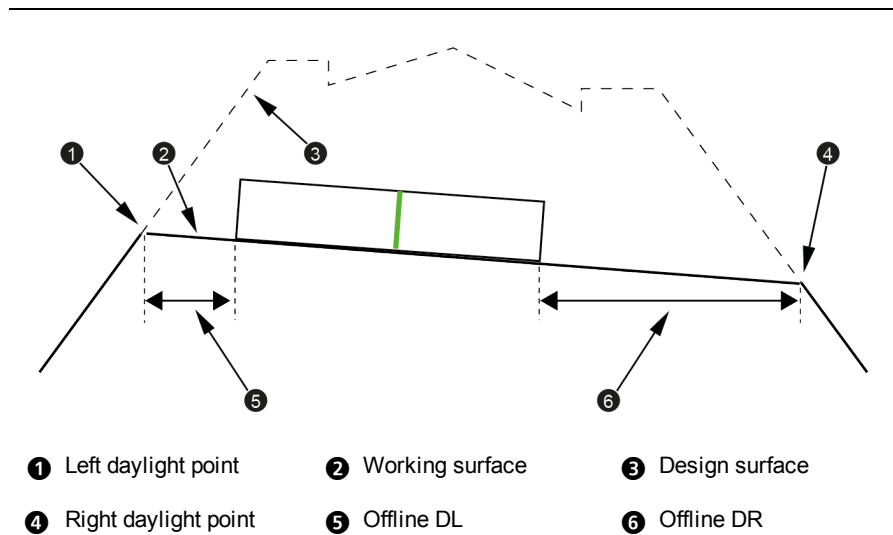

Figure 10.50 Offline DL and Offline DR calculated for a single slope DC design

- For dual slope DC designs, the center alignment is also considered, as shown in the following figure.

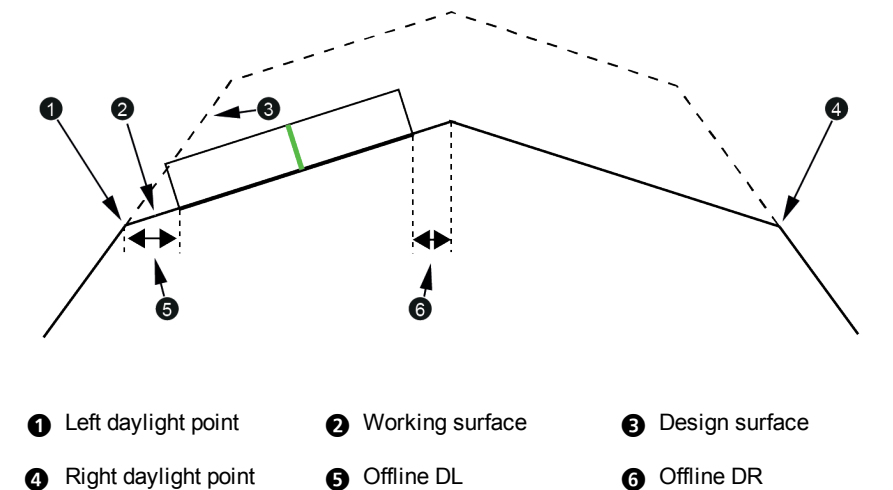

Figure 10.51 Offline DL and Offline DR calculated for a dual slope DC design

- For SV and standard (.dc) road designs, DL is the distance from the left tip of the blade to the left most alignment; DR is the distance from the right tip of the blade to the right most alignment, as shown in the following figure.

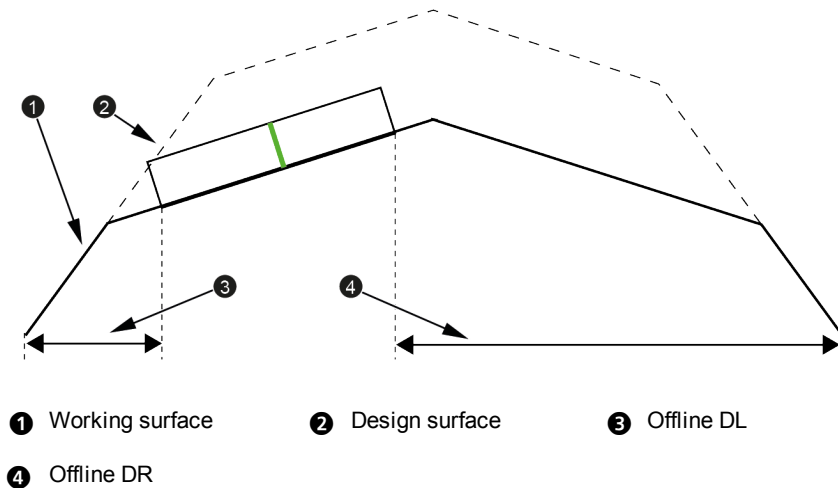

Figure 10.52 Offline DL and Offline DR calculated for SV and standard road designs

- For designs other than SV and DC, N/A is shown.

#### 10.10.4 Road design side slopes

If the selected road design includes side slopes, guidance can be given to the cut or the fill side slope.

#### 10.10.5 3D lines

Horizontal guidance to a 3D line is given by default when the 3D line is first selected for vertical guidance.

In the cross-section view guidance screen, the selected alignment is drawn with a vertical red line. If a horizontal offset is applied, the selected alignment is drawn with a double-width black tick mark, and the working alignment is drawn with a vertical red line.

The following figure shows a cross-section view guidance screen when a 3D line is selected for horizontal guidance.

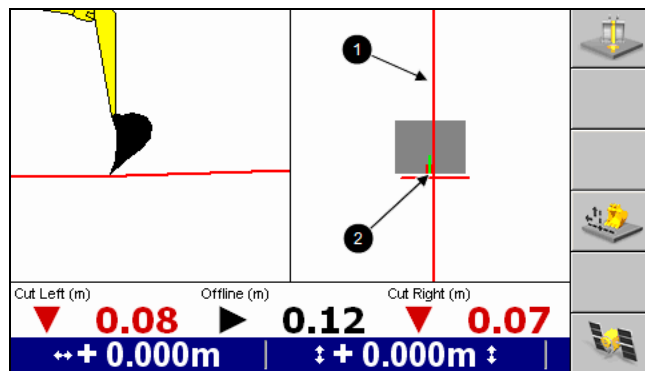

- ❶ Selected horizontal alignment
- ❷ Focus

Figure 10.53 Cross-section view of a 3D Lines design

In the plan view guidance screen, the selected alignment is drawn with a double-width red line. If a horizontal offset is applied, the selected alignment is drawn with a double-width red line, and the working alignment is drawn with a double-width blue line.

The following figure shows a plan view guidance screen when a 3D line alignment is selected for horizontal guidance.

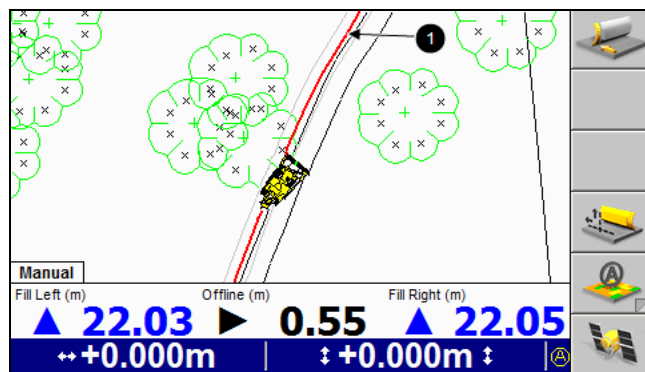

- ❶ Selected horizontal alignment

Figure 10.54 Plan view of a 3D Lines design

The direction of a 3D line is from the A end to the B end.

### 10.10.6 Sloping surface master alignment

The master alignment of a sloping surface can be selected as a horizontal guidance line. The master alignment is alignment number “0”.

In the cross-section view guidance screen, the selected alignment is drawn with a vertical red line. If a horizontal offset is applied, the selected alignment is drawn

with a double-width black tick mark, and the working alignment is drawn with a vertical red line.

The following figure shows a cross-section view guidance screen when the master alignment is selected for horizontal guidance.

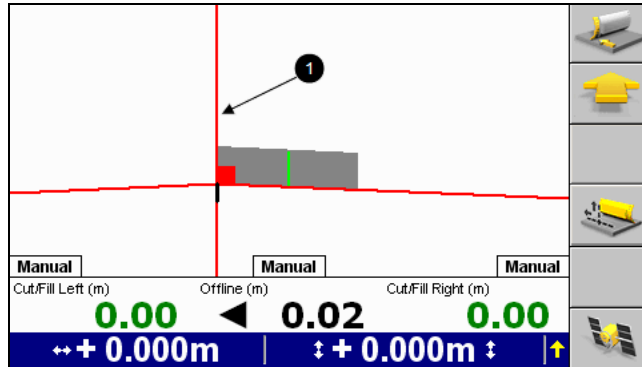

❶ Master alignment is selected for horizontal alignment

Figure 10.55 Cross-section view of a sloping surface design

In the plan view guidance screen, the selected alignment is drawn with a double-width red line. If a horizontal offset is applied, the selected alignment is drawn with a double-width black line, and the working alignment is drawn with a double-width red line.

The following figure shows a plan view guidance screen when the master alignment is selected for horizontal guidance.

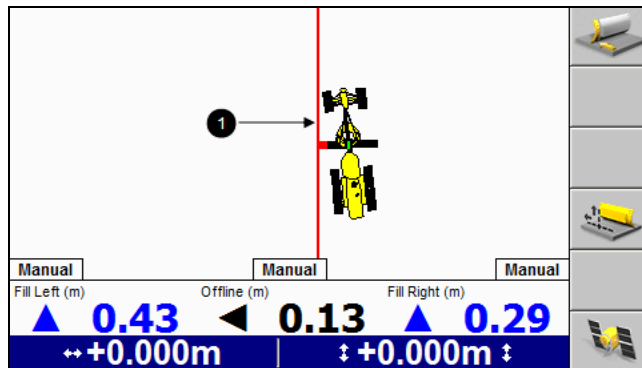

❶ Master alignment is selected for horizontal alignment

Figure 10.56 Plan view of a sloping surface design

For sloping surfaces defined by the Two Points method, the direction of the master alignment is from the first point toward the second master alignment point.

For sloping surfaces that are defined by the Point-and-Direction method, the direction of the master alignment is the direction specified.

### 10.10.7 Plan lines

You can select the following design features for horizontal guidance:

- Design boundaries
- Site map linework
- Background plan linework

Most designs have an associated boundary that can be graphically selected for horizontal guidance. A boundary indicates the extents of the vertical design data.

You can also select any line that appears in the site map or background plan for horizontal guidance.

**Note** – You cannot select design text or avoidance zone boundaries for horizontal guidance.

In the cross-section view guidance screen, the selected alignment is drawn with a vertical red line. If a horizontal offset is applied, the selected alignment is drawn with a double-width black tick mark, and the working alignment is drawn with a vertical red line.

The following figure shows a cross-section view guidance screen with an SV design loaded and a plan line, the design boundary, is selected for horizontal guidance.

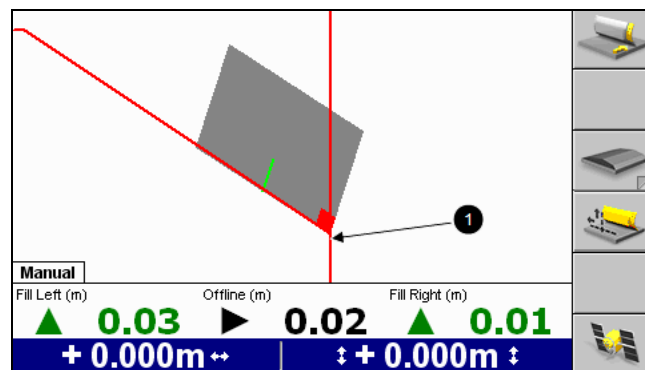

- ① Selected horizontal alignment

Figure 10.57 An SV design with a plan line selected for horizontal guidance

In the plan view guidance screen, the selected alignment is drawn with a double-width red line. If a horizontal offset is applied, the selected alignment is drawn with

a double-width black line, and the working alignment is drawn with a double-width red line.

The following figure shows a plan view guidance screen when a plan line, the design boundary, is selected for horizontal guidance.

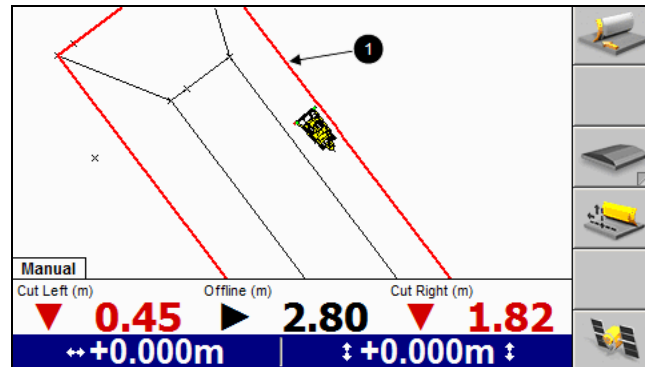

① Selected horizontal alignment

Figure 10.58 Plan view of an SV design with a plan line selected for horizontal guidance

### 10.10.8 Horizontal offsets

Setting a horizontal offset moves the horizontal guidance alignment away from the selected alignment. You add or subtract an offset square to the selected horizontal alignment.

*Note* – The horizontal offset limit is  $\pm 300$  m.

When you apply horizontal offsets, the direction of the alignment is forward, going up the graphical selection screen. The following exceptions to the direction of the alignment apply:

- Circles have negative horizontal offsets applied inward, and positive offsets applied outward.
- Closed shapes constructed of a series of line segments use the same convention as circles.
- Road alignments and sloping surface master alignments ignore the screen orientation. These use the direction of increasing station (chainage) values along the master alignment.
- 3D lines alignments ignore the screen orientation. These use the direction from end A to end B.

Typically, in the cross-section view guidance screen, when a horizontal offset is applied, the selected alignment is drawn with a double-width black tick mark, and the working alignment is drawn with a vertical red line.

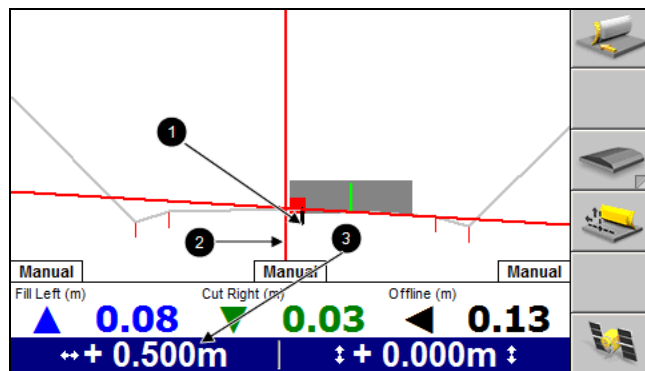

- ❶ Selected horizontal alignment
- ❷ Working horizontal alignment
- ❸ Value of horizontal offset

Figure 10.59 Cross-section view of a typical horizontal offset

Typically, in the plan view guidance screen, when a horizontal offset is applied, the selected alignment is drawn with a double-width black line, and the working alignment is drawn with a double-width red line.

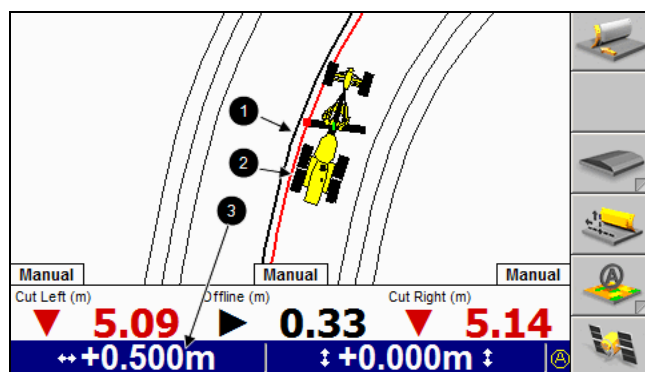

- ❶ Selected horizontal alignment
- ❷ Working horizontal alignment
- ❸ Value of horizontal offset

Figure 10.60 Plan view of a typical horizontal offset

For 3D lines designs, in the cross-section view guidance screen, when a horizontal offset is applied, the selected alignment is drawn with a double-width black tick mark, and the working alignment is drawn with a vertical red line.



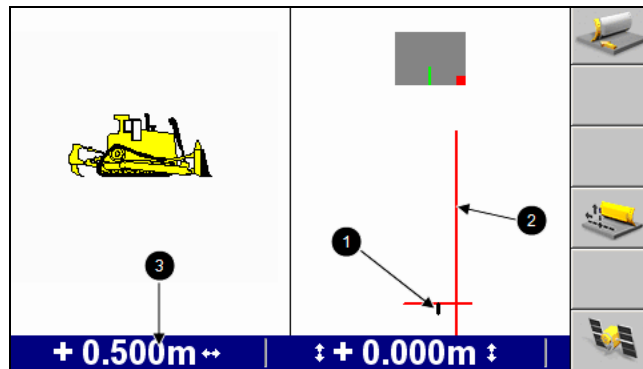

- ❶ Selected horizontal alignment
- ❷ Working horizontal alignment
- ❸ Value of horizontal offset

Figure 10.61 Split screen view of a 3D lines horizontal offset

For 3D lines designs, in the plan view guidance screen, when a horizontal offset is applied, the selected alignment is drawn with a double-width blue line, and the working alignment is drawn with a double-width red line.

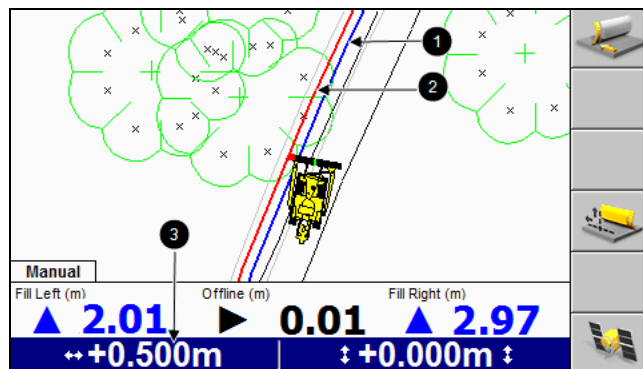

- ❶ Selected horizontal alignment
- ❷ Working horizontal alignment
- ❸ Value of horizontal offset

Figure 10.62 Plan view of a 3D lines horizontal offset

## 10.11 Machine orientation and pitch

If you power up the system with the machine in the same position as the machine was in when the system was last powered down, the system uses the last orientation and pitch information that it generated.

If you move the machine more than a short distance with the system turned off, the system discards the old orientation and pitch information, and new orientation and pitch data must be generated.

Some 3D systems need the machine to move before the system can estimate the direction the machine is moving (forward or backward) or the pitch of the machine:

- Single-GNSS and UTS systems need the machine to move in order to initialize the orientation of the machine.
  - The system displays the *Direction* dialog or the **Direction Unknown** flashing warning message.
- Dual-GNSS configurations that do not use a mainfall sensor or a blade pitch sensor need the machine to move in order to initialize the pitch of the machine.
  - The system displays the **Low Accuracy (Move)** flashing warning message.

For more information, refer to the *GCS900 Grade Control System Operator's Manual* for your machine type.

## Hybrid guidance systems

### In this chapter:

- Introduction
- Overview of hybrid guidance
- 3D plus sonic tracer guidance

This chapter describes the hybrid guidance system features of the GCS900 Grade Control System.

## 11.1 Introduction

Hybrid guidance systems combine the features of 3D systems, such as providing grade information relative to a digital design, with the features of conventional systems, such as providing grade information relative to an existing surface.

## 11.2 Overview of hybrid guidance

Some configurations of the GCS900 Grade Control System support the guidance of one blade tip using a 3D guidance method, while simultaneously guiding the opposite blade tip using a conventional method. These systems are referred to as hybrid guidance systems.

Hybrid guidance systems enable you to guide the elevation of one blade tip using a digital design, while guiding the opposite blade using an existing surface, such as a curb.

Hybrid guidance systems can also provide horizontal guidance.

GCS900 Grade Control System supports the following hybrid guidance systems:

- [3D plus sonic tracer guidance](#)

For more information on conventional and 3D systems, see [Chapter 8, Conventional Guidance Systems](#) and [Chapter 10, 3D Guidance Systems](#).

## 11.3 3D plus sonic tracer guidance

3D plus sonic tracer guidance is a combination of 3D guidance, used to determine the height of one blade tip, and conventional lift guidance, provided by a sonic tracer, for the opposite blade tip.

3D plus sonic tracer guidance enables you to simultaneously:

- Set and maintain the height of one tip of the cutting edge relative to a reference elevation using the sonic tracer.
- Control the height of the other tip of the cutting edge, to match the 3D design elevation at the current blade location, independent of the mainfall and cross slope of the machine and the rotation of the blade.

3D plus sonic tracer is useful for grading to a 3D design while matching the elevation of an existing reference surface, such as a kerb. For machines with automatic controls, you can control the height of both blade tips in the following way:

- The automatic controls adjust the height of one blade tip to maintain a preset elevation relative to a reference surface.
- The automatic controls adjust the height of the other blade tip to maintain the 3D design elevation.

### 11.3.1 3D plus sonic tracer sensors

The minimum sensor combinations for 3D plus sonic tracer guidance are:

- Sonic tracer, blade slope, single 3D (blade square)
- Sonic tracer, cross slope sensor group, single 3D
- Sonic tracer, dual GNSS
- Sonic tracer, single UTS

The following figure shows a motor grader with the cross slope sensor group (mainfall, blade slope and blade rotation sensors), a sonic tracer, and a UTS sensor providing conventional lift control of the left blade tip and 3D elevation control of the right blade tip:

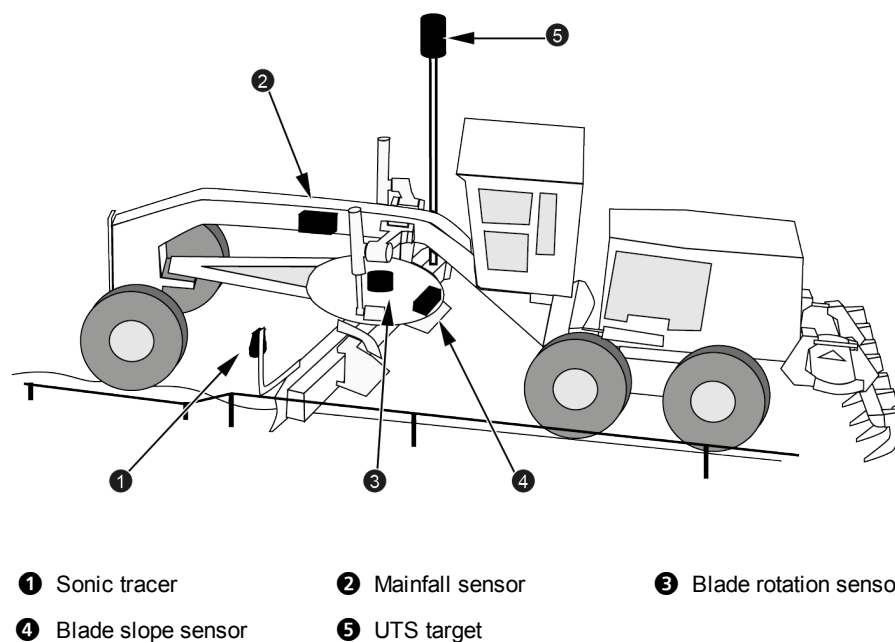
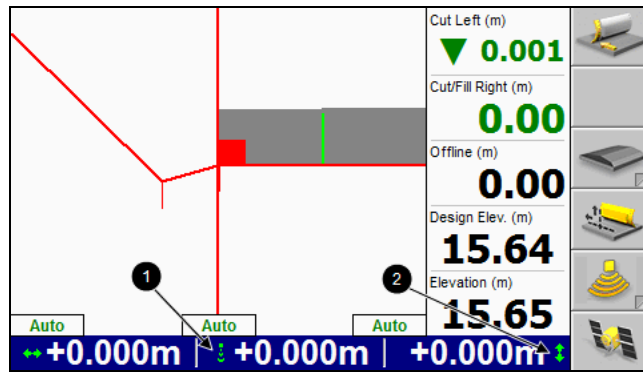

Figure 11.1 A typical 3D plus sonic tracer system

### 11.3.2 3D plus sonic tracer guidance views

The following figure shows an example of the cross-section view guidance screen when the system is gathering 3D plus sonic tracer data:



- ❶ Sonic tracer providing guidance to the left tip
- ❷ Right tip has 3D guidance

Figure 11.2 3D plus sonic tracer cross-section view

# Production Reporting and Map Recording

## In this chapter:

- Production reporting for the office
- Map recording

The GCS900 Grade Control System can record a number of machine and site information statistics, in two different ways. Firstly, production reporting records machine activity statistics and, secondly, map recording records position-oriented site information.

This chapter describes production reporting and map recording.

## 12.1 Production reporting for the office

Production reporting provides a record of machine statistics that are intended for post processing in the site office. As the machine operates, the system generates production reporting (.tag) files which record time, position, elevation and machine-specific productivity statistics.

The system saves the .tag files to the /.Production-Data directory of the system memory. You can transfer the .tag files from system memory to a USB flash drive. You can then manually transfer the files from the USB flash drive to an office PC, or if wireless communications is on, they are transmitted at five minute intervals. If you have subscribed to VisionLink, the files will be transmitted every ten minutes.

At the site office, you can use SiteVision Office software to analyze the .tag files. For more information, refer to the *SiteVision Office Getting Started Guide*.

## 12.2 Map recording



**ATTENTION** — Map recording is intended to provide guidance to the operator, not record detailed terrain and attribute information. A map recording (.map) file stores a “snapshot” of the map on the display, that is, it stores the location of a cell and a numerical value for the color fill. To record detailed terrain (Northing, Easting, and elevation) and attribute data, make sure production reporting is turned on. If you need production reporting data, but the *Map Recording* dialog displays the message “WARNING: Production Reporting is off.” turn production reporting on.

Map recording provides a location-oriented record of machine activity and site information. The various map recording types are described in the following table:

This map recording type ...	Records and displays ...
None	No map recording or display
Terrain	The current ground elevation
Cut/Fill	The cut or fill that is required in order to reach design
Pass count	The number of passes a machine makes over a particular section of ground
Ripper	The ground that has been ripped by the machine's rippers. Ripper map recording is only available on machines with rippers configured
Radio Coverage	The radio signal latency
Record Points	Record the coordinates of the point under the focus point

Map recording is only available when you load a design or a map.



When map recording is enabled, one or more map recording softkeys will appear in the guidance screens.

In some cases it is desirable to record map data only when the elevation of a cell on the current pass is less than the elevation of the same cell on any previous pass. This is called minimum height mapping. Map recording types that can be constrained by minimum height mapping are:

- Terrain map recording
- Cut/Fill map recording

Map recording information is stored in .map files; the .map files are stored in the current design or map folder. Individual map recording files are created for the different map recording types. The system loads the appropriate map recording file, if one exists, when you change the design or map recording type.

The map recording file naming convention is as follows:

<Map recording type><Design or map file name>.map

Use **Reset Map** to archive the selected map recording file and create a new map recording file within the same folder on the USB flash drive. The **Reset Map** softkey  is available from any guidance screen (if configured) and from within the *Mapping/Recording* dialog.

The map recording files use grid cells to store information. For all map recording types the machine blade, bucket, or ripper position is used to determine the cells that are updated with map recording information.

Background shading on the plan view may not coincide exactly with the blade, bucket, or ripper. The extent of the cell, rather than the position of the ends of the cutting edge or ripper, determines where the background is shaded.

When you zoom out, the background shading that appears on the plan view automatically changes to a coarse presentation format. The coarse presentation format shades the whole grid block rather than the individual cells. An average of all cell values within the block determines the color of the block. The block is not shaded if there are not enough cells containing data within the block. The coarse presentation format reduces system loading.

SiteVision Office does not use map recording files. SiteVision Office will recognize the map recording files and allow other files to be downloaded. However, the map recording files are lost when a design is exported back to the USB flash drive from SiteVision Office.

### 12.2.1 Automatic mapping

The system supports the automatic control of map recording. You can control under what conditions maps are recorded by selecting from a number of pre-configured

rules. The availability of a particular rule may depend on machine type and sensor configuration.

### Fixed mapping rules

The following conditions must always be satisfied, and are not configurable:

- Mapping must be turned on, and a design or map loaded and at least one mapping type enabled.
- The system must be receiving high accuracy positions.
- The machine must have moved at least 0.25 m (10 inches) since the last map update.
- The machine must have moved less than 10 m (33 feet) since the last map update.

### Dozer, grader and wheel tractor-scraper mapping rules

The following mapping types can be subject to automatic control on earthmoving machines:

- Pass count
- Terrain
- Radio
- Cut/Fill

The following conditions can be combined to control mapping on earthmoving machines:

- Minimum height – this condition is satisfied when the elevation of a cell on the current pass is less than the elevation of the same cell on any previous pass.
- Blade tip – this condition is satisfied when a condition, selected from the following list, is satisfied:
  - Driving forward – this condition is satisfied when the machine is moving forwards
  - Automatics on – this condition is satisfied when the automatic controls are turned on
  - Auto+forward – this condition is satisfied when the machine is moving forwards and the automatic controls are turned on
  - Blade On Ground sensor – this condition is satisfied when the "Blade On Ground" sensor group estimates that the machine's cutting edge is at, or below, ground level and the machine is moving dirt
  - Always – this condition is always deemed to be satisfied

### Excavator mapping rules

The following mapping types can be subject to automatic control on excavators:

- Pass count
- Terrain
- Radio
- Cut/Fill

The following conditions can be combined to control mapping on excavators:

- Minimum height – this condition is satisfied when the elevation of a cell on the current pass is less than the elevation of the same cell on any previous pass.
- Bucket tip – this condition is satisfied when a condition, selected from the following list, is satisfied:
  - Arm retracting – this condition is satisfied when the arm is retracting
  - Always – this condition is always deemed to be satisfied
  - Never – this condition is never satisfied

#### 12.2.2 Terrain map recording

Terrain map recording shades the plan view to show the ground that has been covered by the machine.

Terrain map recording uses  $1 \times 1$  m grid cells. A cell is marked as covered when the cutting edge passes over the cell. A cell that is marked as covered is shaded gray on the plan view as shown in the following figure.

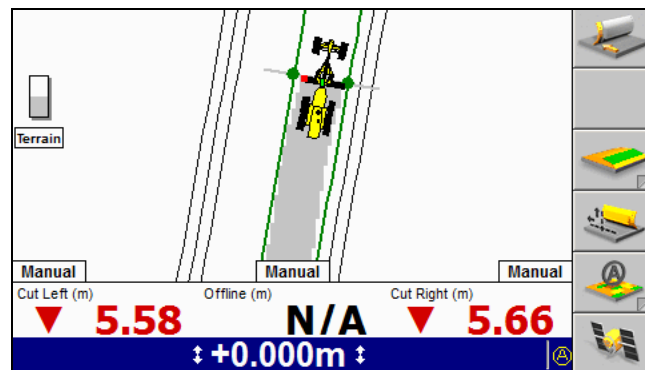

For constraints that can be applied to terrain mapping, see [12.2.1 Automatic mapping](#).

### 12.2.3 Cut/Fill map recording

Cut/Fill map recording provides a plan view background that is color coded according to the quantities of cut and the quantities of fill required in the areas passed over by the machine.

You can only use Cut/Fill map recording with a 3D design loaded. The elevation of the cutting edge ends is determined and the elevation along the cutting edge is interpolated. The difference between the cutting edge elevation and the design elevation is stored for the cells below the cutting edge as the machine passes over the ground. An example is shown in the following figure.

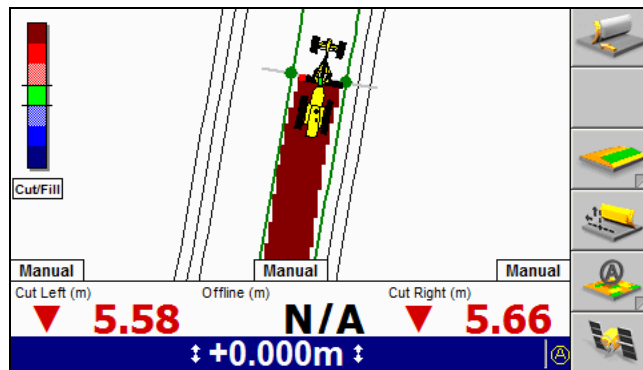

Cut/Fill map recording uses  $1 \times 1$  m grid cells. If you lift the blade off the ground while Cut/Fill map recording is on, then invalid Cut/Fill values are recorded in the cells, and the Cut/Fill color coding is invalid.

You can apply vertical offsets and reference surfaces to the design at any time. The elevation differences that are stored in the cells are adjusted for the offsets, and the Cut/Fill background color coding is updated.

Reference surfaces and vertical offsets are not automatically loaded with a design. To ensure that Cut/Fill color coding is consistent make sure that vertical offsets and reference surface configurations are consistent with the original configuration after reloading a design.

If you change any design elevations the Cut/Fill map recording must be reset. Cut/Fill map recording data recorded before the change will not be consistent with the changed design.

If you create a Cut/Fill map on a sloping design or a level design and then edit the design, the previously recorded Cut/Fill map will still apply to the old design.

If you are using lane guidance, no updates will occur when a lane is changed. The Cut/Fill map recording must be reset. If the cutting edge passes over the same area again, the Cut/Fill color coding is updated with respect to the currently selected lane.

The vertical tolerance used for the lightbar scales is used to determine the Cut/Fill color coding for the background on the plan view. The following table shows how Cut/Fill map recording is color coded:

Color	Cut/Fill
Dark Red	Cut > 4 x Vertical Tolerance
Red	Cut > 2 x Vertical Tolerance Cut < 4 x Vertical Tolerance
Light Red	Cut > 1 x Vertical Tolerance Cut < 2 x Vertical Tolerance
Green	Cut/Fill is within Vertical Tolerance
Light Blue	Fill > 1 x Vertical Tolerance Fill < 2 x Vertical Tolerance
Blue	Fill > 2 x Vertical Tolerance Fill < 4 x Vertical Tolerance
Dark Blue	Fill > 4 x Vertical Tolerance

For constraints that can be applied to Cut/Fill mapping, see [12.2.1 Automatic mapping](#).

### 12.2.4 Pass count map recording

Pass count map recording shades the plan view to show the number of passes a machine has made over an area of ground.

Pass count map recording uses 1 × 1 m grid cells. The pass number for a cell is incremented each time the cutting edge passes over the cell. The number of passes over a cell determines the color of the cell on the plan view.

When you load a design, any data from an existing pass count map file appears on the plan view. A color key indicating color coding for the *Required passes* also appears in the plan view, as shown in the following figure.

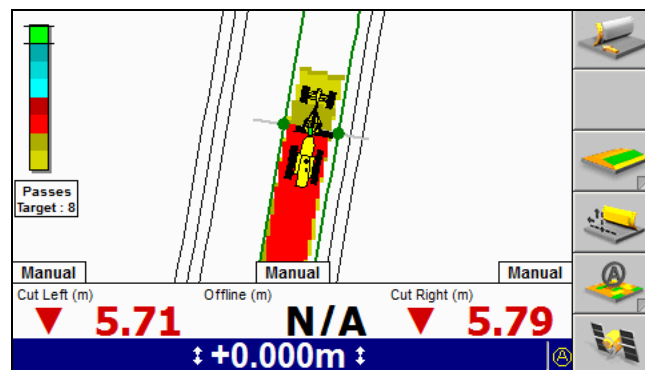

For constraints that can be applied to pass count mapping, see [12.2.1 Automatic mapping](#).

### 12.2.5 Ripper map recording

Ripper map recording provides a plan view background of the ground that has been ripped by the machine rippers.

Automatic mapping is not available for ripper map recording, and ripper map recording must be controlled manually.

You must make sure that the distance from the machine blade to the ripper is correctly specified in the machine dimensions.

Ripper map recording uses  $1 \times 1$  m grid cells. A cell is marked as ripped when the machine's ripper passes over the cell. The cell is shaded gray on the plan view, as shown in the following figure.

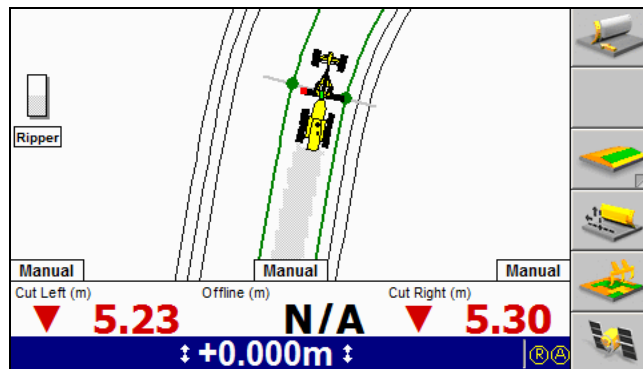

### 12.2.6 Radio coverage map recording

Radio coverage map recording is only available for GNSS-based 3D systems. Radio coverage map recording shades the plan view to show the latency of the radio reception.

Radio coverage recording uses  $2 \times 2$  m grid cells. The radio latency is stored for the cell as the machine cutting edge passes over a cell, as shown in the following figure.

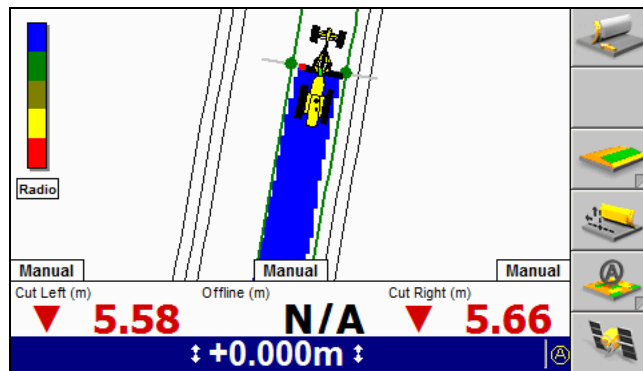

The following table shows how radio coverage recording is color coded:

Color	Radio signal latency
Blue	< 2 seconds
Dark Green	> 2 seconds and < 3 seconds
Dark Yellow	> 3 seconds and < 4 seconds
Yellow	> 4 seconds and < 5 seconds
Red	> 5 seconds

Unlike other map recording types, radio coverage recording continues when *Low Accuracy* is indicated for GNSS positioning.

For constraints that can be applied to radio coverage mapping, see [12.2.1 Automatic mapping](#).

### 12.2.7 Record points

This release of the system supports a mapping feature that allows the user to record the 3D location of a point identified by the position of the blade or bucket.

The point data is recorded in a \*.csv file of the form “Points\_<machine name>\_<increment>.csv”. CSV files can be opened in a text editor, such as Microsoft® Notepad, or in applications that recognize the format, such as Trimble Business Center – HCE. The files are stored in the folder for the loaded design or the currently selected map. If no design is loaded or if no map is selected, point recording can be enabled, however it cannot be used.

This feature is available on 3D excavator and fine grading systems.

**Note** – 3D excavator systems also support point recording via a remote switch.

An example is shown in the following figure.

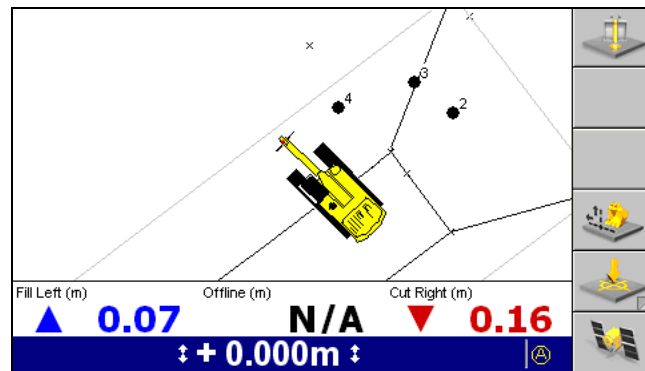

### 12.2.8 Reset map

Pressing the **Reset Map** softkey  closes the selected map recording file and creates a new map recording file in the same directory.

If you reset the map recording file that is currently selected for display on the plan view, then the plan view is cleared of all shading. The color key, if any, remains visible.

The renaming convention is:

- <Map recording type><Design file name>nnn.map, where n increments for each newly renamed file.

The system cannot display a renamed map recording file unless the renamed file is manually renamed in the office to remove the “nnn”.



# Automatic Controls

## In this chapter:

- Automatic controls overview
- Automatic control states
- Optimizing automatic controls
- Using automatic controls

This chapter introduces the use of automatic controls with the motor grader, dozer and scraper machine types.

## 13.1 Automatic controls overview



**WARNING** — Do not operate this system unless you are fully trained on this equipment and end-use equipment.

The cutting edge of the machine may move without warning when automatic controls are on. These sudden movements could cause injury to anyone near the cutting edge, or damage to the machine. Always put the system in Manual and engage the machine's park brake before you leave the machine, or when somebody is working near the cutting edge.

When the blade is not in operation, leaving it in the air could cause injury to you and others, or damage to the vehicle. Always place the blade on the ground when it is not in use.

As the system equipment may extend beyond the extents of the blade, operating the machine close to people and objects could cause injury to them or damage to the vehicle or system equipment. Maintain adequate clearance from people and objects when operating the vehicle.

The blade may move abruptly during hydraulic valve calibration. To avoid injury, make sure the machine's park brake is engaged, and that the calibrations are supervised by an operator in the machine cab. Maintain adequate clearance from people and objects during the hydraulic valve calibration.

---

Most automatic control systems are available in two options:

- Automatic lift only (vertical control)
- Automatic lift and sideshift (vertical and horizontal control)

Most systems that use automatic controls incorporate the following components to provide automatic control of the cutting edge:

- A valve controller that processes valve drive commands generated by the system
- Blade control valves — blade lift and sideshift (if configured). The valves are automatically driven by the valve controller to move the blade onto the current design surface
- Remote switches, mounted on a motor grader's blade lift levers, or in another suitable location in other machines, to:
  - Switch the blade lift control between automatic mode and manual mode
  - Increase or decrease the vertical offset or target slope
  - Switch the sideshift control between automatic mode and manual mode

## 13.2 Automatic control states

When you configure automatic controls, the automatic control status indicator appears in the lower left and right sides of the screen to show the current state of the controls.

If an automatic control status indicator does not display, then:

- The automatic controls are not configured
- A required device is not responding
- A guidance method that provides guidance to only one end of the blade has been selected, for example cross slope

Automatic controls can be in one of the following states:

- Manual
- Auto
- Inactive-Auto
- Unknown

Any of the four auto states usually provide guidance information on the control box and on the lightbars.

*Note* – The only exception is when a laser receiver loses laser strikes from the laser transmitter and the system goes into Inactive-Auto mode. No guidance will be given if this occurs.

When the automatic controls are active, you can use the horizontal guidance information to manually steer the machine and the vertical guidance to monitor the performance of the automatic controls.

### 13.2.1 Manual

When the Auto/Manual switch is set to Manual, automatic controls are not in use. In Manual state, the system operates as an Indicate system.

The following figure shows the system in Manual state.

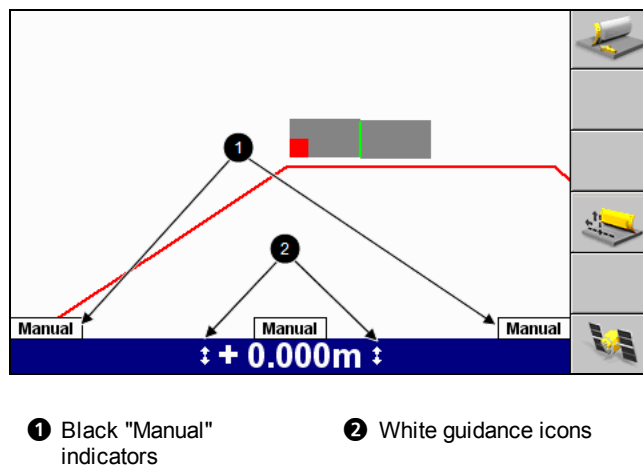

Figure 13.1 Manual state guidance screen

### 13.2.2 Auto

When an Auto/Manual switch is set to Auto, and the status indicator displays *Auto* in **green**, the automatic controls are enabled.

For motor graders, you can put each end of the blade under automatic controls, independently. For conventional guidance methods that report guidance information for one end of the blade only (for example, cross slope guidance), only the end of the blade receiving guidance is controlled automatically.

The following figure shows a motor grader system with both ends of the blade under automatic control.

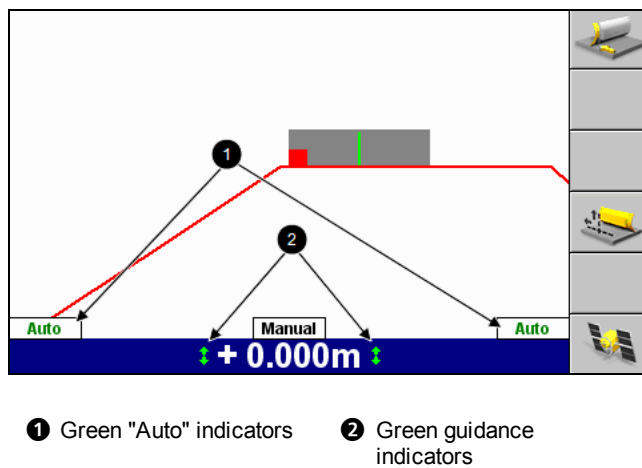

Figure 13.2 Auto state guidance screen – both ends of the cutting edge under automatic control

The following figure shows the state of the status indicators when only one end of the blade is under automatic control.

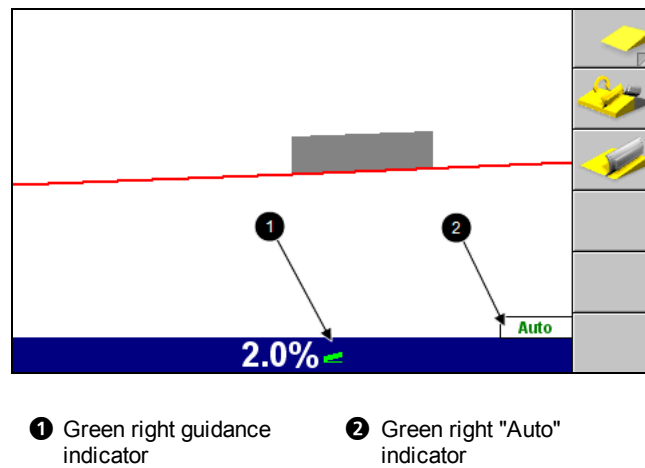

Figure 13.3 Single end automatic control guidance screen

**Note** – If you use the cross slope guidance or one-point lift guidance methods, then only one end of the cutting edge receives guidance. In the example shown in [Figure 13.3](#), only the right end of the cutting edge is receiving guidance, so only the right end of the blade can be under automatic control.

The following figure shows a motor grader system receiving 3D guidance. The left end of the blade is under automatic control and the right end under manual control.

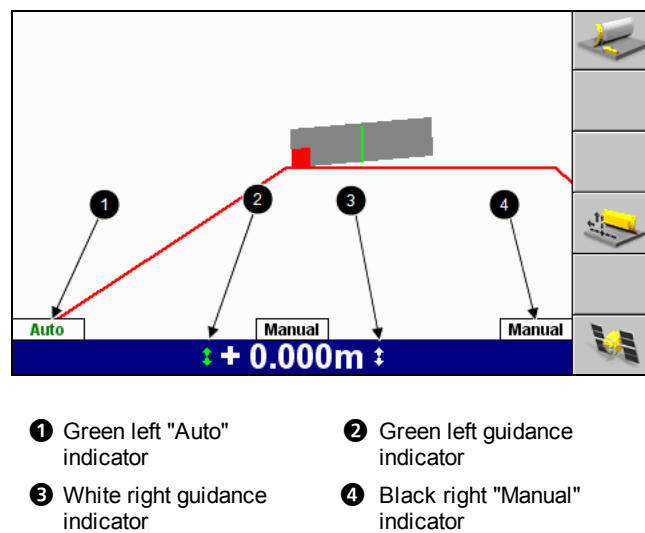

Figure 13.4 Mixed state guidance screen

**Note** – If you use a 3D guidance method, then both ends of the blade receive guidance information. In the example shown in [Figure 13.4](#), if automatic controls are enabled for the end of the blade receiving focus (left end of the blade) only, then that end is driven until the elevation of that tip matches the elevation of the design. The right hand end must be manually controlled for cross slope.

The following figure shows the system with sidseshift under automatic control.

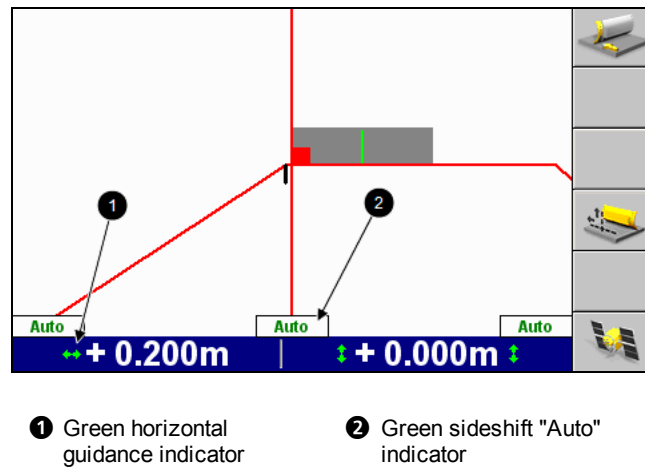

Figure 13.5 Sidseshift auto state guidance screen

While automatic controls are on, the system suspends them for up to sixty seconds when:

- the machine moves outside the design boundary
- the cutting edge is outside the automatic controls range
- the cutting edge moves outside the automatic controls range

In these cases, the **Off Design** or **Out of Sidseshift Range** flashing error messages display, and automatic control is suspended, but the status indicator still displays *Auto* in green.

If the condition is corrected within sixty seconds, the flashing error message no longer displays, and automatic control is re-established.

If the condition is not corrected within sixty seconds, the flashing error messages continue, the status indicator flashes *Auto* in red, and the automatic controls go into the Inactive-Auto state.

This feature allows you to turn around at the end of a run with the blade raised, and begin a new run without having to use the Auto/Manual switches.

### 13.2.3 Inactive-Auto

When the Auto/Manual switch is set to Auto, and the status indicator flashes *Auto* in **red**, the automatic controls are in the Inactive-Auto state.

In the Inactive-Auto state, with the exception of a laser, the system disables the automatic controls and operates as an Indicate system. The control box and lightbars still provide horizontal and vertical guidance. The Inactive-Auto state is similar to the Manual state, except that the Auto/Manual switch is set to Auto.

**Note** – If a laser receiver loses strikes from the laser transmitter the system goes into Inactive-Auto mode. No guidance will be given and you will get the flashing Hi-Low indication.

The following figure shows the system operating as an Indicate system.

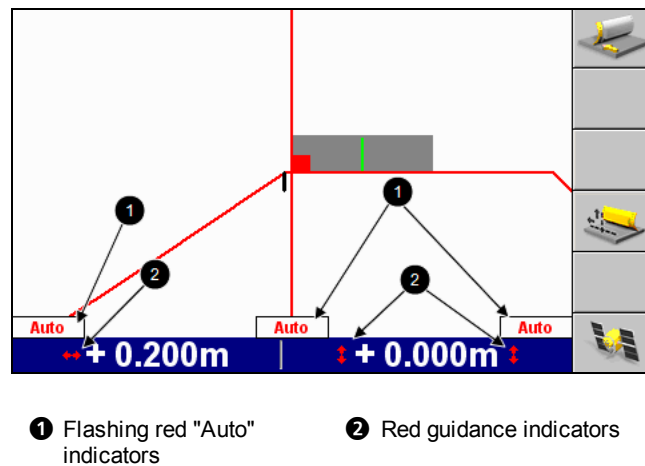

Figure 13.6 Inactive-Auto caused by accessing a guidance setup dialog

Controls enter the Inactive-Auto state when:

- You access any guidance setup, configuration, or installation dialog.
- No design is loaded.
- The machine is off the design when automatic controls are turned on.
- The machine is off the design for more than 60 seconds.
- A sonic tracer is out of range of the reference surface for more than 60 seconds.

During the period that the sonic tracer is out of range of the reference surface and before the system goes into the Inactive-Auto state, the systems suspends lift control. However, if cross-slope control is turned on for the other end of the blade, then cross-slope control continues for 60 seconds. If you put the end of the blade with the sonic tracer into Manual within those 60 seconds, then cross-slope control for the other end of the blade will continue indefinitely.

- The automatic valves are not calibrated.
- The automatic valves are not driven (the valves have been inactive) for 60 seconds or longer.
- The system can no longer detect a device.
- A device stops working.
- The control box starts and the Auto/Manual switch is set to Auto.

- The control box shuts down.
- You receive low accuracy GNSS positions continuously for more than 60 seconds.

During the period you are receiving low accuracy GNSS positions and before the system goes into the Inactive-Auto state, the system suspends automatic controls.

- The UTS loses lock on the target.

When turned on, the beeper will sound for these conditions.

To change from the Inactive-Auto state to the Auto state:

1. Set the Auto/Manual switch to Manual.
2. If necessary, correct any safety conditions or startup errors.
3. Set the Auto/Manual switch back to Auto.

#### 13.2.4 Unknown

When the control box receives no information about the state of the automatic controls, the automatic controls change to the Unknown state. When this occurs, check the valve control module.

### 13.3 Optimizing automatic controls

There are four options for optimizing automatic controls:

- Valve speed
- Valve tune
- Stability tuning
- Vertical offset increment

#### 13.3.1 Valve speed

The correct automatic control valve speed for the job depends on the:

- type of material that the machine is moving
- accuracy required
- speed of the machine

For example, if you are using coarse material to lay the base of a road, it may be acceptable to trade off a small decrease in accuracy against faster grading speeds.



The system enables you to adjust the speed of the valves that automatically control the blade. If the valve speeds are set too high, the system reacts too quickly. This can cause the system to become unstable and the blade to overshoot and then return to grade, as well as causing unnecessary work for the hydraulic machine components. If the valve speeds are set too low, the system reacts too slowly, and the blade takes too long to return to an on-grade position. Both situations cause inaccuracies in the final surface.

For more information, refer to the *GCS900 Grade Control System Operator's Manual* for your machine type.

### 13.3.2 Valve tune

You can use valve tuning to improve the performance of the automatic controls when driving the valves by small amounts only.

For more information, refer to the *GCS900 Grade Control System Operator's Manual* for your machine type.

### 13.3.3 Vertical offset increment

You can use the vertical offset switch to move the cutting edge up or down by a set amount at the beginning of each grading run, so that the working surface approaches the design surface, over successive runs.

The system enables you to adjust the amount that each movement of the vertical offset switch increases or decreases the vertical offset. The correct increment/decrement amount depends on the type of material that the machine is moving and the current working conditions.

The site supervisor sets the vertical offset increment. You should contact your site supervisor if you think the vertical offset increment is too coarse or too fine for the type of work you are doing.

## 13.4 Using automatic controls

Before you use automatic controls, make sure that you do the following:

- Configure the automatic controls.
- Complete the startup checks.
- Pass the safety checks.
- Set the Auto/Manual switch to Auto.



**Tip** – It is recommended that you set the Auto/Manual switch to Manual until all startup checks are completed, you are on design and you are ready to start using automatic controls.

The following steps outline a typical sequence of actions to prepare the system for a job that uses automatic controls:

1. Set a working surface for vertical guidance.
2. If available, set an alignment for horizontal guidance.
3. With the automatic controls set to Manual, line up the machine for the pass and move the blade so that it will cut or fill a reasonable amount of material. Set the vertical offset so that the cut/fill indicator on the lightbars reads approximately 0 (zero).
4. Start to move smoothly along the pass.
5. Set the Auto/Manual switch(es) to Auto. If you are operating a motor grader, avoid rotating and manually sideshifting the blade if possible.
6. At the end of the pass, change the Auto/Manual switch(es) to Manual and lift the blade.
7. Repeat steps 3 through 6 until the vertical offset is reduced to 0 (zero) and the blade is on the working surface.

*Note – If the blade is too full, use the vertical offset increment switch to reduce the amount of material being moved on the pass. You can do this at any stage.*

# Index

- .
- .cal file 62
- .cfg file 62
- 3**
- 3D guidance
  - avoidance zone warnings 154
  - avoidance zones 153
  - background linework 158
  - cross-section view 182
  - cut adjustment 189
  - definition 20
  - design avoidance zones 154
  - design boundary 158
  - design files 108
  - design surfaces 108
  - focus, definition 152
  - GNSS accuracy mode 58
  - guidance plane 152
  - horizontal lightbar information 191
  - horizontal offsets 203
  - layered lifts 162
  - machine orientation and pitch 205
  - no avoidance zone guidance 156
  - offset, vertical 112
  - on-screen linework 157
  - one-point center 181
  - one-point focus 184
  - overcut protection 189
  - overview 152
  - perpendicular lifts 170
  - plan view 183
  - reference surfaces 161
  - road alignments 159
  - site avoidance zones 154
  - site map 157
  - text items
    - Avoid. Dist 154
    - Cut Adjust 190
    - Cut/Fill 181
    - Offline 192
  - two-points tips 187
  - vertical guidance points, definition 152
  - vertical lifts 172
  - vertical lightbar information 181

- working surfaces 160
- 3D lines designs
  - alignments 199
  - horizontal guidance, about 199

## A

- AS450 angle sensor
  - about 66
  - usable range 67
- AS456 angle sensor
  - about 66
  - usable range 67
- automatic controls
  - Auto 224
  - Inactive-Auto 226
  - Manual 223
  - optimizing 228
  - overview 222
  - Sideshift 225
  - states 223
  - status indicator 222
  - suspended Auto 226
  - Unknown 228
  - valve speed 228
  - valve tune 229
  - valves 222
  - vertical offset switch increment 229
- automatic slope swap 135
- AutoPan 47
- Autoselect road alignment 194
- avoidance zones
  - 3D guidance 153
  - design 154
  - no guidance 156
  - site 154
  - warnings 154

## B

- background linework 158
- beeper
  - avoidance zone warning 154
- benching 107
- blade slope guidance
  - cross-section view 120
  - definition 118
  - guidance information 120
  - lightbar information 120
  - sensors 119

**C**

- CAN bus valve modules 101
- Caterpillar A4M1 valve module 101
- Caterpillar G-Series ARO valve module 101
- Caterpillar PSC 76
- cellular modems
  - about 83
  - SNM940 83, 85
  - third-party 84
- control box settings 51
- conventional guidance
  - automatic slope swap 135
  - benching 107
  - blade slope 118
  - cross slope 125
  - definition 20
  - design surfaces 106
  - independent lift 130
  - lift 121
  - lift plus blade slope 123
  - lift plus cross slope 127
  - linked lift 132
  - offsets, vertical and slope 112
  - overview 118
  - sensor swap 135
- cross-section view 42
- cross slope guidance
  - cross-section view 126
  - definition 125
  - guidance information 126
  - lightbar information 127
  - sensors 125
- cut adjustment 189
- Cut/Fill map recording 216

**D**

- dark background mode 47
- daylight point markers 195
- daylight points 195
- Depth Dual Slope guidance 141
- Depth guidance 138
- Depth Slope guidance 140
- design avoidance zones 154
- design boundary 158
- design files
  - 3D lines 111
  - about 108
  - background linework 158
  - design boundary 158

- design surfaces 108
- grid 109
- level surfaces, about 109
- on-screen linework 157
- operator created 109
- road 109
- road alignments 159
- site map 157
- sloping surfaces 110
- SVD 109
- TIN 109

Design softkey 153

design surfaces

- 3D 108
- 3D design files 108
- about 106
- conventional 106

diagnostic text file 51

Direction Lock 153

dynamic layered lifts

- dual slope 168
- single slope 166

**E**

- elevation from a benchmark
  - laser referencing 148
  - Touch-Point 148
- elevation offset 112
- EM400 92
- errors
  - Low Accuracy - GNSS 60
  - Off Design 226
  - Out of Auto Range 226
- excavator 2D guidance
  - Depth 138
  - Depth Dual Slope 141
  - Depth Slope 140
  - elevation reference
    - from a laser plane 147
  - introduction 138
  - Measure mode 146
  - methods 138
  - Profile 143
  - sensors 138

**F**

- file transfer to/from office 50
- flashing warning messages 48
- focus point 152
- full screen warning messages 48

**G**

- GNSS accuracy mode
  - about 58
  - lightbar behavior 60
  - text items 58
- GNSS receiver
  - GNSS accuracy mode 58
  - usable range 55
- guidance
  - 3D 20
  - 3D, one-point 21
  - 3D, two-points 21
  - blade slope 21
  - conventional 20
  - conventional guidance overview 118
  - cross slope 21
  - levels 20
  - lift plus blade slope 21
  - lift plus cross slope 21
  - one-point lift 21
- guidance methods
  - blade slope 118
  - cross slope 125
  - lift plus blade slope 123
  - lift plus cross slope 127
  - one-point center 181
  - one-point focus 184
  - two-points tips 187
- guidance plane 152
- guidance screens
  - about 40
  - cross-section view 43
  - dark background mode 47
  - level view 45
  - moving between 40
  - panning 47
  - plan view 40
  - profile view 43
  - split view 44
  - text views 45
  - zooming 46

**H**

- horizontal guidance
  - 3D lines 199
  - alignments 191
  - background plan linework 202
  - daylight points 195
  - design boundaries 202

- dynamic layered lift alignments 195
- horizontal offsets 203
- layered lift alignments 195
- plan lines 202
- road alignments 192
- side slope alignments 199
- site map linework 202
- sloping surface alignments 200
- text items 196
- horizontal offsets 203

**I**

- IBSS 56
- independent lift
  - definition 130
  - sensors 130
  - vertical guidance points 130
- independent lift-lift
  - cross-section view 131
  - guidance information 131
- internet base station service 56

**J**

- John Deere EHC valve module 101

**K**

- keys
  - Next 40
  - Zoom In (+) 46
  - Zoom Out (-) 46
- Komatsu valve module 101

**L**

- laser referencing 148
- layered lifts
  - about 162
  - alignments 195
  - dynamic 162
  - standard 163
- LB400 external lightbar
  - specifications 94
- LC450 angle sensor
  - about 66
  - usable range 67
- level surfaces 109
- level view 45
- lift
  - definition 121
  - sensors 121

- vertical guidance points 121
- lift guidance 121
- lift plus blade slope guidance
  - cross-section view 124
  - definition 123
  - guidance information 124
  - lightbar information 125
  - sensors 123
  - vertical guidance points 123
- lift plus cross slope guidance
  - cross-section view 129
  - definition 127
  - guidance information 129
  - sensors 128
  - vertical guidance points 128
- lightbar tolerances 95
- lightbars
  - brightness 96
  - excavator 97
  - guidance information 95
  - low accuracy GNSS 60
  - motor grader, bulldozer and scraper 96
  - using 94
  - vertical and horizontal tolerance 95
- linked lift
  - cross-section view 134
  - definition 132
  - guidance information 134
  - sensors 133
  - vertical guidance points 133

## M

- machine configuration files 50
- map recording 212
  - Cut/Fill 216
  - radio coverage 218
  - record points 219
  - reset map 220
  - terrain 215
- Measure mode, excavator 2D guidance 146
- messages
  - flashing warnings 48
  - full screen warnings 48
  - office 49
- moving between guidance screens 40

## O

- office messages 49
- offsets 112
- on-screen linework 157

- one-point center 3D guidance
  - cross-section view 182
  - guidance information 182
  - plan view 183
  - sensors 179
  - vertical guidance points 181
- one-point focus 3D guidance
  - cross-section view 185-186
  - guidance information 185-186
  - sensors 179
  - vertical guidance points 184-185
- one-point lift
  - cross-section view 122
  - guidance information 122
- overcut protection 189

## P

- perpendicular lifts 170
- plan line alignments 202
- plan lines 202
- plan view 40
- PM400 power module 93
- point-and-direction method 110
- power module 93
- production reporting 212
- Profile guidance 143
- profile view 43

## R

- radio coverage map recording 218
- record points map recording 219
- reference surfaces 161
- release notes 16
- reset map 220
- ripper map recording 218
- road alignments 159
- road design alignments
  - about 192
  - Autoselect 194
- road designs
  - alignments 192
  - layered lift alignments 195
  - side slope alignments 199
- RS400 rotation sensor
  - about 72
  - usable range 73

## S

- screen shots 51

- sensor swap 135
  - sensors
    - AS450 angle sensor 66
    - AS456 angle sensor 66
    - blade slope 73
    - Caterpillar PSC 76
    - cross slope group 73
    - GNSS receiver 55
    - guidance levels 20
    - LC450 laser catcher 66
    - LR410 laser receiver 70
    - rotation 73
    - RS400 rotation sensor 72
    - SR300 survey laser receiver 76
    - ST400 sonic tracer 71
    - Trimble universal total station 64
  - side slope alignments 199
  - site avoidance zones 154
  - site design 106
  - site map 157
  - Sky Plot 59
  - slope offset 112
  - slope swap, automatic 135
  - sloping surface designs
    - about 110
    - alignments 200
    - point-and-direction method 110
    - two-points method 111
  - SNM940 data communications module
    - about 83, 85
    - specifications 83, 85
  - softkeys
    - Design 153
    - Zoom All 46
    - Zoom Machine 47
  - split screen 44
  - SR300 survey laser receiver
    - operating limits 76
  - ST400 sonic tracer
    - usable range 71
  - status indicator, controls 222
  - system components 20
    - electric mast 92
    - power module 93
    - system harness 20
    - valve module 101
  - system state snapshot 51
- T**
- terrain map recording 215
- text items**
- Avoid. Dist. 154
  - Cut Adjust 190
  - Cut/Fill 181
  - GNSS Acc. Mode 58
  - H. GNSS Err. 58
  - Offline 192
  - Offline DL 197
  - Offline DR 197
  - Offline L 196
  - Offline R 196
  - V. GNSS Err. 58
- text views** 45
- tolerances** 95
- Touch-Point** 148
- troubleshooting**
- diagnostic text file 51
  - screen shots 51
  - zsnap files 51
- two-points method** 111
- two-points tips 3D guidance**
- cross-section view 188
  - default vertical guidance point position 188
  - guidance information 188
  - sensors 179
  - vertical guidance points 187

**U****USB**

- design surfaces 108
  - display settings file 51
  - machine settings file 50
- UTS, Trimble universal total station** 64
- startup 65
  - usable range 65

**V**

- valve speed 228
  - valve tune 229
- vertical guidance points**
- 3D 152
  - guidance plane 152
  - independent lift 130
  - lift 121
  - lift plus blade slope 123
  - lift plus cross slope 128
  - linked lift 133
  - one-point center 3D 181
  - one-point focus 3D 184-185
  - two-points tips 3D 187

- vertical lifts
  - about 172
- vertical offset 112
- vertical offset switch
  - set increment/decrement amount 229
- virtual reference station 56
- VM410 valve module 101
  - specifications 101
- VM415 valve module 101
  - specifications 102
- VM420 valve module 101
  - specifications 103
- VM430 valve module 101
  - specifications 104
- VRS, virtual reference station 56

## W

- warnings
  - avoidance zone distance 154
  - avoidance zone guidance 154
- Wi-Fi networks 84
- wireless communications with office 50
- working surfaces
  - about 160
  - layered lifts 162
  - perpendicular lifts 170
  - reference surfaces 161
  - vertical lifts 172
- World Wide Web site 17

## Z

- zoom
  - all 46
  - in 46
  - machine 47
  - out 46
- zsnap files 51